



Education

KwaZulu-Natal Department of Education
REPUBLIC OF SOUTH AFRICA

MATHEMATICS

COMMON TEST

SEPTEMBER 2016

**NATIONAL
SENIOR CERTIFICATE**

GRADE 11

MARKS: 75

TIME: 1½ hours

N.B: This question paper consists of 7 pages.

INSTRUCTIONS AND INFORMATION

Read the following instructions carefully before answering the questions.

1. This question paper consists of **FIVE** questions.
2. Answer **ALL** the questions.
3. Clearly show **ALL** calculations and diagrams that you have used in determining your answer.
4. You may use an approved scientific calculator (non-programmable and non-graphical).
5. If necessary round off answers to **TWO** decimal places, unless stated otherwise.
6. Answers only will not be awarded full marks.
7. Diagrams are not necessarily drawn to scale.
8. Number the answers correctly according to the numbering system used in this question paper.
9. Write neatly and legibly.

QUESTION 1

- 1.1 A travel agent did a survey amongst his clients as to which type of holiday they prefer. The table below shows the results of this survey.

	Game reserve	Sea	Drakensberg	Total
Male	250	70	a	500
Female	150	b	160	c
Total	d	170	e	910

- 1.1.1 Write down the values of a, b, c, d and e. (2)

- 1.1.2 If a client is selected at random, what is the probability that this client

- (a) Will prefer visiting a game reserve? (1)
 (b) Will be a female? (1)
 (c) Will be a female and prefer visiting a game reserve? (1)
 (d) Will be a female or prefer visiting a game reserve? (2)

- 1.1.3 Consider the following two events:

Event A: a client is a female

Event B: a client prefers visiting a game reserve when going on holiday.

Are events A and B independent? Motivate your answer with the necessary calculations. (3)

- 1.2 Figures obtained from a city's police department indicate that of all the vehicles stolen, 70% were stolen by syndicates (gangs) to be sold off, and 30% were stolen by individual persons for their own use.

Of the vehicles stolen by syndicates:

- 10% were recovered (found back) within 24 hours;
- 30% were recovered after 24 hours; and
- 60% were never recovered.

Of the vehicles stolen by individual persons:

- 30% were recovered within 24 hours;
- 40% were recovered after 24 hours; and
- 30% were never recovered.

- 1.2.1 Draw a tree diagram to represent the above information. (3)

- 1.2.2 Calculate the probability that if a vehicle was stolen in this city, it would be stolen by a syndicate and recovered within 24 hours. (2)

- 1.2.3 Calculate the probability that a vehicle stolen in this city will not be recovered. (3)

[18]

QUESTION 2

A frustum is the portion of a cone which remains after a smaller cone has been cut off its upper part.

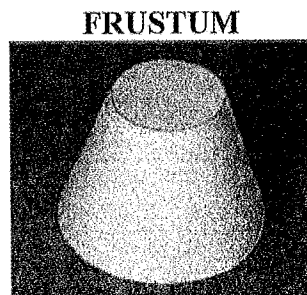
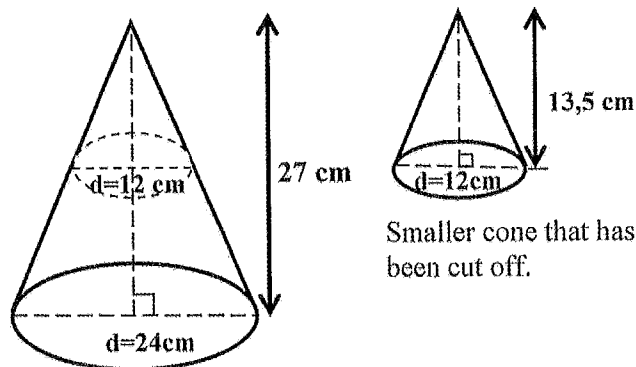

The height of the small cone is 13,5 cm and the height of the large cone is 27cm.
The diameter of the base of the large cone is 24cm and the diameter of the base of the small cone is 12cm.

2.1 Find the volume of the frustum, giving your answer in terms of π .

(4)

2.2 The frustum has the same volume as a certain sphere.
Calculate the radius of this sphere.

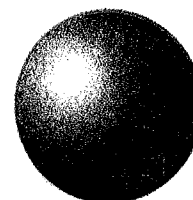

List of formulas to choose from when answering Question 2:

$$V = \frac{4}{3}\pi r^3$$

$$V = \pi r^2 h$$

$$V = \frac{1}{3}\pi r^2 h$$

(3)

[7]

QUESTION 3

3.1 In the diagram $A(-15; p)$ is a point such that $OA = 17$ and $\widehat{DOA} = \theta$, where θ is a reflex angle.

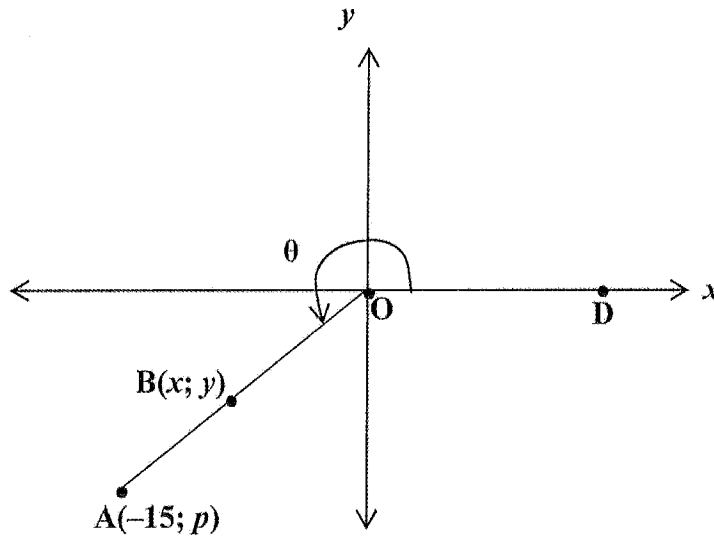

3.1.1 Calculate the value of p . (2)

3.1.2 Determine the value of each of the following without the use of a calculator:

(a) $\cos \theta$ (1)

(b) $\tan (180^\circ - \theta)$ (2)

(c) $\sin (\theta - 360^\circ) \cdot \cos (90^\circ - \theta)$ (3)

3.1.3 **B** is a point on **OA**, such that $OB = 10$. Calculate the values of x and y without calculating the size of angle θ . (4)

3.2 Simplify the following and express your answer as a single trigonometric term.

$$\frac{\cos (-x) \cdot \tan 225^\circ}{\sin 90^\circ - \sin x} + \tan (360^\circ - x)$$
 (7)

3.3 Prove the following identity:

$$\frac{2 \sin^2 x}{2 \tan x - 2 \sin x \cos x} = \frac{\cos x}{\sin x}$$
 (4)

3.4 Determine the general solution for x if:

$$\sin (2x + 15^\circ) = \cos (\frac{1}{2}x - 15^\circ)$$
 (5)

[28]

QUESTION 4

The following sketch represents the graphs of:

$$f(x) = a \cos(x + b) \quad \text{and}$$

$$g(x) = c \sin x \quad \text{for } x \in [-180^\circ; 180^\circ]$$

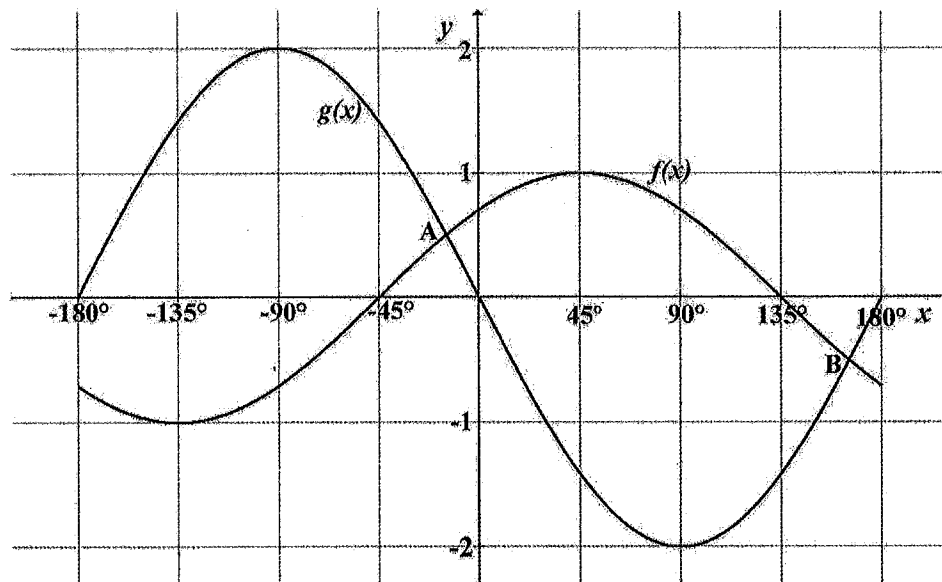

- 4.1 From the sketch above write down the values of a , b and c . (3)
- 4.2 A $(-14, 64^\circ; p)$ and B $(q; -0,51)$ are the coordinates of the points of intersection of f and g . Write down, rounded off to 2 decimal places, the values of:
- 4.2.1 p (1)
- 4.2.2 q (1)
- 4.3 For which values of x will $f(x) \cdot g(x) \geq 0$? (2)
- 4.4 If the graph of f is shifted 45° to the left, write down the equation of the new graph. (1)
- [8]

QUESTION 5

- 5.1 In the figure below, $AB = 107 \text{ mm}$, $BC = 68 \text{ mm}$ and $\hat{A}BC = 79^\circ$. $AC \perp DC$.
 $\hat{D}AC = 22^\circ$.

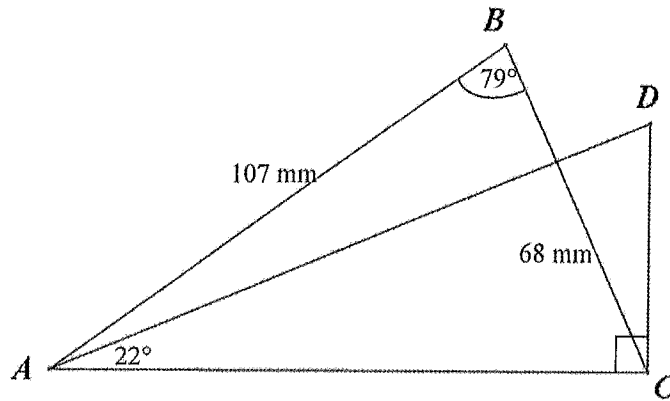

5.1.1 Calculate the length of AC. (3)

5.1.2 Calculate the length of DC. (2)

5.2

5.2.1 Complete: Area of $\Delta ABC = \frac{1}{2} ab \dots\dots\dots$ (1)

5.2.2 In the figure below $AB = AD$ with $DC = \frac{1}{2} BD$ and $DC = r$.
It is also given that $\hat{A}BD = \alpha$ and $\sin 2\alpha = 2 \sin \alpha \cos \alpha$.

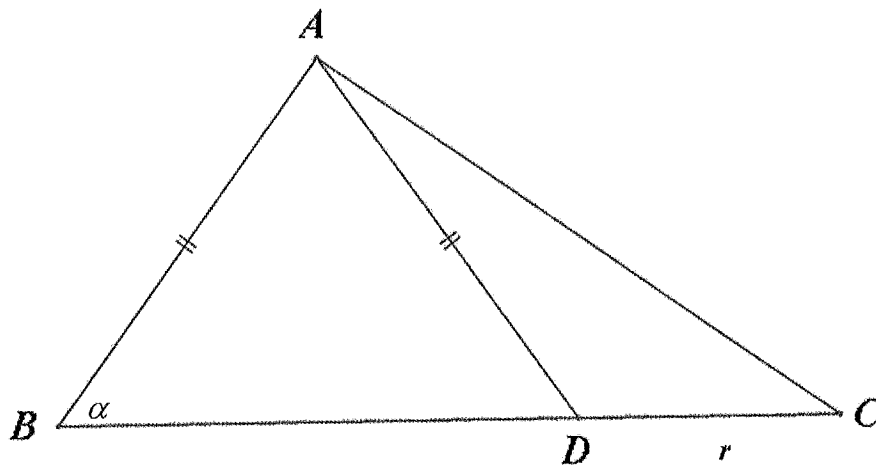

(a) Show that $AD = \frac{r}{\cos \alpha}$ (4)

(b) Now determine the area of ΔADC , in terms of α and r . (4)

[14]

TOTAL MARKS: 75

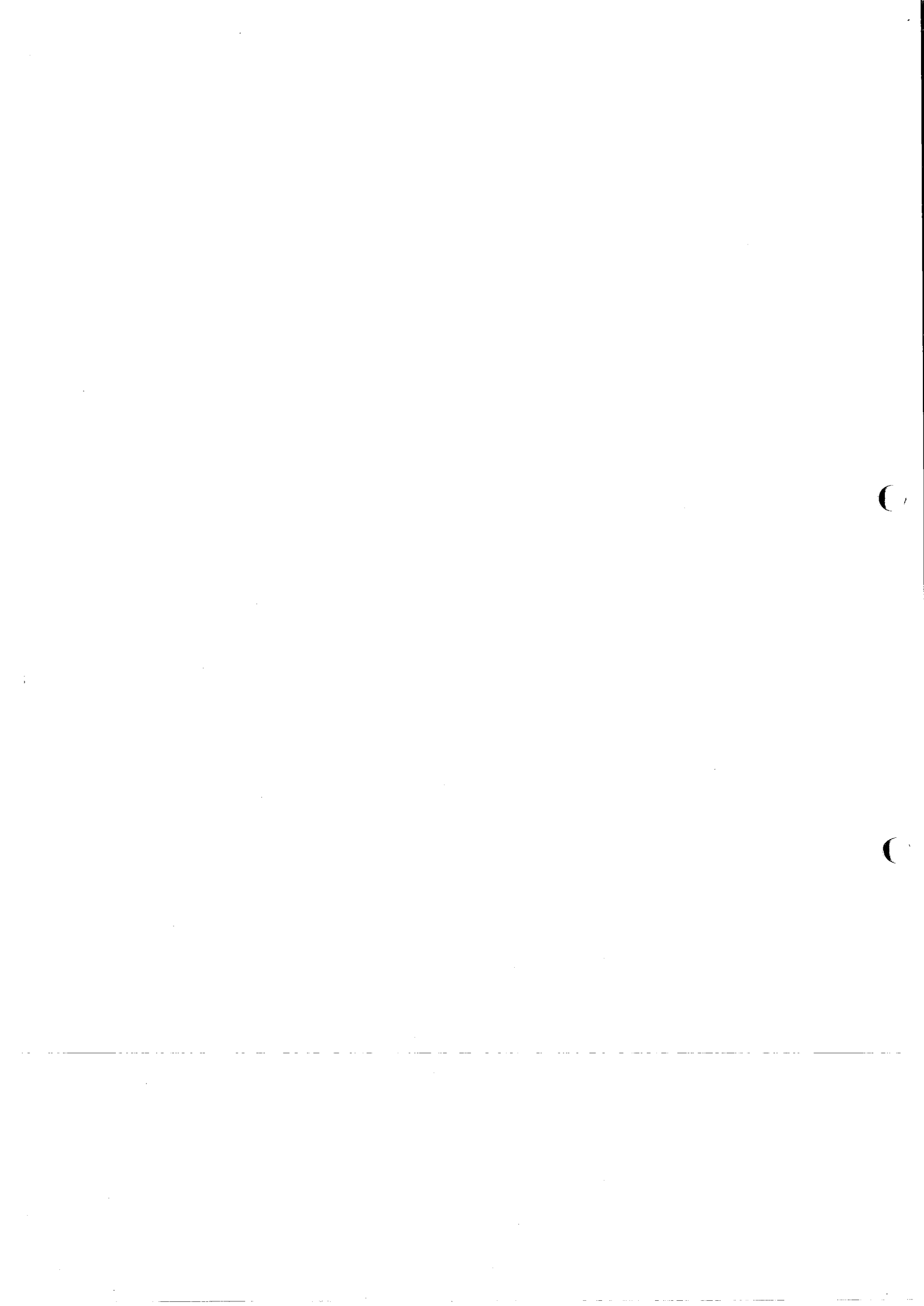



Education

KwaZulu-Natal Department of Education
REPUBLIC OF SOUTH AFRICA

MATHEMATICS
MEMORANDUM
COMMON TEST
SEPTEMBER 2016

**NATIONAL
SENIOR CERTIFICATE**

GRADE 11

N.B. This memorandum consists of 7 pages.

QUESTION 1

1.1 1.1.1	Travel by				(2)
	Game reserve	Sea	aeroplane	Total	
	Male 250	70	180	500	2A for 5 correct values 1A for 3 or 4 correct values
	Female 150	100	160	410	
	Total 400	170	340	910	
1.1.2a	$\frac{400}{910}$ ✓	/ 0,44			1 CA for answer (1)
1.1.2b	$\frac{410}{910} = \frac{41}{91}$ ✓	/ 0,45			1 CA for answer (1)
1.1.2c	$\frac{150}{910} = \frac{15}{91}$ ✓	/ 0,16			1 CA for answer (1)
1.1.2d	$\frac{410}{910} + \frac{400}{910} = \frac{150}{910}$ ✓	/ 0,73			1 CA for using correct formula 1 CA for answer (2)
1.1.3	$P(A \text{ and } B) = \frac{150}{910} \times \frac{15}{91} = 0,16$ / 0,164 $P(A) \times P(B) = \frac{410}{910} \times \frac{400}{910} = \frac{1640}{8281} = 0,20$ / 0,198 $P(A) \times P(B) \neq P(A \text{ and } B)$ Not independent ✓				ICA for calculating $P(A) \times P(B)$ ICA for $P(A) \times P(B) \neq P(A \text{ and } B)$ ICA for concluding (3)

1.2.1		<p>IA for first branching: into S and IP</p> <p>IA for branching from S into R (within 24h), R (after 24h) and NR</p> <p>IA for branching from IP into R (within 24h), R (after 24h) and NR</p>	(3)
1.2.2	<p>S: syndicates; IP: individual persons. R: recovered; NR: not recovered</p> <p>$70\% \times 10\% = 0,07$ OR $0,7 \times 0,1 = 0,07$</p>	<p>IA for $70\% \times 10\%$ OR $0,7 \times 0,1$ IA for answer</p>	(2)
1.2.3	<p>$70\% \times 60\% + 30\% \times 30\%$ $= 0,51$ OR $0,7 \times 0,6 + 0,3 \times 0,3 = 0,51$</p>	<p>IA for $70\% \times 60\%$ OR $0,7 \times 0,6$ IA for $30\% \times 30\%$ OR $0,3 \times 0,3$ IA for correct answer</p>	(3)
			181

QUESTION 2

2.1	<p>Volume of large cone = $\frac{1}{3}\pi r^2 h$ $= \frac{1}{3}\pi (12)^2 (27) \checkmark$ $= 1296\pi \checkmark$</p> <p>Volume of small cone = $\frac{1}{3}\pi r^2 h$ $= \frac{1}{3}\pi (6)^2 (13,5)$ $= 162\pi \checkmark$</p> <p>Volume of frustum = $1296\pi - 162\pi$ $= 1134\pi \checkmark$</p>	<p>IA for substitution</p> <p>ICA for answer</p> <p>IA for answer</p> <p>ICA for answer</p>	(4)
2.2	<p>Volume of sphere = $\frac{4}{3}\pi r^3$ $\frac{4}{3}\pi r^3 = 1134\pi \checkmark$ $r^3 = 850,5 \checkmark$ $r = 9,47 \text{ cm} \checkmark$</p>	<p>ICA for equating</p> <p>ICA for simplification</p> <p>ICA for answer</p>	(3)
			171

QUESTION 3

3.1	$p^2 = 17^2 - (-15)^2 \checkmark$	IA for using Pythagoras	
3.1.1	$p = -8 \checkmark$	IA for correct answer	(2)
3.1.2 (a)	$\cos \theta = \frac{-15}{17} \checkmark$	IA for answer	(1)
3.1.2 (b)	$\tan (180^\circ - \theta) = -\tan \theta \checkmark$ $= \frac{-8}{15} \checkmark$	IA for correct reduction	
3.1.2 (c)	$\sin (\theta - 360^\circ) \cdot \cos (90^\circ - \theta)$ $= \sin \theta \cdot \sin \theta \checkmark \checkmark$ $= \sin^2 \theta$ $= \left(\frac{-8}{17}\right)^2$ $= \frac{64}{289} \checkmark$	IA for $\sin(\theta - 360^\circ) = \sin \theta$ IA for $\cos(90^\circ - \theta) = \sin \theta$	(2)
3.1.3	$\sin \theta = \frac{-8}{17} = \frac{y}{10} \checkmark$ $17y = -80$ $y = \frac{-80}{17}$ or $-4,71 \checkmark$ $\cos \theta = \frac{-15}{17} = \frac{x}{10} \checkmark$ $17x = -150$ $x = \frac{-150}{17}$ or $-8,82 \checkmark$	ICA for equating the ratio	(3)
		ICA for answer	
		ICA for equating the ratio	
		ICA for answer	(4)

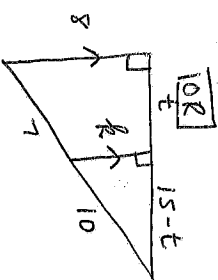

$\frac{15-t}{t} = \frac{10}{7}$
 $t = 6,18$
 $\therefore x = -8,82$
 $\frac{8}{8} = \frac{10}{7}$
 $8 = 4,71$
 $y = -4,71$

3.2	$\frac{\sqrt{\cos x} \cdot 1}{\sqrt{1 - \sin x}} + \frac{(-\tan x)}{\sqrt{1 - \sin x}}$ $= \frac{\cos x \cdot 1}{1 - \sin x} - \frac{\sin x}{\cos x}$ $= \frac{\cos^2 x - \sin x(1 - \sin x)}{\cos x(1 - \sin x)}$ $= \frac{\cos^2 x - \sin x + \sin^2 x}{\cos x(1 - \sin x)}$ $= \frac{\sqrt{1 - \sin x}}{\cos x(1 - \sin x)}$ $= \frac{1}{\cos x}$	<p>1A for $\cos(-x) = \cos x$ 1A for $\tan 225^\circ = 1$ and $\sin 90^\circ = 1$ 1A for $\tan(360^\circ - x) = -\tan x$ 1A for $\tan x = \frac{\sin x}{\cos x}$</p> <p>1 CA for adding fractions</p> <p>1 CA for $\sin^2 x + \cos^2 x = 1$</p> <p>1 CA for answer</p>	(7)
3.3	$\text{LHS} = \frac{2 \sin^2 x}{2 \sin x - 2 \sin x \cos x}$ $= \frac{2 \sin^2 x}{2 \sin x(1 - \cos^2 x)}$ $= \frac{2 \sin^2 x}{2 \sin x(1 - \cos^2 x)}$ $= 2 \sin^2 x \times \frac{\cos x}{2 \sin x \cdot \sin^2 x}$ $= \frac{\cos x}{\sin x}$	<p>1A for $\tan x = \frac{\sin x}{\cos x}$</p> <p>1A for simplifying denominator</p> <p>1A for factorizing</p> <p>1 A for $1 - \cos^2 x = \sin^2 x$</p>	(4)
3.4	$\sin(2x + 15^\circ) = \sin[90^\circ - (\frac{1}{2}x - 15^\circ)]$ $\sin(2x + 15^\circ) = \sin(105^\circ - \frac{1}{2}x)$ $2x + 15^\circ = 105^\circ - \frac{1}{2}x + k \cdot 360^\circ$ $2\frac{1}{2}x = 90^\circ + k \cdot 360^\circ$ <p>or</p> $2x + 15^\circ = 180^\circ - (105^\circ - \frac{1}{2}x) + k \cdot 360^\circ$ $2x + 15^\circ = 75^\circ + \frac{1}{2}x + k \cdot 360^\circ$ $1\frac{1}{2}x = 60^\circ + k \cdot 360^\circ$ $x = 40^\circ + k \cdot 240^\circ, k \in \mathbb{Z}$	<p>1A for writing in terms of sin</p> <p>1 CA $2x + 15^\circ = 105^\circ - \frac{1}{2}x + k \cdot 360^\circ$</p> <p>1 CA $x = 36^\circ + k \cdot 144^\circ, k \in \mathbb{Z}$</p> <p>1 CA $2x + 15^\circ = 180^\circ - (105^\circ - \frac{1}{2}x) + k \cdot 360^\circ$</p> <p>1 CA $x = 40^\circ + k \cdot 240^\circ, k \in \mathbb{Z}$</p>	(5)

QUESTION 4

4.1	$a = 1 \checkmark$ $b = -45^\circ \checkmark$ $c = -2 \checkmark$	3A for values of a, b and c	(3)
4.2	$p = 0,51 \checkmark$	1A for answer	(1)
4.2.1	$q = 165,36^\circ \checkmark$ (or $165,66^\circ$ or $165,23^\circ$)	1A for answer	(1)
4.3	$[-45^\circ; 0^\circ] \checkmark \cup [135^\circ; 180^\circ] \checkmark$	1A for $[-45^\circ; 0^\circ]$ 1A for $[135^\circ; 180^\circ]$	(2)
4.4	$y = \cos x \checkmark$	1A for answer	(1)
			[8]

QUESTION 5

5.1		1A for applying cosine rule	(3)
5.1.1	$AC^2 = AB^2 + BC^2 - 2(AB)(BC)\cos \hat{B} \checkmark$ $= 107^2 + 68^2 - 2 \cdot 107 \cdot 68 \cdot \cos 79^\circ \checkmark$ $= 13296,3475 \checkmark$ $AC = 115,31 \text{ mm} \checkmark$	1A for substitution in formula	
5.1.2	$\frac{DC}{AC} = \tan 22^\circ \checkmark$ $DC = 115,31 \cdot \tan 22^\circ \checkmark$ $= 46,59 \text{ mm} \checkmark$	1 A for ratio ICA for simplification ICA for answer	(3)

5.2	$\frac{1}{2} a b \sin C \checkmark$	1M for correct formula	(1)
5.2.2 (a)	$BD = 2r$ $BAD = 180^\circ - 2\alpha \checkmark$ $\frac{AD}{\sin \hat{B}} = \frac{BD}{\sin \hat{A}D} \checkmark$ $\frac{AD}{\sin \alpha} = \frac{2r}{\sin(180^\circ - 2\alpha)} \checkmark$ $AD = \frac{2r \sin \alpha}{\sin 2\alpha}$ $= \frac{2r \sin \alpha}{2 \sin \alpha \cos \alpha} \checkmark$ $= \frac{r}{\cos \alpha}$	1A for finding BAD 1A for applying sine rule 1A for correct substitution 1CA for simplification/substitution	(4)
5.2.2 (b)	$A\hat{D}C = 180^\circ - \alpha \checkmark$ $\therefore \text{Area of } \Delta ADC = \frac{1}{2} AD \cdot r \cdot \sin(180^\circ - \alpha)$ $= \frac{1}{2} \frac{r}{\cos \alpha} \cdot r \sin \alpha \checkmark$ $= \frac{1}{2} r^2 \frac{\sin \alpha}{\cos \alpha} \checkmark$ $= \frac{1}{2} r^2 \cdot \tan \alpha \checkmark$	1A for finding ADC 1A for applying area rule 1A for substituting $AD = \frac{r}{\cos \alpha}$ and $\sin(180^\circ - \alpha) = \sin \alpha$ 1A for answer	(4) [14]

TOTAL MARKS: 75