



basic education

Department:
Basic Education
REPUBLIC OF SOUTH AFRICA

NATIONAL SENIOR CERTIFICATE

GRADE 12

**LIFE SCIENCES P2
FEBRUARY/MARCH 2018**

MARKS: 150

TIME: 2½ hours

This question paper consists of 16 pages.

INSTRUCTIONS AND INFORMATION

Read the following instructions carefully before answering the questions.

1. Answer ALL the questions.
2. Write ALL the answers in the ANSWER BOOK.
3. Start the answers to EACH question at the top of a NEW page.
4. Number the answers correctly according to the numbering system used in this question paper.
5. Present your answers according to the instructions of each question.
6. Do ALL drawings in pencil and label them in blue or black ink.
7. Draw diagrams, tables or flow charts only when asked to do so.
8. The diagrams in this question paper are NOT necessarily drawn to scale.
9. Do NOT use graph paper.
10. You must use a non-programmable calculator, protractor and a compass, where necessary.
11. Write neatly and legibly.

SECTION A**QUESTION 1**

1.1 Various options are provided as possible answers to the following questions. Choose the answer and write only the letter (A to D) next to the question number (1.1.1 to 1.1.9) in the ANSWER BOOK, for example 1.1.10 D.

1.1.1 A molecule of RNA is copied from DNA by the process of ...

- A transcription.
- B mitosis.
- C mutation.
- D translation.

1.1.2 Evidence supporting the evolution theory is obtained by studying the structure of vertebrate forelimbs.

This type of evidence for evolution is best described as ...

- A biogeography.
- B modification by descent.
- C DNA evidence.
- D genetic evidence.

1.1.3 What is the percentage chance of a woman having a female child?

- A 25%
- B 100%
- C 50%
- D 75%

1.1.4 A small section of mRNA has the following sequence of bases that codes for different amino acids:

G C U C G U U A A

Which ONE of the following is the CORRECT representation of the anticodons and number of amino acids coded for by this section?

	ANTICODONS	NUMBER OF AMINO ACIDS
A	C G A G C A A U U	9
B	C G A G C A A U U	3
C	C G A G C A A T T	9
D	C G A G C A A T T	3

1.1.5 If a recessive allele on the X-chromosome is passed on to the offspring it is an example of ...

- A sex-linked inheritance.
- B incomplete dominance.
- C multiple alleles.
- D co-dominance.

1.1.6 The diagram below shows the DNA profiles of a child, her mother and four males. There is uncertainty about who the biological father is. To establish paternity, DNA profiling was conducted.

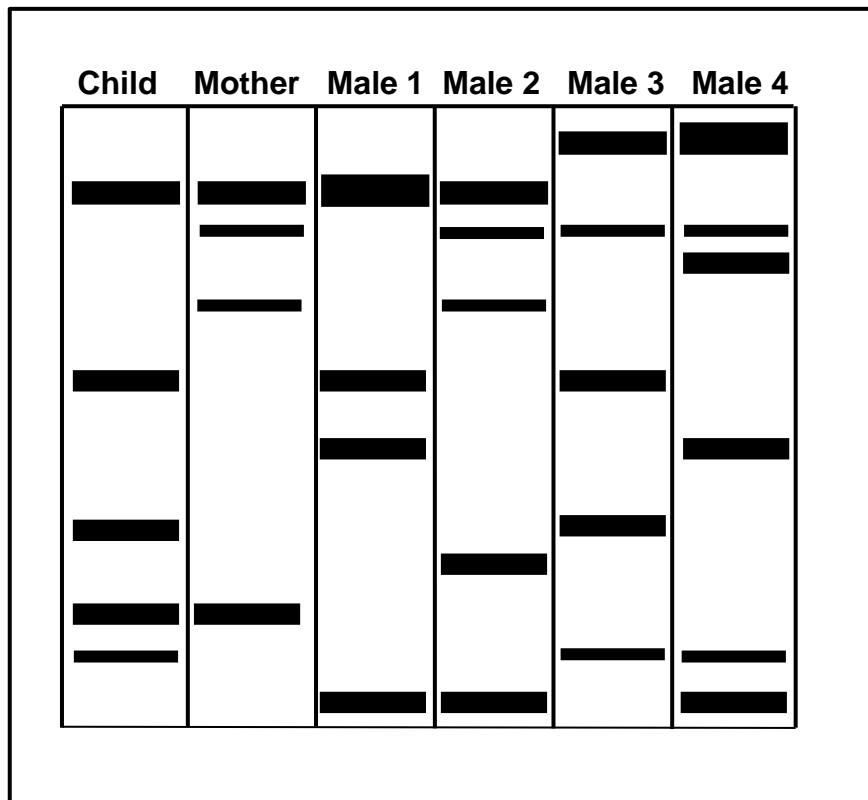

Which male is the biological father of this child?

- A Male 1
- B Male 2
- C Male 3
- D Male 4

1.1.7 Which ONE of the following is the correct genus and scientist for the discovery of the 'Taung Child' fossil?

- A *Ardipithecus*; Raymond Dart
- B *Ardipithecus*; Tim White
- C *Australopithecus*; Raymond Dart
- D *Australopithecus*; Tim White

- 1.1.8 Different frogs, which all belong to the genus *Lithobates*, are found in the same forest. The graph below shows their mating activity.

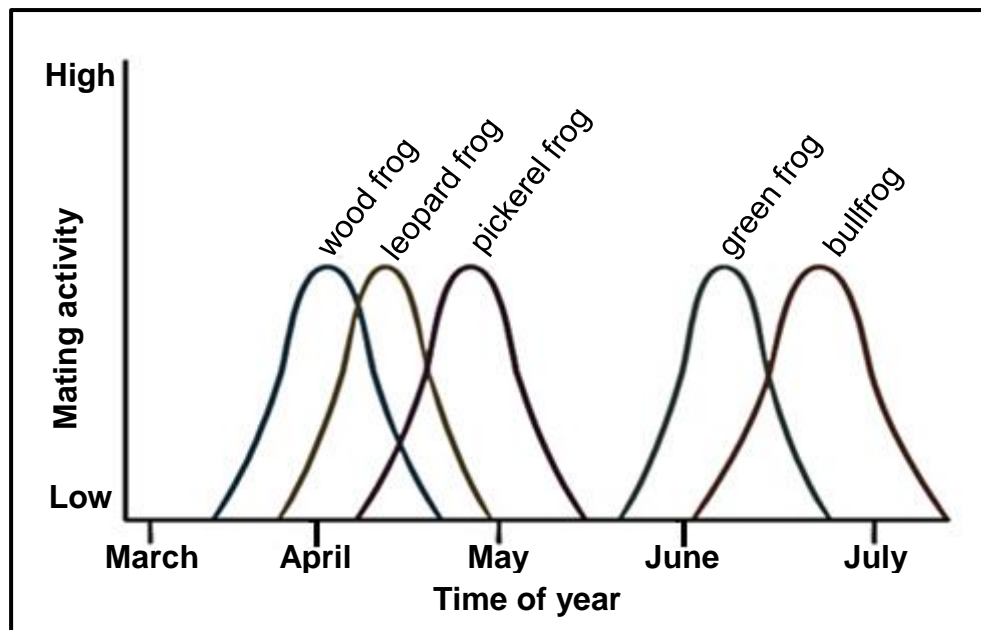

Based on the information, what kind of isolating mechanism is most likely keeping the bullfrogs and wood frogs as separate species?

- A Geographic isolation through the presence of geographic barriers
 - B Reproductive isolation through species-specific courtship behaviour
 - C Reproductive isolation through breeding at different times of the year
 - D Reproductive isolation through the production of infertile offspring
- 1.1.9 Which ONE of the following statements is CORRECT for the 'Out of Africa' hypothesis?

- A All modern humans originated in Africa and migrated to other parts of the world.
- B All modern humans evolved from African apes and then migrated to other parts of the world.
- C The most developed artefacts (tools; cutlery; art) were found in Africa.
- D An analysis of mutations on the mitochondrial DNA shows that the oldest male ancestors were located in Africa. (9 x 2)

(18)

1.2 Give the correct **biological term** for each of the following descriptions. Write only the term next to the question number (1.2.1 to 1.2.8) in the ANSWER BOOK.

- 1.2.1 The type of RNA containing anticodons
- 1.2.2 The process during which genetically identical organisms are formed using biotechnology
- 1.2.3 Undifferentiated animal cells that can form any type of tissue
- 1.2.4 Type of inheritance where none of the two alleles is dominant over the other and an intermediate phenotype is produced
- 1.2.5 The breeding of organisms by humans to achieve a desirable phenotype
- 1.2.6 The point of crossing over between two adjacent chromosomes
- 1.2.7 The organelle in a cell where translation occurs
- 1.2.8 The variety of living organisms on Earth (8 x 1) **(8)**

1.3 Indicate whether each of the statements in COLUMN I applies to **A ONLY**, **B ONLY**, **BOTH A AND B** or **NONE** of the items in COLUMN II. Write **A only**, **B only**, **both A and B**, or **none** next to the question number (1.3.1 to 1.3.3) in the ANSWER BOOK.

COLUMN I		COLUMN II	
1.3.1	Contains the sugar ribose	A:	DNA
		B:	RNA
1.3.2	Chromosomes align at the equator	A:	Metaphase I
		B:	Metaphase II
1.3.3	Produced the first X-ray image of the DNA molecule	A:	Rosalind Franklin
		B:	Watson and Crick

(3 x 2) **(6)**

1.4 The diagram represents a portion of a nucleic acid.

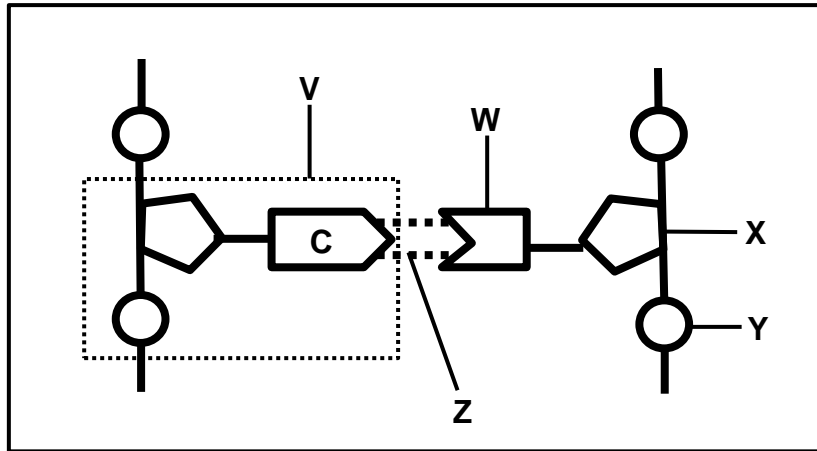

- 1.4.1 Name the nucleic acid. (1)
- 1.4.2 Name TWO places in animal cells where this nucleic acid may be found. (2)
- 1.4.3 Identify:
 - (a) Portion **V** (1)
 - (b) Nitrogenous base **W** (1)
 - (c) Molecule **Y** (1)
 - (d) Bond **Z** (1)
- 1.4.4 What is the natural shape of this molecule? (1)
- 1.4.5 Name the process during which this molecule makes a copy of itself. (1)

(9)

1.5 The diagram below shows possible evolutionary relationships among some hominids.

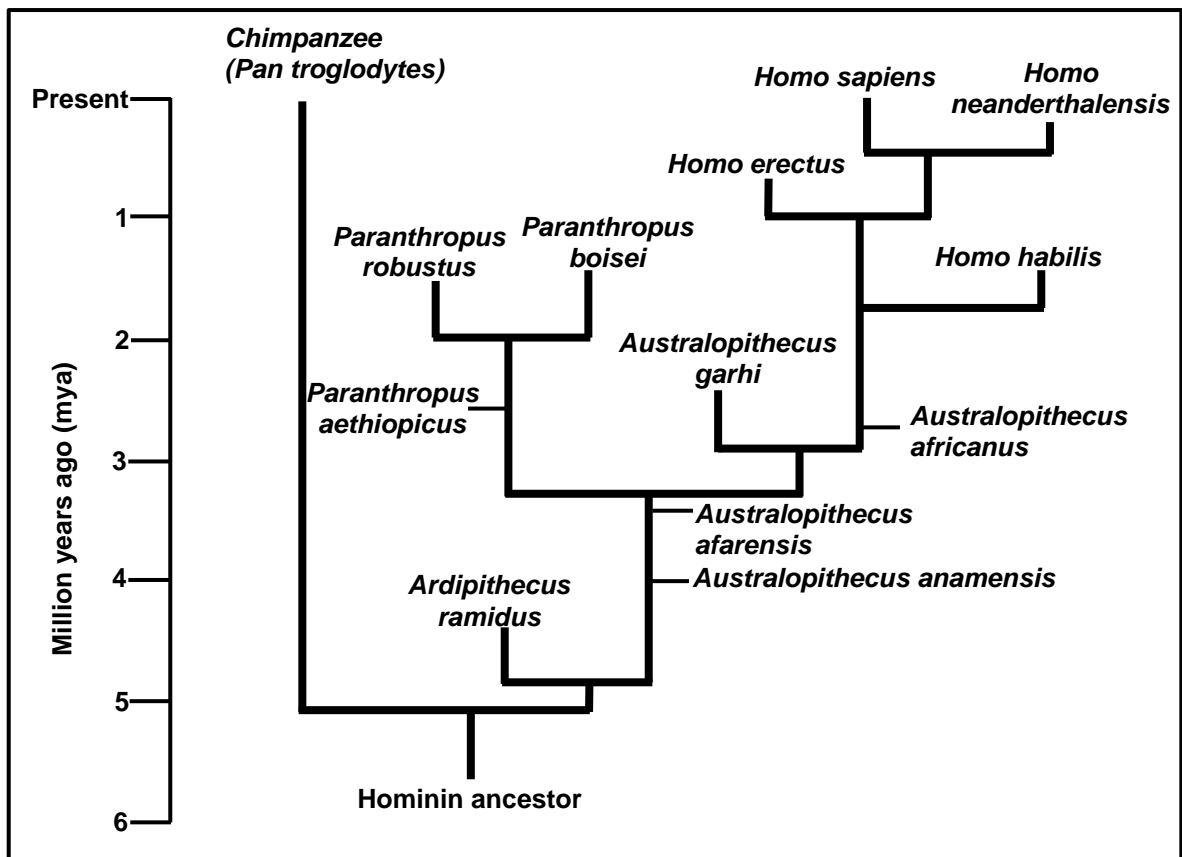

- 1.5.1 What is this type of diagram called? (1)
- 1.5.2 How many of EACH of the following are represented in the diagram:
 - (a) Genera (1)
 - (b) *Homo* species (1)
- 1.5.3 Name the species that have *Paranthropus aethiopicus* as a common ancestor. (2)
- 1.5.4 When did:
 - (a) *Ardipithecus ramidus* become extinct (1)
 - (b) *Homo erectus* first appear (1)
- 1.5.5 Name the:
 - (a) Hominid species that existed at the same time as *Homo sapiens* (1)
 - (b) First *Homo* species to use tools (1)

TOTAL SECTION A: 50

SECTION B

QUESTION 2

2.1 The karyotype below shows the chromosomes of a person with Down syndrome.

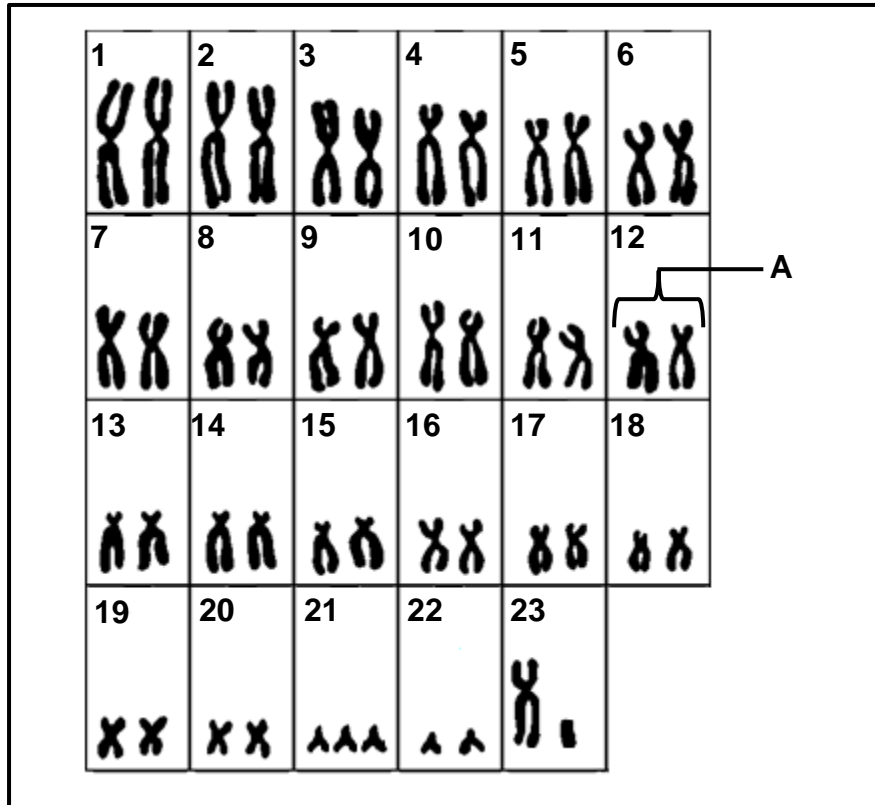

- 2.1.1 Give the label for **A**. (1)
 - 2.1.2 How many autosomes are there in a nucleus of this cell? (1)
 - 2.1.3 Name the type of chromosomes at position **23**. (1)
 - 2.1.4 What evidence suggests that this is a karyotype of a male? (1)
 - 2.1.5 Name the type of mutation represented in the diagram. (1)
 - 2.1.6 Describe the events that led to Down syndrome. (6)
- (11)**

- 2.2 The diagram below shows the pattern of inheritance of deafness in a family. The letter **H** represents the allele for hearing and **h** represents the allele for deafness.

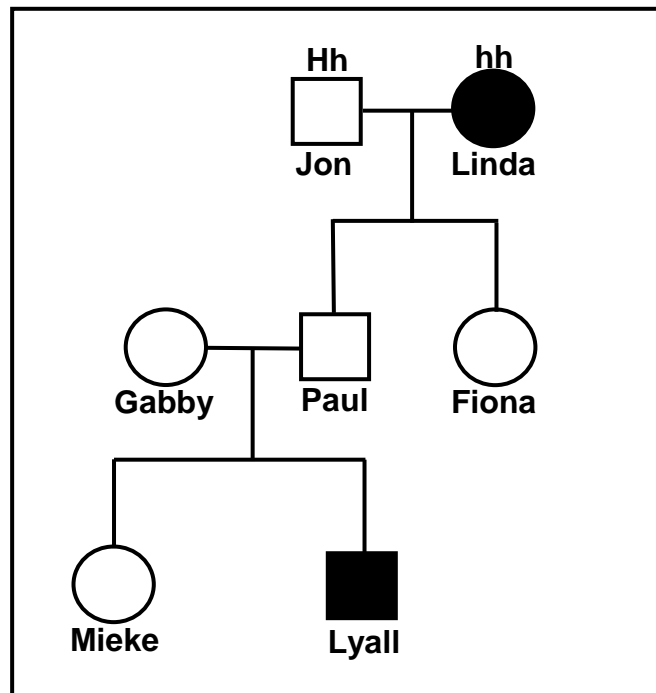

- 2.2.1 How many of EACH of the following are represented in this diagram?

(a) Males (1)

(b) Generations (1)

- 2.2.2 Give the:

(a) Phenotype of Jon (1)

(b) Genotype of Paul (1)

- 2.2.3 Both Lyall's parents can hear, yet he is deaf.

Explain how he inherited deafness. (2)

- 2.2.4 Lyall marries a woman who is homozygous dominant for hearing. Use a genetic cross to show the percentage chance of them having a deaf child.

(7)
(13)

2.3 The extract below is about human evolution.

In 2004 scientists in Indonesia discovered the first fossil of the species *Homo floresiensis* along with stone tools and animal remains. The fossil was made up of a nearly complete skull and skeleton, including hand and foot bones and a pelvis.

Dating of the tools suggests that *H. floresiensis* may have lived from as early as 95 000 years ago until about 12 000 years ago.

Researchers closely analysed three wrist bones and found that they more closely resembled those of apes than modern humans. This finding implied that *H. floresiensis* was indeed a separate species from modern humans.

They had skulls that resembled early *Homo* species. This included a flat forehead and a short, flat face; however, their teeth and jaws more closely resembled *Australopithecus*.

The scans of the skull suggested that the brain volume of *H. floresiensis* was about 426 cm³; around one-third the size of the modern human brain which has an average volume of about 1 300 cm³. The findings suggested that *H. erectus* may be the ancestor of *H. floresiensis*, as *H. erectus* had brains about 860 cm³ in size or, alternatively, it may have evolved from *H. habilis*, whose brains were about 600 cm³ in size.

- 2.3.1 Name the TWO lines of evidence for human evolution that is referred to in the extract above. (2)
- 2.3.2 How long did *Homo floresiensis* exist on Earth? (1)
- 2.3.3 Name ONE *Homo* ancestor mentioned in the extract. (1)
- 2.3.4 State THREE features of the jaw of *H. floresiensis* that might have led scientists to believe that it resembled that of *Australopithecus*, rather than of a *Homo* species. (3)
- 2.3.5 Describe ONE feature of the skull that can be used as evidence for bipedalism. (2)
- 2.3.6 State TWO similarities between the hands of African apes and modern humans. (2)
- 2.3.7 Draw a table to show the brain volumes of the different *Homo* species, using information from the extract. (5)
- (16)**
[40]

QUESTION 3

- 3.1 The table below shows the percentage of the populations with different blood groups for two countries.

BLOOD GROUP	PERCENTAGE OF POPULATION	
	COUNTRY Q	COUNTRY R
O	40	20
A	10	35
B	45	40
AB	5	5

- 3.1.1 Which blood group shows the greatest percentage difference between the two countries? (1)
- 3.1.2 The population size of country **Q** is 5 million people.
Calculate the number of people who have blood group **O**. Show ALL your working. (3)
- 3.1.3 Explain how the inheritance of blood group **AB** is an example of co-dominance. (2)
- 3.1.4 Explain why blood groups are considered an example of discontinuous variation. (2)
- 3.1.5 In the inheritance of blood groups, give the:
- (a) Recessive allele (1)
- (b) Phenotype of an individual who is homozygous recessive (1)
- (10)**

3.2 Read the extract below.

The red-bellied black snake (*Pseudechis porphyriacus*) and the green tree snake (*Denderelaphis punctulatus*) are predators that sometimes feed on cane toads (*Bufo marinus*) that contain a toxin that may kill them.

The snakes consume the toads by swallowing them whole. A decrease in the average jaw size of the snakes has been observed over a period of 70 years. Some scientists believe that this may be an example of punctuated equilibrium. With this change it was also noted that the snakes could no longer swallow the large cane toads. This has resulted in an increase in the survival of the snakes.

- 3.2.1 Define *punctuated equilibrium*. (3)
- 3.2.2 What characteristic of the toad species protects it from predation? (1)
- 3.2.3 Explain how the change in jaw size helped the snakes to survive. (3)
- 3.2.4 How would Lamarck have explained the development of a small jaw size in the snakes? (4)
- (11)**

- 3.3 In a plant species two characteristics, flower colour and plant height, were studied. Each of these characteristics has two variations: flowers may be red or white in colour and the plants may be tall or short.

Plants that are heterozygous for flower colour have red flowers and plants that are homozygous recessive for plant height are short.

The alleles for each characteristic are shown in the table below.

CHARACTERISTIC	DOMINANT ALLELE	RECESSIVE ALLELE
Flower colour	F	f
Plant height	H	h

- 3.3.1 What is the term given for a genetic cross involving two characteristics? (1)
- 3.3.2 Give the:
- (a) Dominant phenotype for flower colour (1)
 - (b) Recessive phenotype for plant height (1)
 - (c) Phenotype of a plant that is heterozygous for flower colour and homozygous dominant for plant height (2)
 - (d) Genotype of a white flowering, short plant (2)
- 3.3.3 State Mendel's Law of Dominance. (3)
- (10)**

3.4 Study the extract and the information provided.

An insecticide is used by farmers to control insect populations of *Plodia interpunctella* which feeds on stored grain. Farmers treat the grain with the insecticide to prevent an insect infestation.

This insecticide is extremely poisonous to certain insects, yet causes little or no harm to humans and beneficial insects.

In recent years it has been noticed that this insecticide is no longer effective in controlling insect populations of *Plodia interpunctella*.

Scientists hypothesised that insect populations that had previously been exposed to the insecticide had a higher survival rate when the grain was treated again.

In an investigation to test this hypothesis, they:

- Identified storage bins that had previously been treated with the insecticide and bins that had never been treated with the insecticide
- Collected a sample of 300 insects from each bin
- Kept each sample in a separate container of equal size and the same conditions
- Sprayed the same concentration and volume of insecticide over both containers
- Allowed 24 hours for the insecticide to take effect
- Counted the number of insects that survived in each container

The results are given in the table below:

PREVIOUS EXPOSURE TO INSECTICIDE	NUMBER OF INSECTS THAT SURVIVED
With previous exposure to insecticide	182
No previous exposure to insecticide	66

3.4.1 Give the:

- (a) Independent variable (1)
- (b) Dependent variable (1)

3.4.2 State THREE factors that were kept constant in this investigation. (3)

3.4.3 Give TWO reasons why the scientists' results may not be reliable. (2)

3.4.4 State a conclusion for this investigation. (2)

(9)
[40]

TOTAL SECTION B: 80

SECTION C**QUESTION 4**

Describe how a gene mutation may influence the structure of a protein. Also use ONE example to describe the role of mutations in evolution in present times.

Content: (17)
Synthesis: (3)

NOTE: NO marks will be awarded for answers in the form of tables, flow charts or diagrams.

TOTAL SECTION C: 20
GRAND TOTAL: 150