

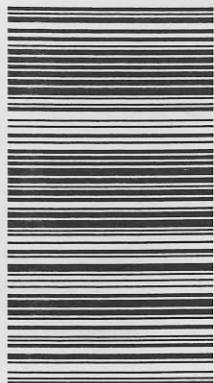

basic education

Department:
Basic Education
REPUBLIC OF SOUTH AFRICA



**NATIONAL
SENIOR CERTIFICATE**

GRADE 12

MATH.1

MATHEMATICS P1

NOVEMBER 2019

MARKS: 150

TIME: 3 hours

This question paper consists of 9 pages and 1 information sheet

MORNING SESSION



INSTRUCTIONS AND INFORMATION

Read the following instructions carefully before answering the questions.

1. This question paper consists of 11 questions.
2. Answer ALL the questions.
3. Number the answers correctly according to the numbering system used in this question paper.
4. Clearly show ALL calculations, diagrams, graphs, etc. that you have used in determining your answers.
5. Answers only will NOT necessarily be awarded full marks.
6. You may use an approved scientific calculator (non-programmable and non-graphical), unless stated otherwise.
7. If necessary, round off answers to TWO decimal places, unless stated otherwise.
8. Diagrams are NOT necessarily drawn to scale.
9. An information sheet with formulae is included at the end of the question paper.
10. Write neatly and legibly.



QUESTION 11.1 Solve for x :

1.1.1 $x^2 + 5x - 6 = 0$ (3)

1.1.2 $4x^2 + 3x - 5 = 0$ (correct to TWO decimal places) (3)

1.1.3 $4x^2 - 1 < 0$ (3)

1.1.4 $\left(\sqrt{\sqrt{32+x}}\right)\left(\sqrt{\sqrt{32-x}}\right) = x$ (4)

1.2 Solve simultaneously for x and y :

$y + x = 12$ and $xy = 14 - 3x$ (5)

1.3 Consider the product $1 \times 2 \times 3 \times 4 \times \dots \times 30$.Determine the largest value of k such that 3^k is a factor of this product. (4)**[22]****QUESTION 2**

2.1 Given the quadratic sequence: 321 ; 290 ; 261 ; 234 ;

2.1.1 Write down the values of the next TWO terms of the sequence. (2)

2.1.2 Determine the general term of the sequence in the form $T_n = an^2 + bn + c$. (4)

2.1.3 Which term(s) of the sequence will have a value of 74? (4)

2.1.4 Which term in the sequence has the least value? (2)

2.2 Given the geometric series: $\frac{5}{8} + \frac{5}{16} + \frac{5}{32} + \dots = K$ 2.2.1 Determine the value of K if the series has 21 terms. (3)2.2.2 Determine the largest value of n for which $T_n > \frac{5}{8192}$ (4)**[19]**

QUESTION 3

3.1 Without using a calculator, determine the value of: $\sum_{y=3}^{10} \frac{1}{y-2} - \sum_{y=3}^{10} \frac{1}{y-1}$ (3)

3.2 A steel pavilion at a sports ground comprises of a series of 12 steps, of which the first 3 are shown in the diagram below.

Each step is 5 m wide. Each step has a rise of $\frac{1}{3}$ m and has a tread of $\frac{2}{3}$ m, as shown in the diagram below.

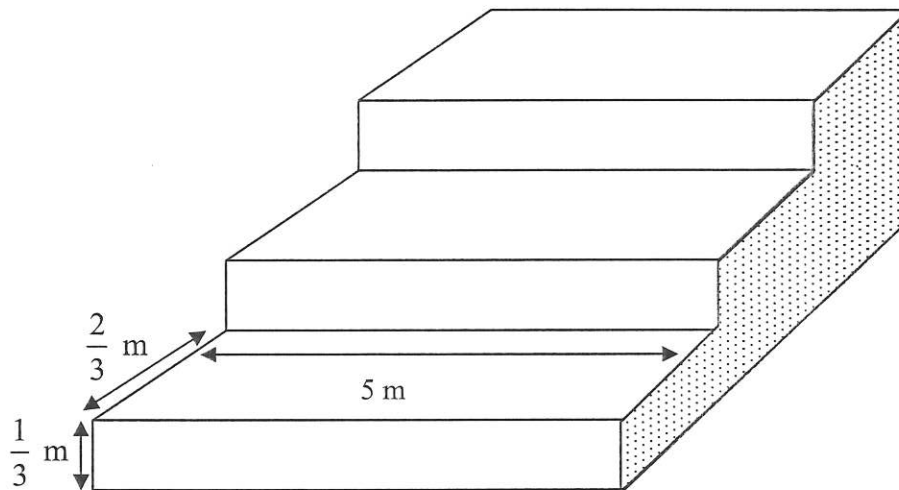

The open side (shaded on sketch) on each side of the pavilion must be covered with metal sheeting. Calculate the area (in m^2) of metal sheeting needed to cover both open sides.

(6)
[9]

QUESTION 4

Below are the graphs of $f(x) = x^2 + bx - 3$ and $g(x) = \frac{a}{x+p}$.

- f has a turning point at C and passes through the x -axis at $(1; 0)$.
- D is the y -intercept of both f and g . The graphs f and g also intersect each other at E and J .
- The vertical asymptote of g passes through the x -intercept of f .

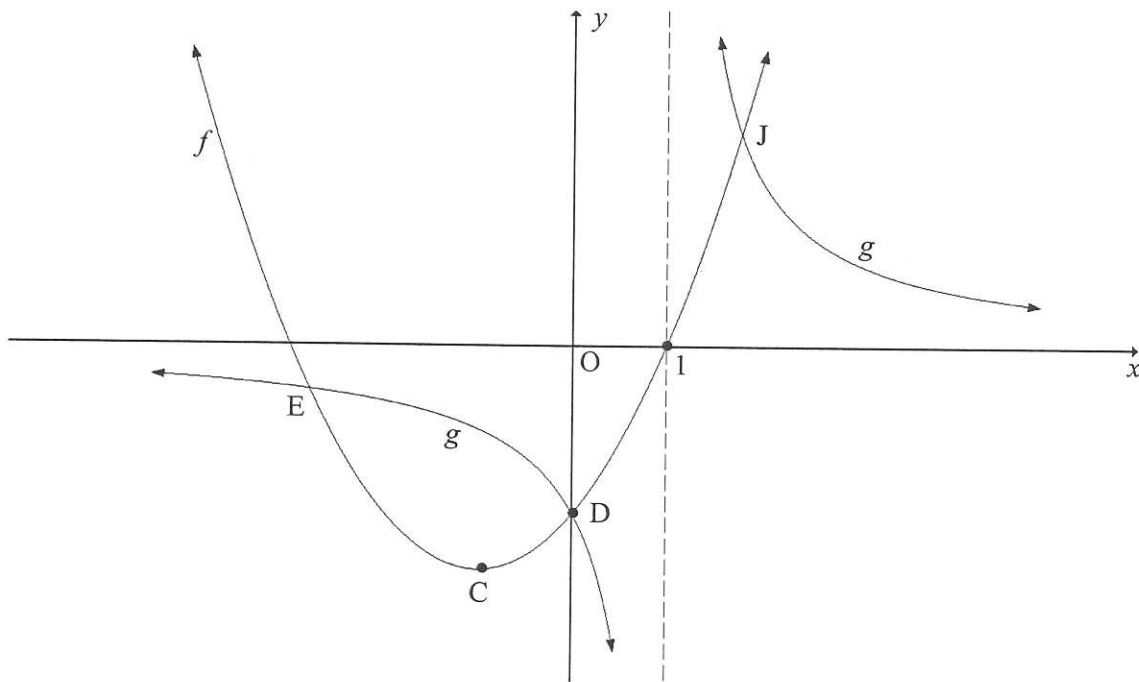

- 4.1 Write down the value of p . (1)
- 4.2 Show that $a = 3$ and $b = 2$. (3)
- 4.3 Calculate the coordinates of C . (4)
- 4.4 Write down the range of f . (2)
- 4.5 Determine the equation of the line through C that makes an angle of 45° with the positive x -axis. Write your answer in the form $y = \dots$ (3)
- 4.6 Is the straight line, determined in QUESTION 4.5, a tangent to f ? Explain your answer. (2)
- 4.7 The function $h(x) = f(m - x) + q$ has only one x -intercept at $x = 0$. Determine the values of m and q . (4)
- [19]**

QUESTION 5

Sketched below is the graph of $f(x) = k^x; k > 0$. The point $(4; 16)$ lies on f .

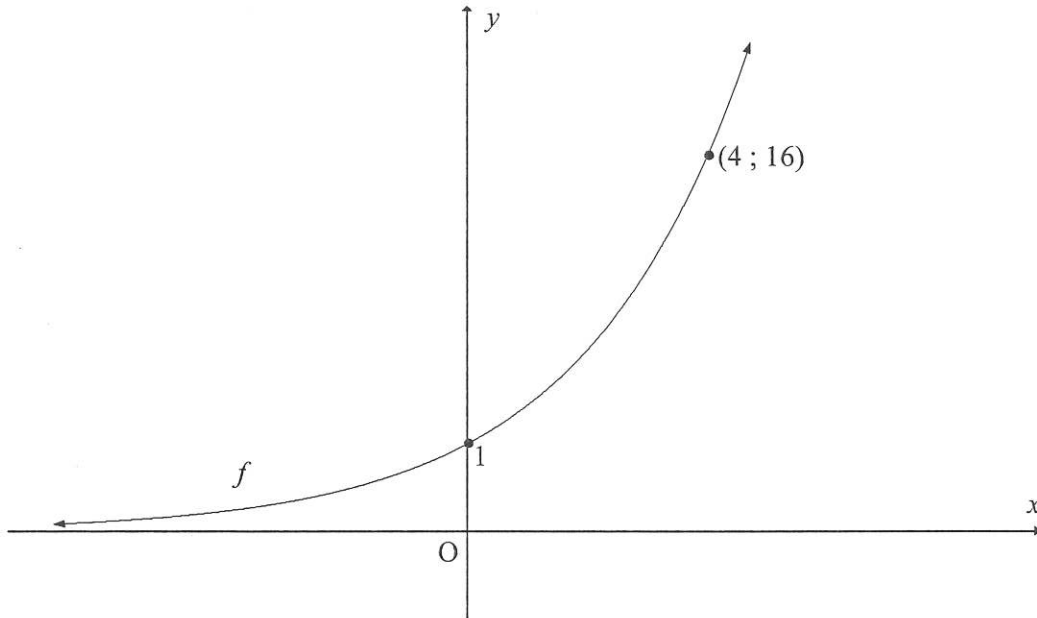

- 5.1 Determine the value of k . (2)
- 5.2 Graph g is obtained by reflecting graph f about the line $y = x$. Determine the equation of g in the form $y = \dots$ (2)
- 5.3 Sketch the graph g . Indicate on your graph the coordinates of two points on g . (4)
- 5.4 Use your graph to determine the value(s) of x for which:
 - 5.4.1 $f(x) \times g(x) > 0$ (2)
 - 5.4.2 $g(x) \leq -1$ (2)
- 5.5 If $h(x) = f(-x)$, calculate the value of x for which $f(x) - h(x) = \frac{15}{4}$ (4)

[16]



QUESTION 6

- 6.1 Two friends, Kuda and Thabo, each want to invest R5 000 for four years. Kuda invests his money in an account that pays simple interest at 8,3% per annum. At the end of four years, he will receive a bonus of exactly 4% of the accumulated amount. Thabo invests his money in an account that pays interest at 8,1% p.a., compounded monthly.

Whose investment will yield a better return at the end of four years? Justify your answer with appropriate calculations. (5)

- 6.2 Nine years ago, a bank granted Mandy a home loan of R525 000. This loan was to be repaid over 20 years at an interest rate of 10% p.a., compounded monthly. Mandy's monthly repayments commenced exactly one month after the loan was granted.

- 6.2.1 Mandy decided to make monthly repayments of R6 000 instead of the required R5 066,36. How many payments will she make to settle the loan? (5)

- 6.2.2 After making monthly repayments of R6 000 for nine years, Mandy required money to fund her daughter's university fees. She approached the bank for another loan. Instead, the bank advised Mandy that the extra amount repaid every month could be regarded as an investment and that she could withdraw this full amount to fund her daughter's studies. Calculate the maximum amount that Mandy may withdraw from the loan account. (4)

[14]

QUESTION 7

- 7.1 Determine $f'(x)$ from first principles if it is given that $f(x) = 4 - 7x$. (4)

- 7.2 Determine $\frac{dy}{dx}$ if $y = 4x^8 + \sqrt{x^3}$ (3)

- 7.3 Given: $y = ax^2 + a$

Determine:

- 7.3.1 $\frac{dy}{dx}$ (1)

- 7.3.2 $\frac{dy}{da}$ (2)

- 7.4 The curve with equation $y = x + \frac{12}{x}$ passes through the point $A(2 ; b)$. Determine the equation of the line perpendicular to the tangent to the curve at A . (4)

[14]



QUESTION 8

After flying a short distance, an insect came to rest on a wall. Thereafter the insect started crawling on the wall. The path that the insect crawled can be described by $h(t) = (t - 6)(-2t^2 + 3t - 6)$, where h is the height (in cm) above the floor and t is the time (in minutes) since the insect started crawling.

- 8.1 At what height above the floor did the insect start to crawl? (1)
- 8.2 How many times did the insect reach the floor? (3)
- 8.3 Determine the maximum height that the insect reached above the floor. (4)
[8]

QUESTION 9

Given: $f(x) = 3x^3$

- 9.1 Solve $f(x) = f'(x)$ (3)
- 9.2 The graphs f , f' and f'' all pass through the point $(0 ; 0)$.
- 9.2.1 For which of the graphs will $(0 ; 0)$ be a stationary point? (1)
- 9.2.2 Explain the difference, if any, in the stationary points referred to in QUESTION 9.2.1. (2)
- 9.3 Determine the vertical distance between the graphs of f' and f'' at $x = 1$. (3)
- 9.4 For which value(s) of x is $f(x) - f'(x) < 0$? (4)
[13]

QUESTION 10

The school library is open from Monday to Thursday. Anna and Ben both studied in the school library one day this week. If the chance of studying any day in the week is equally likely, calculate the probability that Anna and Ben studied on:

- 10.1 The same day (2)
- 10.2 Consecutive days (3)
[5]

QUESTION 11

- 11.1 Events **A** and **B** are independent. $P(A) = 0,4$ and $P(B) = 0,25$.
- 11.1.1 Represent the given information on a Venn diagram. Indicate on the Venn diagram the probabilities associated with each region. (3)
- 11.1.2 Determine $P(A \text{ or NOT } B)$. (2)
- 11.2 Motors Incorporated manufacture cars with 5 different body styles, 4 different interior colours and 6 different exterior colours, as indicated in the table below.

BODY STYLES	INTERIOR COLOURS	EXTERIOR COLOURS
Five body styles	Blue	Silver
	Grey	Blue
	Black	White
	Red	Green
		Red
		Gold

The interior colour of the car must NOT be the same as the exterior colour.

Motors Incorporated wants to display one of each possible variation of its car in their showroom. The showroom has a floor space of 500 m^2 and each car requires a floor space of 5 m^2 .

Is this display possible? Justify your answer with the necessary calculations. (6)
[11]

TOTAL: 150

INFORMATION SHEET

$$x = \frac{-b \pm \sqrt{b^2 - 4ac}}{2a}$$

$$A = P(1 + ni)$$

$$A = P(1 - ni)$$

$$A = P(1 - i)^n$$

$$A = P(1 + i)^n$$

$$T_n = a + (n - 1)d$$

$$S_n = \frac{n}{2}[2a + (n - 1)d]$$

$$T_n = ar^{n-1}$$

$$S_n = \frac{a(r^n - 1)}{r - 1}; r \neq 1$$

$$S_\infty = \frac{a}{1 - r}; -1 < r < 1$$

$$F = \frac{x[(1 + i)^n - 1]}{i}$$

$$P = \frac{x[1 - (1 + i)^{-n}]}{i}$$

$$f'(x) = \lim_{h \rightarrow 0} \frac{f(x + h) - f(x)}{h}$$

$$d = \sqrt{(x_2 - x_1)^2 + (y_2 - y_1)^2}$$

$$M\left(\frac{x_1 + x_2}{2}; \frac{y_1 + y_2}{2}\right)$$

$$y = mx + c$$

$$y - y_1 = m(x - x_1)$$

$$m = \frac{y_2 - y_1}{x_2 - x_1}$$

$$m = \tan \theta$$

$$(x - a)^2 + (y - b)^2 = r^2$$

$$\text{In } \triangle ABC: \quad \frac{a}{\sin A} = \frac{b}{\sin B} = \frac{c}{\sin C}$$

$$a^2 = b^2 + c^2 - 2bc \cdot \cos A$$

$$\text{area } \triangle ABC = \frac{1}{2}ab \cdot \sin C$$

$$\sin(\alpha + \beta) = \sin \alpha \cos \beta + \cos \alpha \sin \beta$$

$$\sin(\alpha - \beta) = \sin \alpha \cos \beta - \cos \alpha \sin \beta$$

$$\cos(\alpha + \beta) = \cos \alpha \cos \beta - \sin \alpha \sin \beta$$

$$\cos(\alpha - \beta) = \cos \alpha \cos \beta + \sin \alpha \sin \beta$$

$$\cos 2\alpha = \begin{cases} \cos^2 \alpha - \sin^2 \alpha \\ 1 - 2\sin^2 \alpha \\ 2\cos^2 \alpha - 1 \end{cases}$$

$$\sin 2\alpha = 2 \sin \alpha \cos \alpha$$

$$\bar{x} = \frac{\sum x}{n}$$

$$\sigma^2 = \frac{\sum_{i=1}^n (x_i - \bar{x})^2}{n}$$

$$P(A) = \frac{n(A)}{n(S)}$$

$$P(A \text{ or } B) = P(A) + P(B) - P(A \text{ and } B)$$

$$\hat{y} = a + bx$$

$$b = \frac{\sum (x - \bar{x})(y - \bar{y})}{\sum (x - \bar{x})^2}$$

