



education

Department:
Education
PROVINCE OF KWAZULU-NATAL

**NATIONAL
SENIOR CERTIFICATE**

GRADE 12

PHYSICAL SCIENCES P1 (PHYSICS)

HALF - YEARLY EXAMINATIONS

JUNE 2020

MARKS : 150

TIME : 3 hours

This question paper consists of 16 pages and 1 data sheet.

INSTRUCTIONS AND INFORMATION TO CANDIDATES

1. Write your name on the **ANSWER BOOK**.
2. This question paper consists of EIGHT questions. Answer ALL the questions in the ANSWER BOOK.
3. Start EACH question on a NEW page in the ANSWER BOOK.
4. Number the answers correctly according to the numbering system used in this question paper.
5. Leave ONE line between two sub questions, for example between QUESTION 2.1 and QUESTION 2.2.
6. You may use a non-programmable calculator.
7. You may use appropriate mathematical instruments.
8. You are advised to use the attached DATA SHEET.
9. Show ALL formulae and substitutions in ALL calculations.
10. Round off your final numerical answers to a minimum of TWO decimal places.
11. Give brief motivations, discussions, et cetera where required.
12. Write neatly and legibly.

SECTION A

QUESTION 1: MULTIPLE-CHOICE QUESTIONS

Four options are provided as possible answers to the following questions. Each question has only ONE correct answer. Write only the letter A, B, C or D next to the question number (1.1 to 1.10) in your ANSWER BOOK.

1.1 The linear momentum of an object is a ...

- A vector quantity with the same direction as the velocity of the object.
- B scalar quantity with the same direction as the velocity of the object.
- C vector quantity with direction opposite to that of the velocity of the object.
- D scalar quantity with direction opposite to that of the velocity of the object.

(2)

1.2 A small object mass m , on the surface of the planet Mars mass M , experiences a gravitational acceleration g . The radius of the Mars is r and the universal gravitational constant is represented by G . Which ONE of the following combinations can be used to determine the magnitude of g on Mars?

A	r	M
B	r	m
C	G	M
D	G	m

- 1.3 A force F applied at an angle θ to the horizontal is pulling a heavy block of weight w along a rough, horizontal floor at a **CONSTANT** velocity. The block stays in contact with the floor. The coefficient of kinetic friction is μ

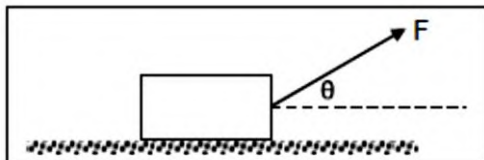

Which **ONE** of the following combinations is correct regarding the magnitudes of the forces, or force components, on the block?

	HORIZONTAL	VERTICAL
A	$F \cos \theta < \mu N$	$N = w$
B	$F \cos \theta = \mu N$	$F \sin \theta + N = w$
C	$F \cos \theta = \mu N$	$N = w$
D	$F \cos \theta > \mu N$	$F \sin \theta + N = w$

- 1.4 Projectile motion is when an object is moving ...
- A vertically upwards or vertically downwards at a constant speed.
 - B vertically upwards or vertically downwards at changing acceleration.
 - C and the only force acting on it, is the force of gravity.
 - D and the two forces acting on it, are the force of gravity and air resistance.
- (2)

- 1.5 Three separate, identical blocks are in contact with each other in a straight line. They are at rest on a smooth, horizontal surface. Each of these blocks has a mass m . Another block with the same dimensions, but with mass $2m$, moving at a velocity v , collides ELASTICALLY and in the same straight line with the three stationary blocks.

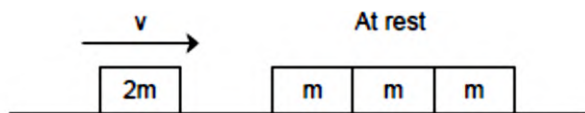

Which one of the following diagrams represents the situation immediately after the collision?

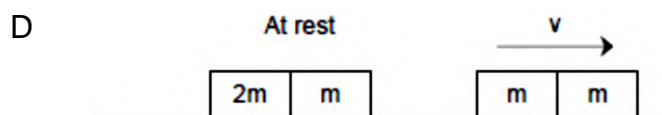
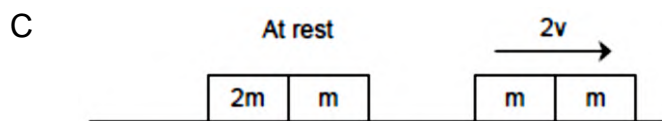
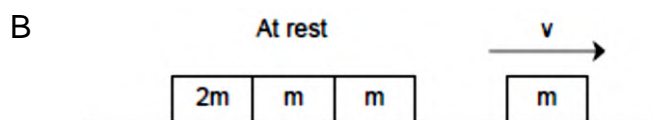
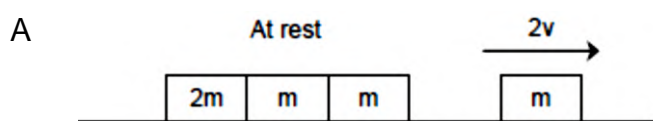

(2)

- 1.6 A car, moving at a constant velocity with kinetic energy K , undergoes a displacement x in time t . If the car's kinetic energy changes to $2K$, it will undergo a displacement of ... in the same time at the new constant velocity.

- A $4x$
 B $2x$
 C $\sqrt{2}x$
 D $\frac{1}{\sqrt{2}}x$

(2)

- 1.7 Which one of the following would result in you hearing a lower pitch than that of a single note played by a trumpet player who is standing on a stage?
- A Play the sound much louder through headphones.
 - B Run away from the trumpet player.
 - C Run towards the trumpet player.
 - D Cover your ears.

- 1.8 Two small, metallic spheres, **P** and **Q**, on insulated stands carry identical negative charges. The distance between their centres is d and the magnitude of the force exerted by **Q** on **P** is F . The distance is then changed to $\frac{1}{2}d$. What is the magnitude of the new force exerted by **Q** on **P** in terms of F ?

- A $\frac{1}{4}F$
- B $\frac{1}{2}F$
- C $2F$
- D $4F$

(2)

- 1.9 Three point charges, Q_1 (negative), Q_2 (positive) and Q_3 (positive), are kept stationary at right angles with respect to one another as indicated below.

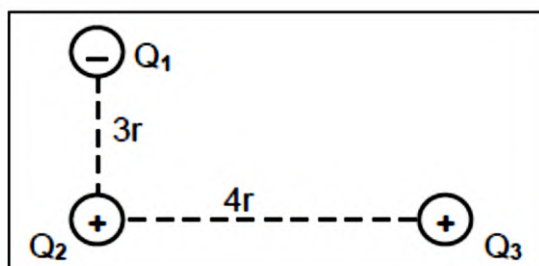

The magnitude of the charge on Q_1 is nine times that of Q_2 ($Q_1 = 9Q_2$). The magnitude of the charge on Q_3 is sixteen times that of Q_2 ($Q_3 = 16Q_2$). The distances between Q_1 and Q_2 and between Q_3 and Q_2 are $3r$ and $4r$ respectively.

Which ONE of the following vector diagrams is the best representation of the net (resultant) electrostatic force on Q_2 due to the presence of Q_1 and Q_3 ?

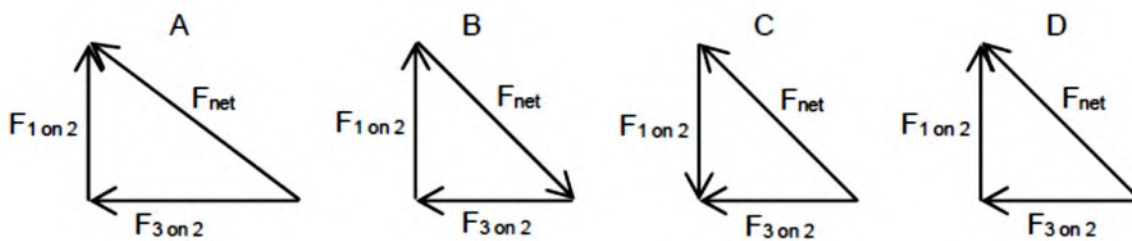

- 1.10 The battery in the circuit diagram below has an emf of 12 V and negligible resistance. Two voltmeters, V_1 and V_2 , are connected as shown. What are the readings on V_1 and V_2 when the switch is open?

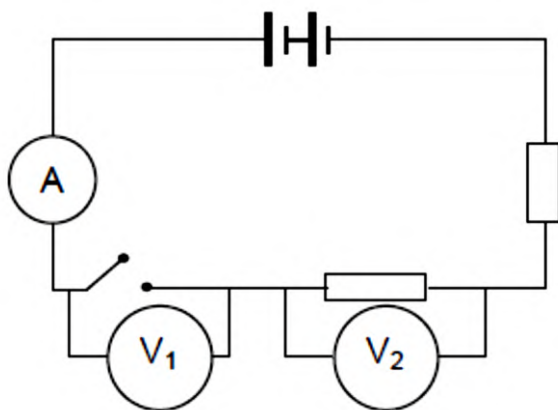

	V_1 (V)	V_2 (V)
A	12	12
B	0	12
C	12	0
D	0	0

(2)

[20]

SECTION B

QUESTION 2

- 2.1 A toy trailer, mass 3 kg, is connected to a toy car, mass 5 kg, by means of a light, inelastic string. A horizontal force of 40 N is then applied to the car and the velocity of the car and trailer increase uniformly in a straight line to the right. Both vehicles experience frictional forces while they are moving. The frictional force on the car has a magnitude of 4,9 N.

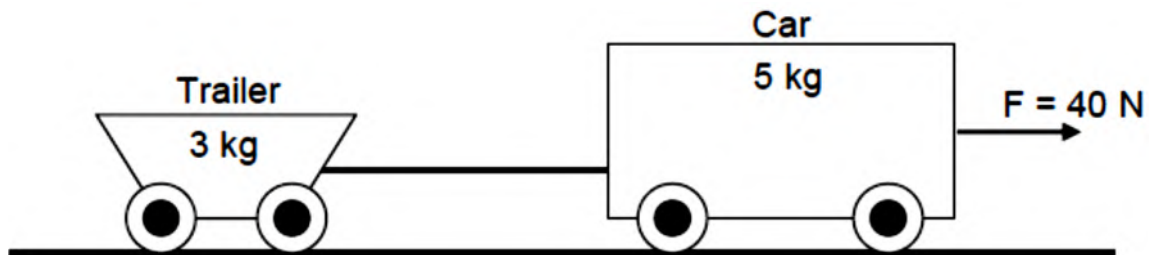

- 2.1.1 Write down *Newton's second law of motion* in words. (2)
- 2.1.2 What type of frictional force do the vehicles experience? (1)
- 2.1.3 Show by means of a calculation that the frictional force on the trailer has a magnitude of 2,94 N if the coefficient of friction is 0,1. (2)
- 2.1.4 Calculate the magnitude of the acceleration of the system. Write down separate equations for the two moving objects using Newton's second law of motion and then calculate the acceleration. (5)
- 2.1.5 Calculate the force exerted by the string ON THE CAR. (3)

The string is disconnected from the car and reconnected at a higher point to make an angle θ with the horizontal. The horizontal force of 40 N is again applied to the car to accelerate the system from rest as before.

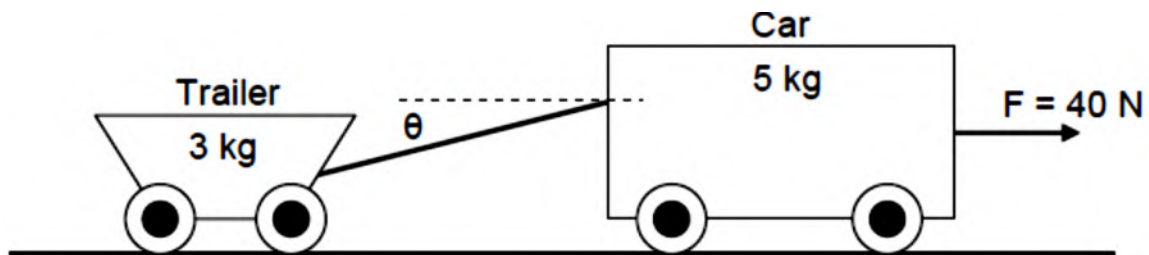

2.1.6 Draw a free-body diagram, with labels, of all the forces acting on the CAR. (5)

With the string in the new position, is the frictional force on the ...

2.1.7 trailer greater than, the same as or less than 2,94 N? (1)

2.1.8 car greater than, the same as or less than 4,9 N? (1)

2.2 The planet Mars has an approximate mass and radius of $6,39 \times 10^{23}$ kg and $3,39 \times 10^3$ km respectively. Calculate the approximate magnitude of the gravitational acceleration on the surface of Mars. (4)

[25]

QUESTION 3

A boy mass 60 kg on roller-skates, holds an iron rod of mass 2 kg in his hands. He is moving **forward** on a frictionless, horizontal surface at a speed of $1,5 \text{ m}\cdot\text{s}^{-1}$. In order to slow himself down, he throws the iron rod **horizontally away** from himself, in the **forward** direction, at a speed of $4 \text{ m}\cdot\text{s}^{-1}$. Ignore the effects of all types of friction.

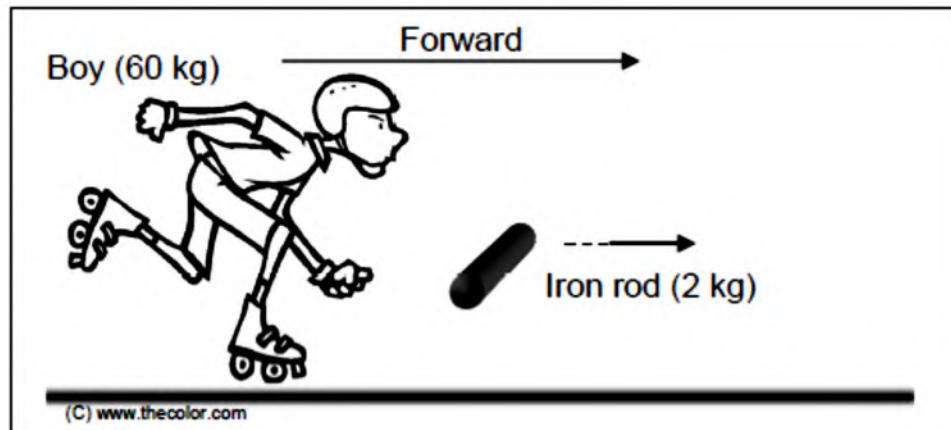

- 3.1 State in words, the *principle of conservation of linear momentum*. (2)
- 3.2 Calculate the boy's velocity immediately after he has thrown the iron rod. (5)
- 3.3 Will the boy's speed, under the following conditions, BE LESS THAN, THE SAME AS or GREATER THAN the answer calculated in QUESTION 3.2?
- 3.3.1 He throws the iron rod forward, but at a speed of LESS than $4 \text{ m}\cdot\text{s}^{-1}$. (1)
- 3.3.2 He throws the iron rod VERTICAL UPWARDS at a speed of $4 \text{ m}\cdot\text{s}^{-1}$. (1)

[9]

QUESTION 4

- 4.1 A player throws a cricket ball vertical upwards with an initial speed of $4,5 \text{ m}\cdot\text{s}^{-1}$ and catches it again at the same height from where it was projected. The table below shows the velocity of the ball at different times during the interval $t = 0 \text{ s}$ to $t = 2,5 \text{ s}$. UPWARD is taken as the POSITIVE DIRECTION.

Time (s)	0	0,5	1,0	1,5	2,0	2,5
Velocity ($\text{m}\cdot\text{s}^{-1}$)	14,5	10,0	4,0	-0,5	-5,5	-10,5

- 4.1.1 Use the tabulated data to draw a velocity-time graph of the ball's motion. Use the graph paper that is provided at the end of this question paper. Plot the points and draw the BEST-FIT graph (5)
- 4.1.2 Use THE GRAPH to calculate the displacement of the ball from $t = 1,5 \text{ s}$ to $t = 2,5 \text{ s}$. EQUATIONS OF MOTION MAY NOT BE USED. (4)
- 4.1.3 Under which condition can you consider the cricket ball to be a projectile? (1)
- 4.2 A ball with a mass of $0,5 \text{ kg}$ is fired vertical upwards from a platform, which is 14 m above the ground. The ball leaves at an initial speed of $40 \text{ m}\cdot\text{s}^{-1}$, at a height of 1 m above the platform. Ignore air resistance.
- 4.2.1 Calculate the maximum height the cannonball reaches above the ground. (5)
- 4.2.2 Calculate how long it takes to reach the maximum height. (3)
- 4.2.3 The total time elapsed from launching until it hits the ground can be calculated with the equation $\Delta y = v_i \Delta t + \frac{1}{2} a \Delta t^2$.
Use THIS EQUATION ONLY (NO OTHER ONE IN ADDITION TO THIS) and substitute the relevant values in order to determine the time. It is not necessary to solve the equation; just show the equation and the substitutions. (3)

[23]

QUESTION 5

- 5.1 A 0,20 kg rocket in a fireworks display is launched from rest from the ground and follows a straight flight path to reach point **P**, as shown in the figure below. Point **P** is 29 m above the starting point. In the process, 425 J of work is done on the rocket by the NON-CONSERVATIVE force generated by the burning propellant. Ignore air resistance and the mass lost due to the burning propellant.

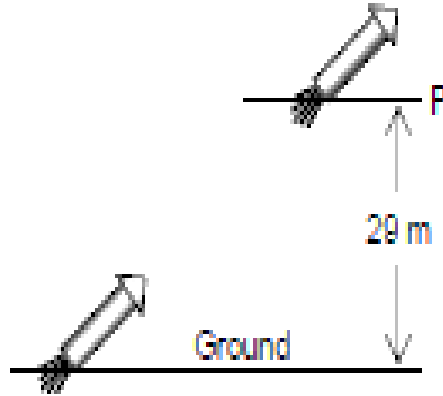

- 5.1.1 Explain what a *non-conservative* force is. (2)
- 5.1.2 Calculate the speed of the rocket at point **P**. (6)
- 5.2 A constant force **F** is applied to a crate to move it upwards along a frictionless, inclined plane. Force **F** is parallel to the inclined plane and the mass of the crate is 25 kg. When the crate reaches point **Q**, it's speed is $12 \text{ m}\cdot\text{s}^{-1}$, and $10,8 \text{ m}\cdot\text{s}^{-1}$ when it reaches point **R**, which is 3,5 m further up the incline. The incline makes an angle $\alpha = 30^\circ$ with the horizontal.

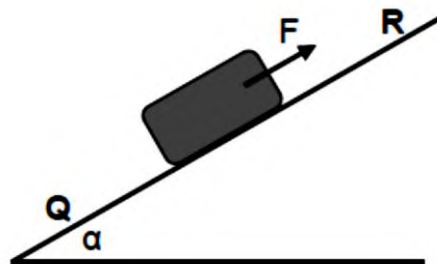

- 5.2.1 Draw a free-body diagram, with labels, of the forces acting on the crate while it is moving. (3)
- 5.2.2 State the WORK – ENERGY THEOREM in words (2)
- 5.2.3 Is mechanical energy conserved during this motion? Write down YES or NO and briefly explain your answer. (2)

5.2.4 Give a reason why the normal force does not do any work on the crate during its motion. (1)

5.2.5 Use ENERGY PRINCIPLES to calculate the magnitude of force F . (6)

[21]

QUESTION 6

The speed of sound in air depends among others on the air temperature. The following graph shows this relationship.

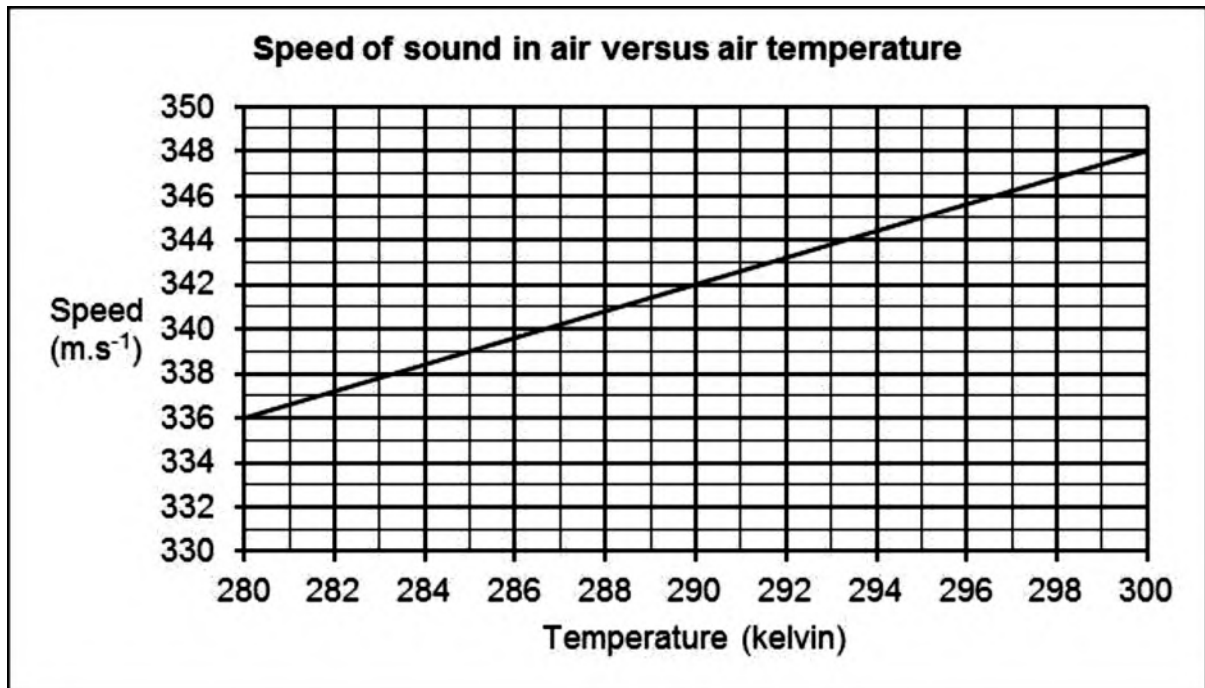

6.1 Which one of temperature or speed is the dependent variable? (1)

6.2 The gradient of this graph is equal to $0,6 \text{ m}\cdot\text{s}^{-1}\cdot\text{K}^{-1}$. With how much does the speed, in $\text{m}\cdot\text{s}^{-1}$, increase for every 5 K increase in temperature? (1)

6.3 Two experiments are done to verify the Doppler effect. In the first experiment, an object approaches a stationary observer **X** at a constant speed of $57,5 \text{ m}\cdot\text{s}^{-1}$. The object is equipped with a siren that emits sound waves at a fixed frequency of 1 000 Hz. The motion takes place in still air at a temperature of 295 K.

6.3.1 State *Doppler Effect* in words. (2)

6.3.2 What is the speed of sound, in $\text{m}\cdot\text{s}^{-1}$, in air at 295 K?
HINT: Use the graph (1)

6.3.3 Calculate the frequency measured by observer **X**. (5)

6.3.4 In the second experiment, the object moves away from observer **X** at the same constant speed as before. What should the air temperature, in kelvin, be to make it a fair test between the two experiments? (1)

6.4 Consider the three diagrams below. Each one represents the source (with the siren) and observer **X**. Two of the diagrams are applicable on the abovementioned experiments.

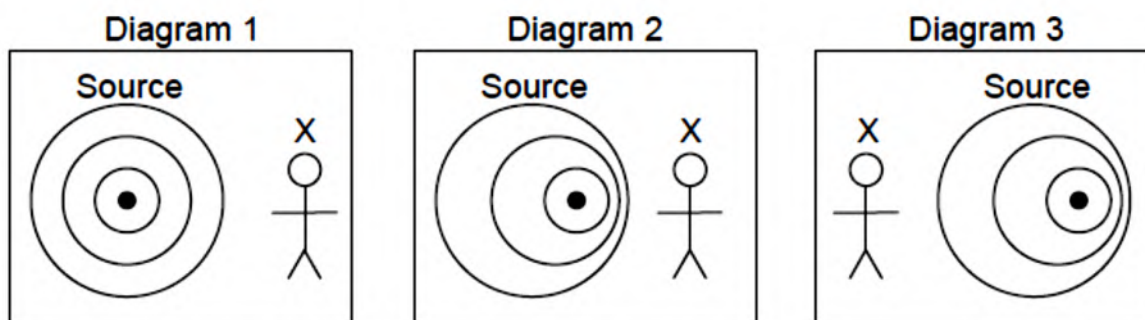

6.4.1 Which diagram is applicable to experiment 2? (1)

6.4.2 Which diagram is NOT applicable to any of the experiments? Give a reason for your answer. (2)

[13]

QUESTION 7

Two identical, small, metallic spheres, **P** and **R**, carry electric charges of $-20\ \mu\text{C}$ and $+30\ \mu\text{C}$ respectively. They are placed on the east-west axis of a compass as shown in the diagram below.

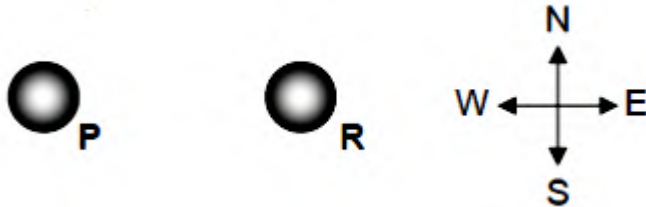

7.1 Define *electric field at a point* in words. (2)

7.2 Draw an electric field pattern for the two charges, **P** and **Q**. (3)

The centre of **P** is 7 cm from the centre of **R**. A third identical sphere, **Q**, is then placed as shown below, with its centre 9 cm away from the centre of **P**. **P** and **Q** are placed on the north-south axis of a compass and **Q** carries a charge of $-45\ \mu\text{C}$.

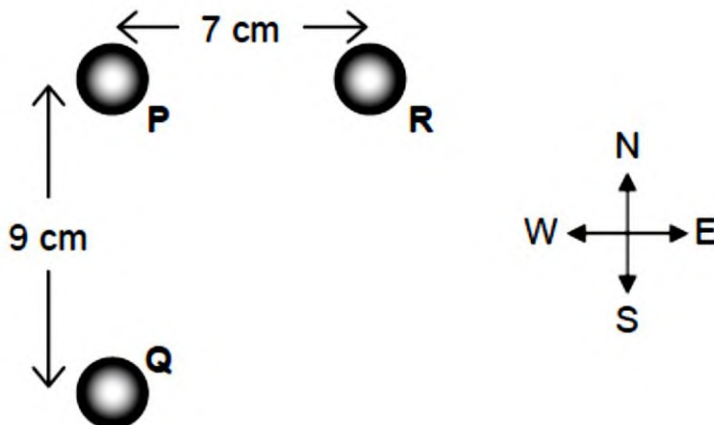

7.3 State *Coulomb's law* in words. (2)

7.4 Draw a free-body diagram, with labels, of all the electrostatic forces acting on **P** as a result of **Q** and **R**. (2)

7.5 Calculate the net electrostatic force experienced by **P** as a result of **Q** and **R**. (8)

[17]

QUESTION 8

A learner wants to use a 12 V battery, with negligible internal resistance, to operate a bulb. He uses the circuit below to obtain the desired potential difference for the bulb to glow. The resistance of the bulb is $5\ \Omega$. When switch **S** is closed as shown, the bulb glows at its **MAXIMUM POWER** of 5 W.

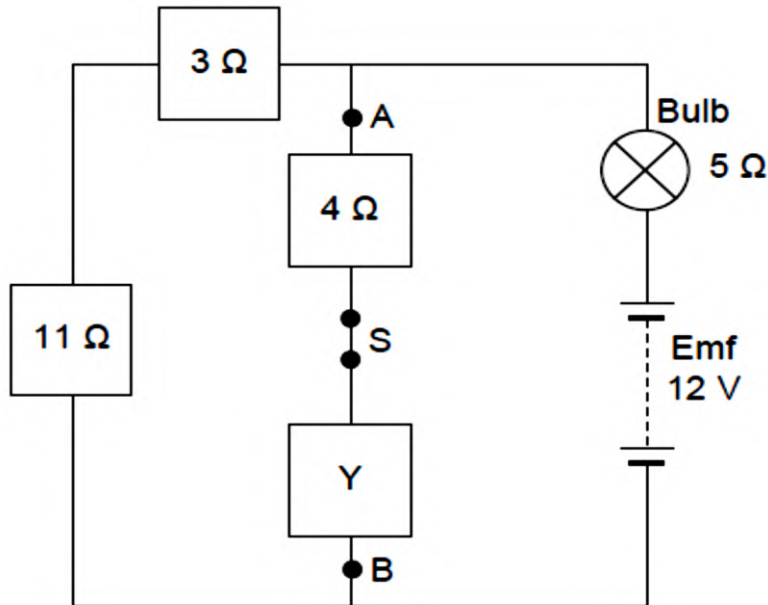

- 8.1 Explain in words what it means if the battery has an *emf* of 12 V. Refer to energy and charge, with relevant values, in your answer. (2)
- 8.2 State Ohm's Law in words (2)
- 8.3 Calculate the current in the bulb. (3)
- 8.4 Calculate the resistance of resistor **Y**. (7)
- 8.5 Calculate the cost to operate the bulb for a period of 1 400 minutes if one unit of electricity (1 kWh) costs R1,80. (3)
- 8.6 Switch **S** is now OPENED.
- 8.6.1 Will the bulb still function at maximum power? Write down either YES or NO and explain your answer without doing any calculations. (4)
- 8.6.2 How does the potential difference across **A** and **B** compare with its value when switch **S** was closed? Choose your answer from GREATER THAN, LESS THAN, EQUAL TO or ZERO. (2)

[23]

[150]

DATA FOR PHYSICAL SCIENCES GRADE 12

PAPER 1 (PHYSICS)

GEGEWENS VIR FISIESTE WETENSAPPE GRAAD 12

VRAESTEL 1 (FISIKA)

TABLE 1: PHYSICAL CONSTANTS / TABEL 1: FISIESTE KONSTANTES

NAME / NAAM	SYMBOL / SIMBOOL	VALUE / WAARDE
Acceleration due to gravity <i>Swaartekragversnelling</i>	g	$9,8 \text{ m}\cdot\text{s}^{-2}$
Universal gravitational constant <i>Universele gravitasiekonstante</i>	G	$6,67 \times 10^{-11} \text{ N}\cdot\text{m}^2\cdot\text{kg}^{-2}$
Speed of light in a vacuum <i>Spoed van lig in 'n vakuum</i>	c	$3,0 \times 10^8 \text{ m}\cdot\text{s}^{-1}$
Planck's constant <i>Planck se konstante</i>	h	$6,63 \times 10^{-34} \text{ J}\cdot\text{s}$
Coulomb's constant <i>Coulomb se konstante</i>	k	$9,0 \times 10^9 \text{ N}\cdot\text{m}^2\cdot\text{C}^{-2}$
Charge on electron <i>Lading op electron</i>	e^-	$-1,6 \times 10^{-19} \text{ C}$
Electron mass <i>Elektronmassa</i>	m_e	$9,11 \times 10^{-31} \text{ kg}$
Mass of Earth <i>Massa van Aarde</i>	M	$5,98 \times 10^{24} \text{ kg}$
Radius of Earth <i>Radius van Aarde</i>	R_E	$6,38 \times 10^6 \text{ m}$

TABLE 2: FORMULAE / TABEL 2: FORMULES

MOTION / BEWEGING

$v_f = v_i + a \Delta t$	$\Delta x = v_i \Delta t + \frac{1}{2} a \Delta t^2$ or/of $\Delta y = v_i \Delta t + \frac{1}{2} a \Delta t^2$
$v_f^2 = v_i^2 + 2a\Delta x$ or/of $v_f^2 = v_i^2 + 2a\Delta y$	$\Delta x = \left(\frac{v_i + v_f}{2} \right) \Delta t$ or/of $\Delta y = \left(\frac{v_i + v_f}{2} \right) \Delta t$

FORCE / KRAAG

$F_{\text{net}} = ma$	$p = mv$
$f_{s(\text{max})} = \mu_s N$	$f_k = \mu_k N$
$F_{\text{net}} \Delta t = \Delta p$ $\Delta p = mv_f - mv_i$	$w = mg$
$F = \frac{Gm_1 m_2}{r^2}$	$g = \frac{Gm}{r^2}$

WORK, ENERGY AND POWER / ARBEID, ENERGIE EN DRYWING

$W = F \Delta x \cos \theta$	$U = mgh$ or/of $E_p = mgh$
$K = \frac{1}{2} mv^2$ or/of $E_k = \frac{1}{2} mv^2$	$W_{\text{net}} = \Delta K$ or/of $W_{\text{net}} = \Delta E_k$ $\Delta K = K_f - K_i$ or/of $\Delta E_k = E_{kf} - E_{ki}$
$W_{\text{nc}} = \Delta K + \Delta U$ or/of $W_{\text{nc}} = \Delta E_k + \Delta E_p$	$P = \frac{W}{\Delta t}$
$P_{\text{av}} = F \cdot v_{\text{av}} / P_{\text{gem}} = F \cdot v_{\text{gem}}$	

WAVES, SOUND AND LIGHT / GOLWE, KLANK EN LIG

$v = f \lambda$	$T = \frac{1}{f}$
$f_L = \frac{v \pm v_L}{v \pm v_s} f_s$	$E = hf$ or/of $E = h \frac{c}{\lambda}$

$$E = W_0 + E_{k(\max)} \text{ or/of } E = W_0 + K_{(\max)} \quad \text{where/waar}$$

$$E = hf \quad \text{and/en} \quad W_0 = hf_0 \quad \text{and/en} \quad E_{k(\max)} = \frac{1}{2}mv_{\max}^2 \quad \text{or/of} \quad K_{(\max)} = \frac{1}{2}mv_{\max}^2$$

ELECTROSTATICS / ELEKTROSTATIKA

$F = \frac{kQ_1Q_2}{r^2}$	$E = \frac{kQ}{r^2}$
$V = \frac{W}{q}$	$E = \frac{F}{q}$
$n = \frac{Q}{e} \quad \text{OR/OF} \quad n = \frac{Q}{q_e}$	

ELECTRIC CIRCUITS / ELEKTRIESE STROOMBANE

$R = \frac{V}{I}$	emf (\mathcal{E}) = I (R + r) emk (\mathcal{E}) = I(R + r)
$R_s = R_1 + R_2 + \dots$ $\frac{1}{R_p} = \frac{1}{R_1} + \frac{1}{R_2} + \dots$	$q = I \Delta t$
$W = Vq$ $W = VI \Delta t$ $W = I^2 R \Delta t$ $W = \frac{V^2 \Delta t}{R}$	$P = \frac{W}{\Delta t}$ $P = VI$ $P = I^2 R$ $P = \frac{V^2}{R}$

ALTERNATING CURRENT / WISSELSTROOM

$I_{rms} = \frac{I_{max}}{\sqrt{2}} \quad / \quad I_{wgk} = \frac{I_{maks}}{\sqrt{2}}$	$P_{ave} = V_{rms} I_{rms} \quad / \quad P_{gemiddeld} = V_{wgk} I_{wgk}$
$V_{rms} = \frac{V_{max}}{\sqrt{2}} \quad / \quad V_{wgk} = \frac{V_{maks}}{\sqrt{2}}$	$P_{ave} = I_{rms}^2 R \quad / \quad P_{gemiddeld} = I_{wgk}^2 R$
	$P_{ave} = \frac{V_{rms}^2}{R} \quad / \quad P_{gemiddeld} = \frac{V_{wgk}^2}{R}$



education

Department:
Education
PROVINCE OF KWAZULU-NATAL

**NATIONAL
SENIOR CERTIFICATE**

GRADE 12

PHYSICAL SCIENCES P1 (PHYSICS)

MARKING GUIDELINE

HALF - YEARLY EXAMINATIONS

JUNE 2020

SECTION A

QUESTION 1: MULTIPLE-CHOICE QUESTIONS

- 1.1 A ✓✓ (2)
- 1.2 A ✓✓ (2)
- 1.3 B ✓✓ (2)
- 1.4 C ✓✓ (2)
- 1.5 D ✓✓ (2)
- 1.6 C ✓✓ (2)
- 1.7 B ✓✓ (2)
- 1.8 D ✓✓ (2)
- 1.9 D ✓✓ (2)
- 1.10 C ✓✓ (2)

[20]

SECTION B

QUESTION 2

- 2.1.1 When a resultant/net force acts on an object, the object will accelerate in the direction of the force at an acceleration directly proportional to the force and inversely proportional to the mass of the object. ✓✓

OR

The resultant/net force acting on an object is equal to the rate of change of momentum of the object in the direction of the resultant/net force. ✓✓ (2)

- 2.1.2 Kinetic (friction) ✓ (1)

- 2.1.3 $f_3 = \mu N$ ✓
 $= \mu mg$
 $= (0,1)(3)(9,8)$ ✓
 $= 2,94 \text{ N}$ (2)

2.1.4 **OPTION 1**
Right: Positive

$$\begin{aligned} \text{Trailer: } F_{\text{net}} &= ma \checkmark \\ T + f_3 &= ma \\ \underline{T - 2,94} \checkmark &= 3a \end{aligned}$$

$$\begin{aligned} \text{Car: } F_{\text{net}} &= ma \\ F + f_5 + T &= ma \\ \underline{40 - 4,9 - T} \checkmark &= 5a \\ a &= 4,02 \text{ m}\cdot\text{s}^{-2} \checkmark \end{aligned}$$

OPTION 2
Right: Negative

$$\begin{aligned} \text{Trailer: } F_{\text{net}} &= ma \checkmark \\ T + f_3 &= ma \\ -T + 2,94 \checkmark &= -3a \end{aligned}$$

$$\begin{aligned} \text{Car: } F_{\text{net}} &= ma \\ F + f_5 + T &= ma \\ \underline{-40 + 4,9 + T} \checkmark &= -5a \\ a &= 4,02 \text{ m}\cdot\text{s}^{-2} \checkmark \end{aligned}$$

OPTION 3
Right Positive

SYSTEM METHOD

$$\begin{aligned} F_{\text{net}} &= ma \checkmark \\ F + f_5 + f_3 &= ma \\ 40 - 4,9 - 2,94 &= 8a \checkmark \\ a &= 4,02 \text{ m}\cdot\text{s}^{-2} \checkmark \end{aligned}$$

Max:3/5

(5)

2.1.5 **POSITIVE MARKING FROM 2.1.4**

OPTION 1 (Car)
Right Positive

$$\begin{aligned} F_{\text{net}} &= ma \\ F + f_5 + F_T &= ma \\ \underline{40 + (-4,9) + F_T} &= 5(4,02) \checkmark \\ F_T &= -15 \text{ N} \\ F_T &= 15 \text{ N} \checkmark; \text{ left } \checkmark \end{aligned}$$

OPTION 1 (Car)
Right Positive

$$\begin{aligned} F_{\text{net}} &= ma \\ F + f_5 + F_T &= ma \\ \underline{-40 + 4,9 + F_T} &= 5(-4,02) \checkmark \\ F_T &= 15 \text{ N} \\ F_T &= 15 \text{ N} \checkmark; \text{ left } \checkmark \end{aligned}$$

OPTION 3 (Trailer)
Right Positive

$$\begin{aligned} F_{\text{net}} &= ma \\ f_3 + F_T &= ma \\ \underline{-2,94 + F_T} &= 3(4,02) \checkmark \\ F_T &= 15 \text{ N} \\ F_T \text{ on car} &= 15 \text{ N} \checkmark; \text{ left } \checkmark \end{aligned}$$

OPTION 4 (Trailer)
Right Negative

$$\begin{aligned} F_{\text{net}} &= ma \\ f_3 + F_T &= ma \\ \underline{2,94 - F_T} &= 3(-4,02) \checkmark \\ F_T &= 15 \text{ N} \\ F_T \text{ on car} &= 15 \text{ N} \checkmark; \text{ left } \checkmark \end{aligned}$$

(3)

2.1.6

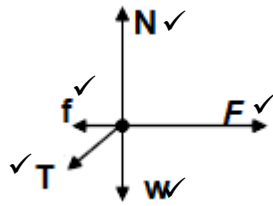

	Acceptable Symbols
N	F_{Normal}, F_N
T	Tension, F_T, F_{tension}
f	$F_f, f_k, F_{\text{friction}}$
w	F_g, F_{gravity}
F	F_{app}

(5)

2.1.7 Less than ✓✓

(2)

2.1.8 Greater than ✓✓

(2)

2.2

$$g \equiv G \frac{M}{r^2} \checkmark$$

$$g = 6,67 \times 10^{-11} \frac{6,39 \times 10^{23}}{(3,39 \times 10^6)^2} \checkmark$$

$$g = 3,71 \text{ m}\cdot\text{s}^{-2} \checkmark$$

(4)

[25]

QUESTION 3

3.1 The total linear momentum of a closed system remains constant (is conserved). ✓✓

(2)

3.2 **OPTION 1**
Right Positive

$$\Sigma p_f = \Sigma p_i$$

$$m_1 v_1 + m_2 v_2 = (m_1 + m_2) v \checkmark$$

$$60 v_f + 2(4) \checkmark = 62(1,5) \checkmark$$

$$v_f = 1,42 \text{ m}\cdot\text{s}^{-1}$$

$v_f = 1,42 \text{ m}\cdot\text{s}^{-1} \checkmark$; forward / to the right ✓

OPTION 1
Right Negative

$$\Sigma p_f = \Sigma p_i$$

$$m_1 v_1 + m_2 v_2 = (m_1 + m_2) v \checkmark$$

$$60 v_f + 2(-4) \checkmark = 62(-1,5) \checkmark$$

$$v_f = -1,42 \text{ m}\cdot\text{s}^{-1}$$

$v_f = 1,42 \text{ m}\cdot\text{s}^{-1} \checkmark$; forward / to the right ✓

OPTION 3

Right Positive

$$\Delta p_1 = -\Delta p_2 \quad \curvearrowright \checkmark$$

$$m_1 \Delta v_1 = -m_2 \Delta v_2$$

$$60(v_f - 1,5) \checkmark = -2(4 - 1,5) \checkmark$$

$$v_f = 1,42 \text{ m}\cdot\text{s}^{-1}$$

$v_f = 1,42 \text{ m}\cdot\text{s}^{-1} \checkmark$; forward / to the right \checkmark

OPTION 3

Right Negative

$$\Delta p_1 = -\Delta p_2 \quad \curvearrowright \checkmark$$

$$m_1 \Delta v_1 = -m_2 \Delta v_2$$

$$60[v_f - (-1,5)] \checkmark = -2[-4 - (-1,5)] \checkmark$$

$$v_f = -1,42 \text{ m}\cdot\text{s}^{-1}$$

$v_f = 1,42 \text{ m}\cdot\text{s}^{-1} \checkmark$; forward / to the right \checkmark

(5)

3.3.1 Greater than \checkmark

(1)

3.3.2 Greater than \checkmark

(1)

[9]

QUESTION 4

4.1.1

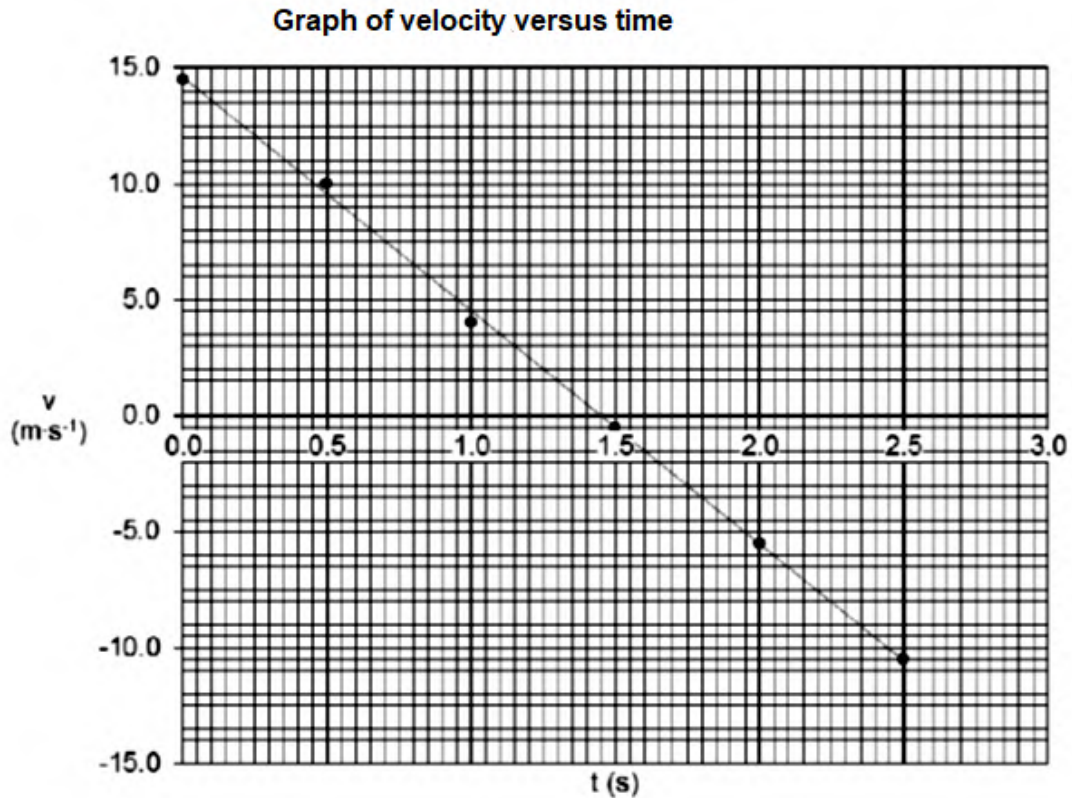

Marking criteria

- Any first point plotted correctly ✓
- Any second point plotted correctly ✓
- Any third and fourth points plotted correctly ✓
- Any fifth and six points plotted correctly ✓
- Best-fit line drawn ✓

(5)

4.1.2 **Positive marking from 4.1.1**

For triangle+rectangle

$$\Delta y = \frac{1}{2}bh + \ell \times w \quad \checkmark \quad (\text{or similar})$$

$$= \frac{1}{2}(1)(-10) \checkmark + (1)(-0,5) \checkmark$$

$$= -5,5 \text{ m}$$

$$\Delta y = 5,5 \text{ m} \checkmark; \text{ downwards } \checkmark$$

For trapezium

$$\Delta y = \frac{1}{2}(\Sigma //)\Delta t \quad \checkmark \quad (\text{or similar})$$

$$= \frac{1}{2}[-0,5 + (-10,5)] \checkmark \times (1) \checkmark$$

$$= -5,5 \text{ m}$$

$$\Delta y = 5,5 \text{ m} \checkmark; \text{ downwards } \checkmark$$

(5)

4.1.3 When the only force acting on it is the force of gravity. ✓

(1)

4.2.1 **OPTION 1**
UPWARDS: POSITIVE
 $v_f^2 = v_i^2 + 2a\Delta y \checkmark$
 $0^2 \checkmark = 40^2 + 2(-9,8)\Delta y \checkmark$
 $\Delta y = 81,6327 \text{ m}$
 Height = 81,63 + \checkmark 15
 = 96,63 m \checkmark

OPTION 2
UPWARDS: NEGATIVE
 $v_f^2 = v_i^2 + 2a\Delta y \checkmark$
 $0^2 \checkmark = -40^2 + 2(9,8)\Delta y \checkmark$
 $\Delta y = -81,6327 \text{ m}$
 Height = 81,63 + \checkmark 15
 = 96,63 m \checkmark

(5)

4.2.2 **OPTION 1**
UPWARDS: POSITIVE
 $v_f = v_i + a\Delta t \checkmark$
 $0 = 40 + (-9,8)\Delta t \checkmark$
 $\Delta t = 4,08 \text{ s} \checkmark$

OPTION 2
UPWARDS: NEGATIVE
 $v_f = v_i + a\Delta t \checkmark$
 $0 = -40 + (9,8)\Delta t \checkmark$
 $\Delta t = 4,08 \text{ s} \checkmark$

(3)

POSITIVE MARKING FROM 4.2.1

OPTION 3
UPWARDS: POSITIVE
 $\Delta y = v_i\Delta t + \frac{1}{2}a\Delta t^2 \checkmark$
 $81,63 = 40\Delta t + \frac{1}{2}(-9,8)\Delta t^2 \checkmark$
 $\Delta t = 4,08 \text{ s} \checkmark$

OPTION 4
UPWARDS: NEGATIVE
 $\Delta y = v_i\Delta t + \frac{1}{2}a\Delta t^2 \checkmark$
 $-81,63 = -40\Delta t + \frac{1}{2}(9,8)\Delta t^2 \checkmark$
 $\Delta t = 4,08 \text{ s} \checkmark$

OPTION 5
UPWARDS: POSITIVE
 $\Delta y = \left(\frac{v_i+v_f}{2}\right)\Delta t \checkmark$
 $81,63 = \left(\frac{40+0}{2}\right)\Delta t \checkmark$
 $\Delta t = 4,08 \text{ s} \checkmark$

OPTION 6
UPWARDS: NEGATIVE
 $\Delta y = \left(\frac{v_i+v_f}{2}\right)\Delta t \checkmark$
 $-81,63 = \left(\frac{-40+0}{2}\right)\Delta t \checkmark$
 $\Delta t = 4,08 \text{ s} \checkmark$

4.2.3 **OPTION 1**
UPWARDS: POSITIVE
 $\Delta y = v_i\Delta t + \frac{1}{2}a\Delta t^2$
 $-15 \checkmark = +40\Delta t \checkmark + \frac{1}{2}(-9,8)\Delta t^2 \checkmark$

OPTION 2
UPWARDS: NEGATIVE
 $\Delta y = v_i\Delta t + \frac{1}{2}a\Delta t^2$
 $15 \checkmark = -40\Delta t \checkmark + \frac{1}{2}(9,8)\Delta t^2 \checkmark$

(3)

QUESTION 5

5.1.1 A non-conservative force is a force for which the work done in moving an object between two points depends on the path taken. ✓✓ (2)

5.1.2

$$W_{\text{net}} = \Delta K$$

$$W_{\text{app}} + W_w = K_f - K_i$$

$$425 \checkmark + (0,20)(9,8)(29)(\cos 180^\circ) \checkmark = \frac{1}{2}(0,20)(v_p^2 - 0) \checkmark$$

$$v_p = 60,68 \text{ m}\cdot\text{s}^{-1} \checkmark$$

(5)

5.2.1

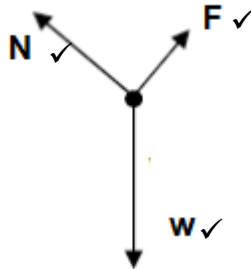

	Acceptable Symbols
N	F_N, F_{Normal}
w	F_g, F_{gravity}
F	F_{app}

(3)

5.2.2 The net/total work done on an object is equal to the change in the object's kinetic energy. ✓✓

OR

The work done on an object by a resultant/net force is equal to the change in the object's kinetic energy. ✓✓

(2)

5.2.3 No ✓

Weight is not the only force doing work on the crate. ✓

(2)

5.2.4 N is perpendicular to displacement. ✓ (1)

5.2.5 **OPTION 1**

$$W_{\text{net}} = \Delta K$$

$$W_F + W_N + W_w = K_f - K_i$$

$$F(3,5)\cos 0^\circ + 0 + [25 \times 9,8 \times 3,5 \sin 30^\circ \times \cos 180^\circ] = \frac{1}{2} \times 25 \times [10,8^2 - (12^2)]$$

$$F = 24,79 \text{ N}$$

(6)

[21]

QUESTION 6

6.1 Speed ✓ (1)

6.2 3 ✓ (m•s⁻¹) (1)

6.3.1 It is the change in frequency (or pitch) of the sound detected by a listener because the sound source and the listener have different velocities of propagation ✓✓ (2)

6.3.2 345 ✓ (m•s⁻¹) (1)

6.3.3 **POSITIVE MARKING FROM 6.3.2**

$$f_L = \frac{v + v_L}{v - v_S} f_S$$

$$f_L = \left(\frac{345 + 0}{345 - 57,5} \right) (1000)$$

$$f_L = 1200 \text{ Hz} \quad (5)$$

6.3.4 295 ✓ (K) Accept: The same temperature (1)

6.4.1 (Diagram) 3 ✓ (1)

6.4.2 1 ✓
The source is stationary. ✓ (2)

[14]

QUESTION 7

7.1 The electric field at a point is the electrostatic force experienced per unit positive charge placed at that point. ✓✓ (2)

7.2

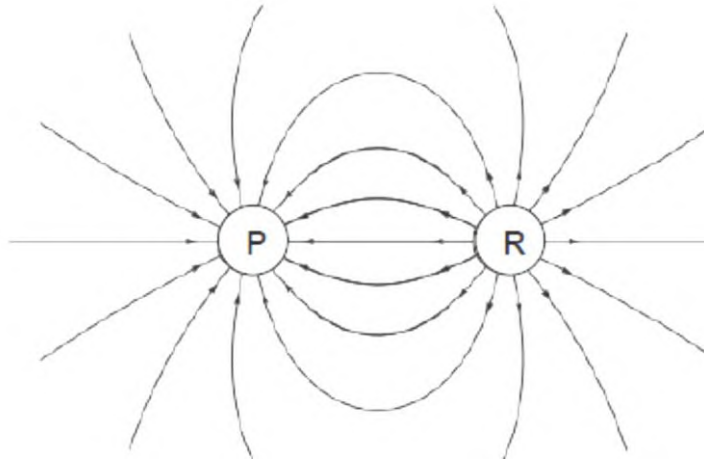

Marking criteria
 Pattern ✓
 Direction ✓
 Field lines must touch charges at 90°. ✓

7.3 The magnitude of the electrostatic forces exerted by two point charges on each other is directly proportional to the product of the magnitudes of the charges and inversely proportional to the square of the distance between them. ✓✓ (3)
 (2)

7.4

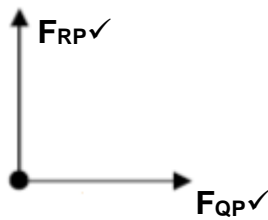

(2)

7.5 $F = k \frac{q_1 q_2}{r^2}$ ✓

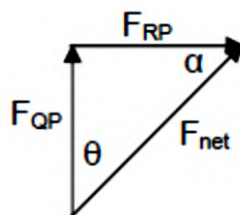

$$F_{QP} = 9 \times 10^9 \frac{45 \times 10^{-6} \times 20 \times 10^{-6}}{(0,09)^2} \checkmark = 1 \times 10^3 \text{ N}$$

$$F_{RP} = 9 \times 10^9 \frac{30 \times 10^{-6} \times 20 \times 10^{-6}}{(0,07)^2} \checkmark = 1,102 \times 10^3 \text{ N}$$

$$F_{\text{net}}^2 = F_{RP}^2 + F_{QP}^2 \checkmark$$

$$= (1,102 \times 10^3)^2 + (1 \times 10^3)^2 \checkmark$$

$$F_{\text{net}} = 1,49 \times 10^3 \text{ N} \checkmark$$

$$\theta = \tan^{-1}(1,102 \times 10^3 / 1 \times 10^3) \checkmark$$

$$= 47,78^\circ \checkmark$$

If α is used:

$$\alpha = \tan^{-1}(1 \times 10^3 / 1,102 \times 10^3) \checkmark$$

$$= 42,22^\circ \checkmark$$

Accept correct trigonometry if F_{net} and F_{QP} or F_{net} and F_{RP} are used.	(8)
---	-----

[17]

QUESTION 8

8.1 The battery can supply a maximum of 12 J of (electrical) energy to every 1 C of charge. $\checkmark\checkmark$ (2)

8.2 The potential difference across a conductor is directly proportional to the current in the conductor at constant temperature. $\checkmark\checkmark$ (2)

8.3	OPTION 1 $P = I^2 R \checkmark$ $5 = I^2(5) \checkmark$ $I = 1 \text{ A} \checkmark$	OPTION 2 $P = \frac{V^2}{R}$ $5 = \frac{V^2}{5}$ $V = 5 \text{ V}$ <hr style="border: none; border-top: 1px solid black; margin: 5px 0;"/> <table style="width: 100%; border-collapse: collapse;"> <tr> <td style="width: 50%; padding: 2px;">$P = VI \checkmark$</td> <td style="width: 50%; padding: 2px;">$V = IR \checkmark$</td> </tr> <tr> <td style="padding: 2px;">$5 = 5I \checkmark$</td> <td style="padding: 2px;">$5 = I \cdot 5 \checkmark$</td> </tr> <tr> <td style="padding: 2px;">$I = 1 \text{ A} \checkmark$</td> <td style="padding: 2px;">$I = 1 \text{ A} \checkmark$</td> </tr> </table>	$P = VI \checkmark$	$V = IR \checkmark$	$5 = 5I \checkmark$	$5 = I \cdot 5 \checkmark$	$I = 1 \text{ A} \checkmark$	$I = 1 \text{ A} \checkmark$
$P = VI \checkmark$	$V = IR \checkmark$							
$5 = 5I \checkmark$	$5 = I \cdot 5 \checkmark$							
$I = 1 \text{ A} \checkmark$	$I = 1 \text{ A} \checkmark$							

(3)

8.4

OPTION 1	OPTION 2
$V = I \times R_{\text{bulb}} \checkmark$	$E = I(R + r) \checkmark$
$V = 1 \times 5 \checkmark$	$12 = 1(R + 0) \checkmark$
$V = 5 \text{ V}$	$R = 12 \Omega$
$V_{//} = 12 - 5 = 7 \text{ V}$	$R_T = R_{\text{Bulb}} + R_{//}$
$V_{//} = I \times R_{(3+11)}$	$12 \checkmark = 5 \checkmark + R_{//}$
$7 \checkmark = I \times 14 \checkmark$	$R_{//} = 7 \Omega$
$I = 0,5 \text{ A}$	$\frac{1}{R_T} = \frac{1}{R_1} + \frac{1}{R_2}$
$I_{AB} = 1 - 0,5 = 0,5 \text{ A}$	$\frac{1}{R_{//}} = \frac{1}{R_{3+11}} + \frac{1}{R_{AB}}$
$R_{AB} = \frac{V_{//}}{I}$	$\frac{1}{7} \checkmark = \frac{1}{14} \checkmark + \frac{1}{R_{AB}}$
$R_{AB} = \frac{7 \checkmark}{0,5 \checkmark}$	$R_{AB} = 14 \Omega$
$R_{AB} = 14 \Omega$	$R_Y = 14 - 4 = 10 \Omega \checkmark$
$R_Y = 14 - 4 = 10 \Omega \checkmark$	

(7)

8.5 Cost = energy used x tariff per kWh
= Pt x tariff per kWh

$$\text{Cost} = \left(\frac{5}{1000}\right) \left(\frac{1400}{6}\right) \checkmark (180) \checkmark$$

$$\text{Cost} = R0,21 \checkmark$$

(3)

8.6.1 No \checkmark

- Total resistance increases. \checkmark
- Current through bulb/main current decreases. \checkmark
- According to $P = I^2R$ power decreases. \checkmark

(4)

8.6.2 Greater than \checkmark

(1)

[22]

[150]