



**GAUTENG PROVINCE**  
EDUCATION  
REPUBLIC OF SOUTH AFRICA

**GAUTENG DEPARTMENT OF EDUCATION  
PREPARATORY EXAMINATION  
2018**

**10841  
PHYSICAL SCIENCES: PHYSICS  
PAPER 1**

**TIME: 3 hours**

**MARKS: 150**

**15 pages + 4 data sheets**

PHYSICAL SCIENCES: Paper 1  
1084E



10841E

**X05**



**GAUTENG DEPARTMENT OF EDUCATION  
PREPARATORY EXAMINATION – 2018**

**PHYSICAL SCIENCES  
(Paper 1)**

**TIME: 3 hours**

**MARKS: 150**

---

---

**INSTRUCTIONS AND INFORMATION**

1. The question paper consists of 9 questions. Answer ALL the questions in the ANSWER BOOK.
2. Start each question on a NEW page in the ANSWER BOOK.
3. Number the answers correctly according to the numbering system used in this question paper.
4. Leave ONE line open between two sub-questions, for example between Question 2.1 and Question 2.2.
5. You may use a non-programmable calculator.
6. You may use appropriate mathematical instruments.
7. You are advised to use the attached DATA SHEETS.
8. Show ALL formulae and substitutions in ALL calculations.
9. Round-off your final numerical answers to a minimum of TWO decimal places.
10. Give brief motivations, discussions, et cetera where required.
11. Write neatly and legibly.

**QUESTION 1: MULTIPLE-CHOICE QUESTIONS**

Various options are provided as possible answers to the following questions. Choose the answer and write only the letter (A – D) of your choice next to the question number (1.1 – 1.10) in the ANSWER BOOK, e.g. 1.11 D.

1.1 Which one of the following physical quantities is equal to the product of net force and change in time?

- A Power
- B Impulse
- C Energy
- D Work

(2)

1.2 A full brick of mass  $m$  and a half brick of mass  $\frac{1}{2} m$  fall freely from the 10<sup>th</sup> floor of a building. Ignore the effects of air resistance.

When the bricks are  $4 m$  above the ground, they have the same ...

- A kinetic energy.
- B potential energy.
- C acceleration.
- D momentum.

(2)

1.3 A package is dropped from a hot air balloon from two different heights. In the first instance the height of the balloon from the ground is  $H$  and it takes  $t$  seconds for the package to reach the ground. In the second instance the package is dropped from a height of  $4H$ .

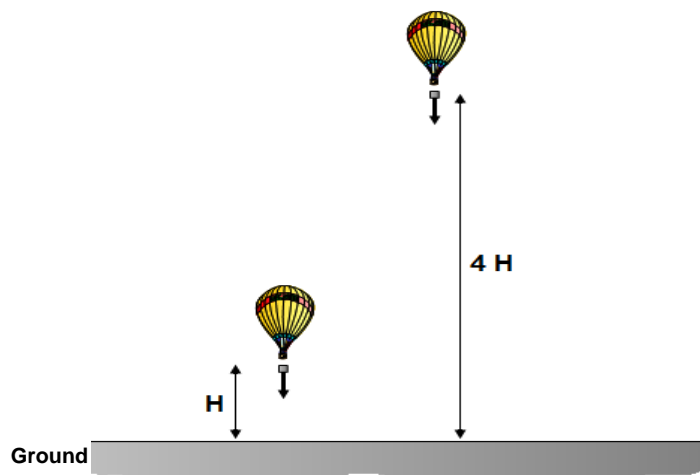

The time for the package, dropped from the height of  $4H$ , to reach the ground compared to the time  $t$  of the package dropped from  $H$  is:

- A  $t$
- B  $2t$
- C  $4t$
- D  $16t$

(2)

- 1.4 A ball is rolled up a smooth, inclined plane. The ball stops briefly at some point on its way up and rolls back to the point where it was first released.

Which one of the following velocity-time graphs best shows the motion of the ball?

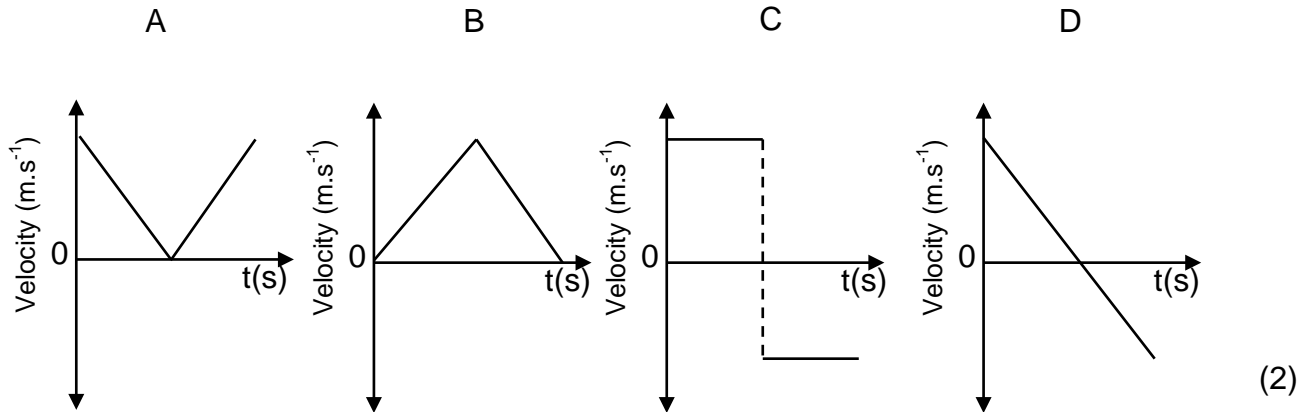

- 1.5 A passenger in a car that is moving at constant velocity at night observes that there is a car behind them through its lights and sound. If the passenger hears a higher frequency than that emitted by the engine of the car behind them then the car behind them is ...

- A moving at the same speed as theirs.
  - B moving faster than theirs.
  - C moving slower than theirs.
  - D stationary with its lights on and engine at a constant high rev.
- (2)

- 1.6 Two small, oppositely charged spheres on an insulated surface are held a distance  $r$  apart as shown in the diagram.

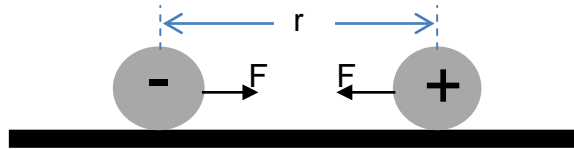

When the spheres are released simultaneously, they roll towards each other due to the electrostatic force of attraction.

Which ONE of the following graphs represents the magnitude of the force experienced by each sphere as a function of the distance  $r$  between their centres?

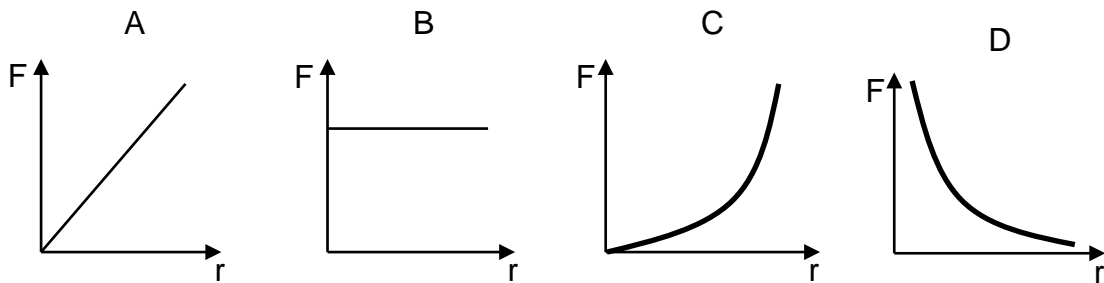

(2)

- 1.7 The free-body diagram below shows all the forces acting on an object that is moving up an inclined plane. All the forces are drawn to scale.

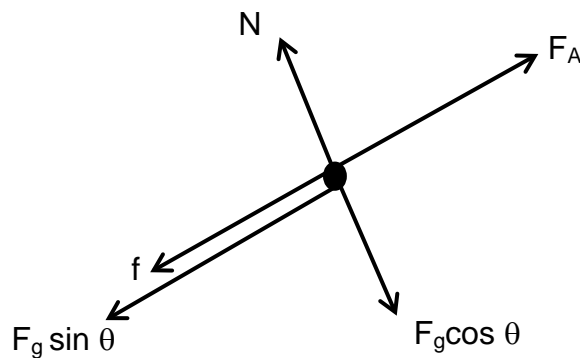

The **kinetic energy** of the object ....

- A increases.
- B decreases.
- C is zero.
- D remains the same.

(2)

- 1.8 A battery with an emf  $\mathcal{E}$  and an internal resistance  $r$  is connected to a resistor  $R$  as shown in the diagram below.

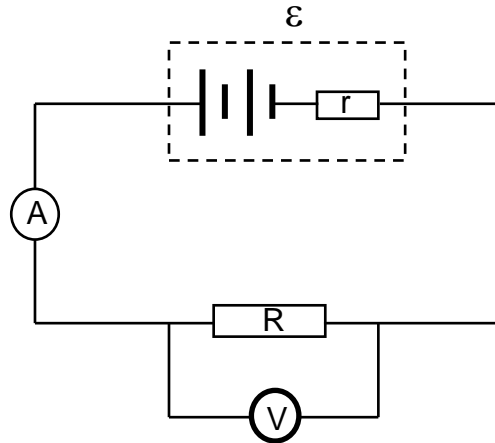

A second resistor with the **same resistance** as  $R$  is connected in parallel with  $R$ . How will the voltmeter and ammeter readings change when the second resistor is added to the circuit?

	Voltmeter reading	Ammeter reading
A	Increases	Increases
B	Decreases	Increases
C	Increases	Stays the same
D	Stays the same	Decreases

(2)

- 1.9 An experiment was carried out to study the effect of a magnetic field on a current carrying conductor **Y**, placed within a magnetic field. **X** and **Z** are poles of magnets.

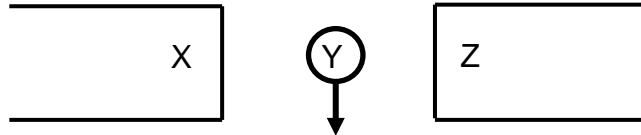

When a current flows through **Y**, the conductor moves downwards as shown by the arrow. Which one of the following combinations, regarding the **polarities** of the magnets and the direction of the current is correct?

	Polarity X	Polarity Z	Current direction in Y
A	South	North	Out of the page
B	North	North	Into the page
C	North	South	Out of the page
D	North	South	Into the page

(2)

- 1.10 Electron transitions occur in an atom as shown in the diagram. In each transition photons are emitted.

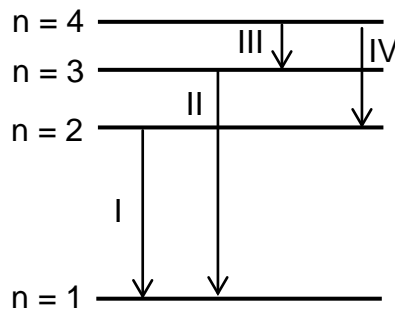

If the emitted photons are all capable of releasing photoelectrons from a certain metal, which photon will release electrons with the lowest kinetic energy?

- A I
- B II
- C III
- D IV

(2)  
[20]

**QUESTION 2 (Start on a new page.)**

A 50 kg stunt dummy is attached to one end of a 5 m inelastic light rope. The other end is attached to a fixed point **P** that is 5 m vertically above a stationary wagon. The dummy is then pulled upward to point **A** such that the rope is fully stretched and held horizontally as shown in the diagram below. When released, the dummy swings downwards along the dotted path. On reaching the stationary wagon, the stunt dummy detaches from the rope, falls flat on the wagon and sticks to it. The wagon has a mass of 60 kg.

The wagon and the stunt dummy move as one unit towards the right.

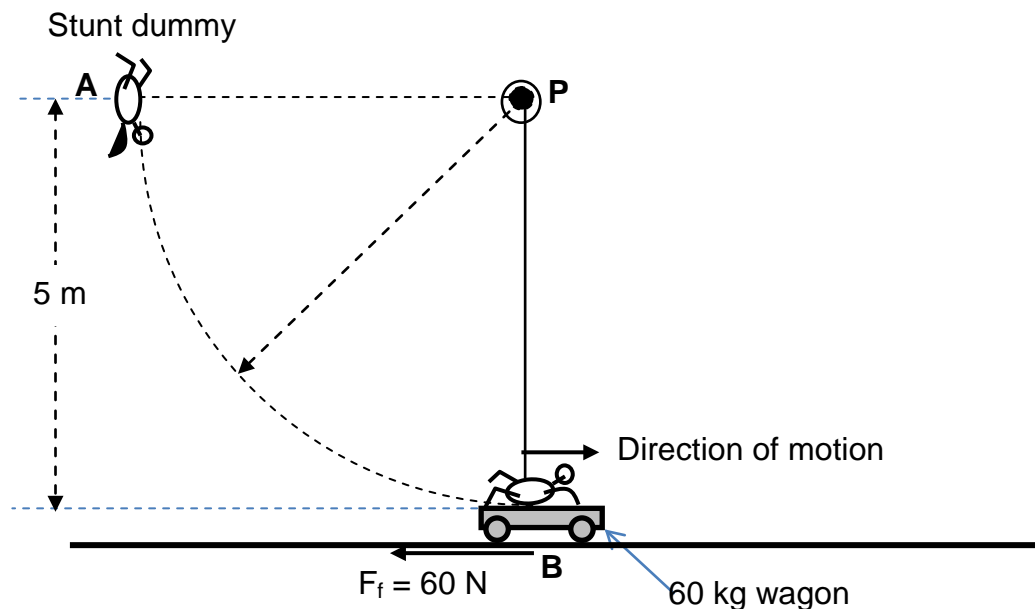

2.1 State the *law of conservation of mechanical energy*. (2)

2.2 Calculate the magnitude of the velocity of the stunt dummy when it reaches its lowest point **B**. (4)

As the dummy and the wagon move as one unit towards the right, a constant frictional force of 60 N acts on the wheels of the wagon as shown.

2.3 State the *principle of conservation of linear momentum*. (2)

2.4 Calculate the ...

2.4.1 initial velocity of the dummy and wagon soon after the dummy lands on the wagon. (3)

2.4.2 impulse provided to the dummy. (2)

2.4.3 distance moved by the dummy-and-wagon combination before coming to rest. (4)

[17]



**QUESTION 3 (Start on a new page.)**

1. A tennis ball is thrown with a velocity of  $10 \text{ m}\cdot\text{s}^{-1}$  vertically downwards from the top of a 20 m high building. The ball bounces off the ground, reaching a height which is 1 m below the point from which it was projected. Ignore air resistance and any lateral movement of the ball.

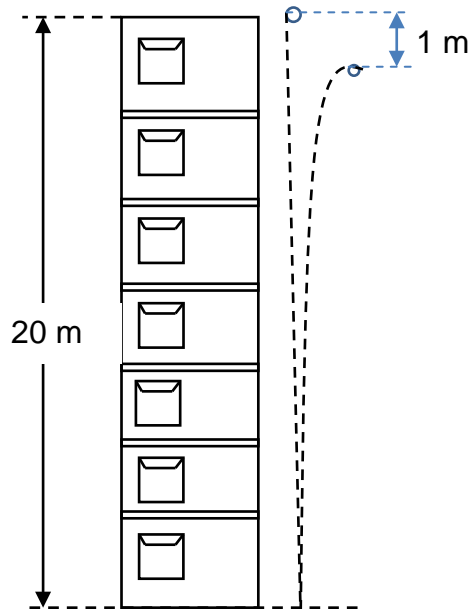

- 3.1 Explain *free fall*. (2)
- 3.2 Calculate the magnitude of the velocity with which the ball strikes the ground. (3)
- 3.3 Calculate the time that it takes the ball to reach the ground after it was thrown. (3)
- 3.4 Calculate the magnitude of the velocity with which the ball leaves the ground after the bounce. (3)
- 3.5 Is the collision of the ball with the ground elastic or inelastic?  
Give a reason for your answer. (2)
- 3.6 Sketch the *velocity-time graph* of the ball's flight from the moment it was thrown to the maximum height after the bounce. Your sketch must show values at the following points:
- Velocity when ball was thrown
  - Velocity just before it bounced off the ground
  - Velocity just after the bounce
  - Time after launch at which it bounced on the ground

(6)  
[19]

**QUESTION 4 (Start on a new page.)**

A 40 kg box slides from rest down a rough slope of length 8 m. It starts the downward slide from a height  $h$  above the horizontal. The slope makes an angle of  $30^\circ$  with the horizontal. While sliding, the box experiences a constant acceleration of  $2 \text{ m}\cdot\text{s}^{-2}$ .

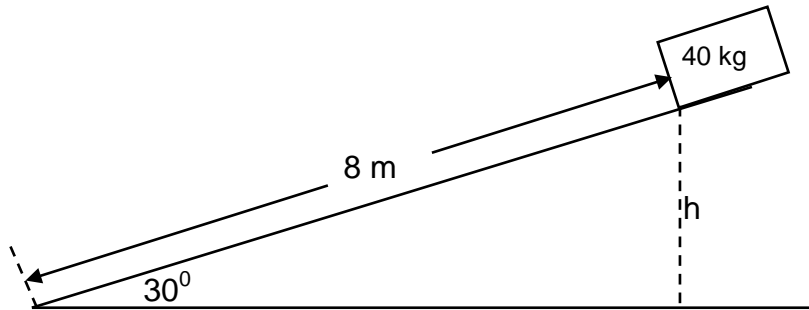

- 4.1 State the *Work-Energy theorem* in words. (2)
- 4.2 Draw a free-body diagram that shows ALL the forces acting on the box as it slides down the slope. (3)
- 4.3 Calculate the following:
- 4.3.1 The kinetic energy of the box as it reaches the bottom of the slope (5)
- 4.3.2 The work done on the box by the gravitational force (4)
- 4.3.3 The work done on the box by the frictional force **using the work-energy theorem** (4)
- 4.3.4 The magnitude of the frictional force acting on the box (3)
- [21]**

**QUESTION 5 (Start on a new page.)**

Two racing cars approach the finishing line as shown on the diagram below. Car **A** approaches the finishing line at a speed of  $284,4 \text{ km}\cdot\text{h}^{-1}$ . The engine of car **A** produces a sound with a frequency of  $1200 \text{ Hz}$ . Assume the speed of sound in air is  $340 \text{ m}\cdot\text{s}^{-1}$ .

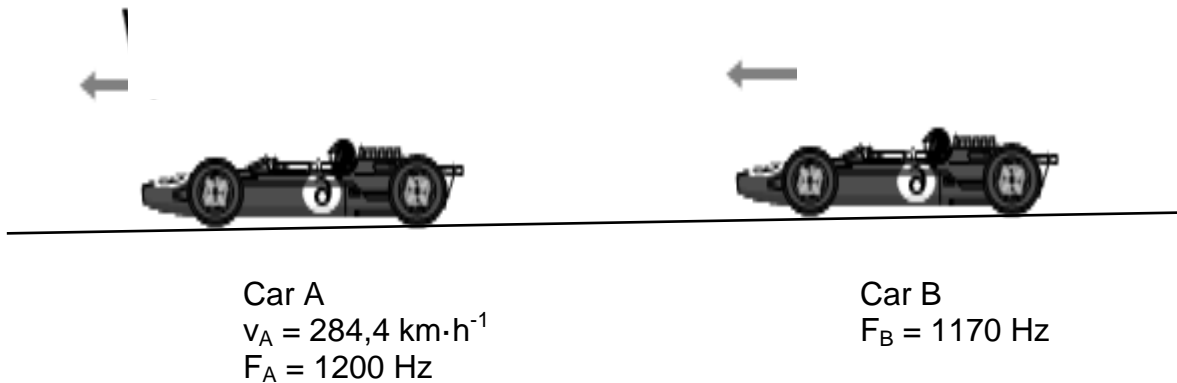

- 5.1 State the *Doppler effect*. (2)
- 5.2 For car **A**, what frequency of the engine sound will a man at the finishing line hear? (5)
- 5.3 A second racing car, **B**, produces a sound with a frequency of  $1170 \text{ Hz}$  which is heard by a man at the finishing line as  $1\ 600 \text{ Hz}$ .  
What is the speed of car **B**? (4)
- 5.4 An ambulance races towards an accident scene with its siren blaring and its red lights flashing.  
Explain why there is a noticeable change in the siren's frequency as the ambulance approaches an observer but there is no noticeable change in the colour of the red light. (4)

(4)  
[15]

**QUESTION 6 (Start on a new page.)**

Learners are provided with apparatus as shown in the diagram below to investigate the relationship between current ( $I$ ) flowing through a resistor and the potential difference ( $V$ ) across the resistor.



- 6.1 Write down the investigative question. (2)
- 6.2 Draw a circuit diagram to show how the learners must connect all the apparatus for a successful investigation. (3)
- 6.3 Identify:
- 6.3.1 The independent variable (1)
- 6.3.2 The dependent variable (1)
- 6.3.3 The variable that must be controlled (1)
- 6.4 Explain how you would go about controlling the variable mentioned in Question 6.3.3. (1)
- 6.5 The learners recorded the following readings of results of the investigation: At start, the voltmeter ( $V$ ) reads 0,00 when ammeter ( $A$ ) reads 0,00; when  $A$  is 0,29,  $V$  is 1; when  $A$  is 0,6,  $V$  is 2;  $A$  is 0,9 when  $V$  is 3; when  $A$  is 1,22,  $V$  is 4;  $A$  is 1,48 when  $V$  is 5.
- 6.5.1 Rewrite these results in a suitable table. (3)
- 6.5.2 Draw a fully-labelled graph of the results. (4)
- 6.5.3 Draw a suitable conclusion for this investigation. (2)
- 6.5.4 What physical quantity does the gradient of the graph represent? (1)

[19]

**QUESTION 7 (Start on a new page.)**

In the circuit diagram below the potential difference across the terminals of a battery is 12 V when the current flowing is 1,2 A. The battery has an internal resistance of 1,5  $\Omega$ . The resistance of the ammeter and connecting wires can be ignored.

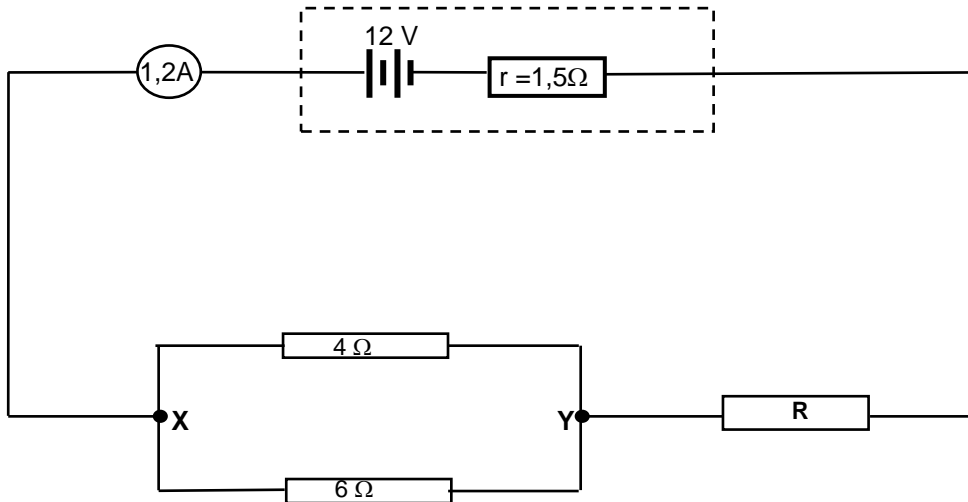

- 7.1 Calculate the resistance of the external resistors in the circuit. (3)
- 7.2 Calculate the resistance of resistor R. (4)
- 7.3 Determine the emf of the battery. (3)
- 7.4 A resistor of resistance  $2 \Omega$  is connected between the points X and Y.  
How will this affect the ammeter reading? Answer by writing only **INCREASE**, **DECREASE** or **REMAIN THE SAME**. (1)
- 7.5 Explain your answer to Question 7.4. (2)

[13]

**QUESTION 8 (Start on a new page.)**

The diagram below shows a type of generator. The coil rotates clockwise.

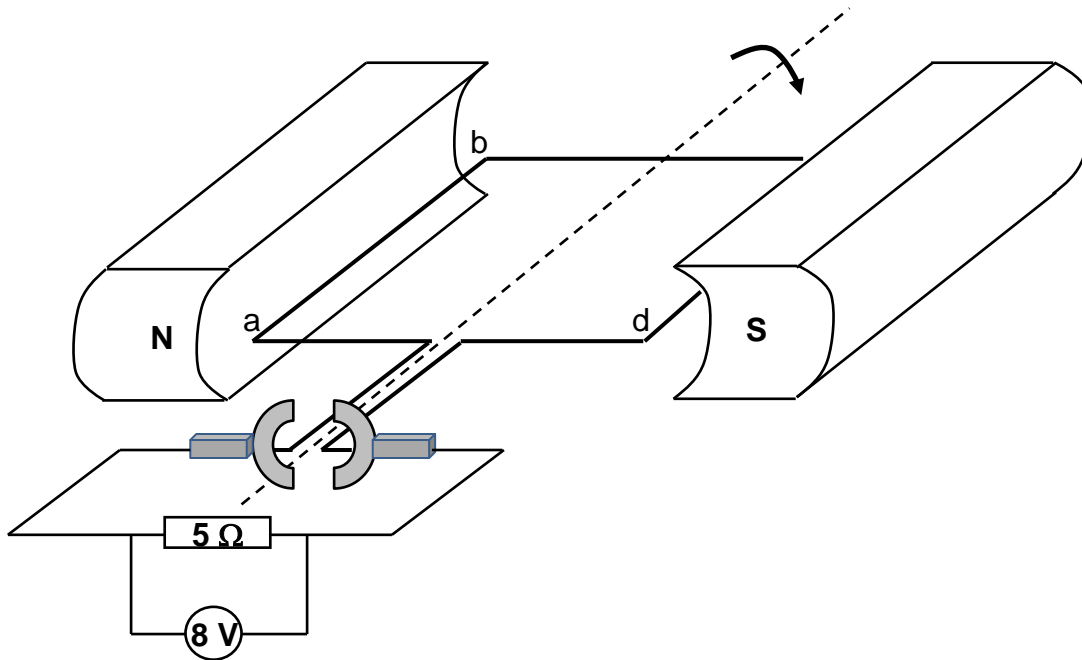

- 8.1 Name this type of generator (AC or DC). (1)
- 8.2 Give a reason for your answer to Question 8.1. (1)
- 8.3 For the position of the coil as shown, in which direction will the current flow? (Simply state **a to b** or **b to a**.) (1)
- 8.4 Define the term *rms current*. (2)
- 8.5 If the voltmeter shows a maximum voltage output of 8 V across the 5 Ω resistor, calculate the **rms** current output of the generator. (4)
- 8.6 Starting with the coil in the horizontal position as shown:
- 8.6.1 Draw a sketch graph of the output voltage for **one cycle** of the coil. (3)
- 8.6.2 Would the generator output current graph differ from the output voltage graph? (Simply state **YES** or **NO**.) (1)
- 8.6.3 Explain your answer to Question 8.6.2. (2)

[15]

**QUESTION 9 (Start on a new page.)**

The circuit shown below was used to investigate the photoelectric effect. Orange light with a wavelength of 600 nm incident on the metal surface ejected electrons from the metal surface. The ejected electrons had zero kinetic energy.

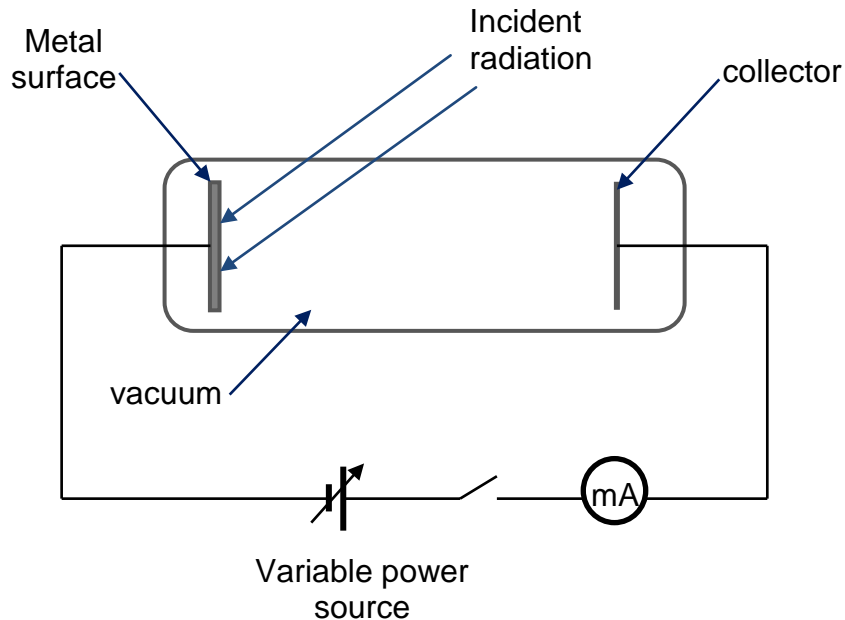

- 9.1 Briefly describe what the **photoelectric effect** is. (2)
  - 9.2 Define work function ( $W_0$ ) of a metal. (2)
  - 9.3 Calculate the work function of the metal. (4)
  - 9.4 The orange light is then replaced by a faint blue light. Will the milliammeter detect a photocurrent? (Answer **YES** or **NO**.) (1)
  - 9.5 Explain your answer to Question 9.4. (2)
- [11]**

**TOTAL: 150**

**END**

**DATA FOR PHYSICAL SCIENCES GRADE 12**  
**PAPER 1 (PHYSICS)**

**TABLE 1: PHYSICAL CONSTANTS**

<b>NAME</b>	<b>SYMBOL</b>	<b>VALUE</b>
Acceleration due to gravity	g	9,8 m·s <sup>-2</sup>
Universal gravitational constant	G	6,67 x 10 <sup>-11</sup> N·m <sup>2</sup> ·kg <sup>-2</sup>
Speed of light in a vacuum	c	3,0 x 10 <sup>8</sup> m·s <sup>-1</sup>
Planck's constant	h	6,63 x 10 <sup>-34</sup> J·s
Coulomb's constant	k	9,0 x 10 <sup>9</sup> N·m <sup>2</sup> ·C <sup>-2</sup>
Charge on electron	e	1,6 x 10 <sup>-19</sup> C
Electron mass	m <sub>e</sub>	9,11 x 10 <sup>-31</sup> kg
Mass of the earth	M	5,98 x 10 <sup>24</sup> kg
Radius of the earth	R <sub>E</sub>	6,38 x 10 <sup>6</sup> m



TABLE 2: FORMULAE

**MOTION**

$v_f = v_i + a \Delta t$	$\Delta x = v_i \Delta t + \frac{1}{2} a \Delta t^2$ or $\Delta y = v_i \Delta t + \frac{1}{2} a \Delta t^2$
$v_f^2 = v_i^2 + 2a\Delta x$ or $v_f^2 = v_i^2 + 2a\Delta y$	$\Delta x = \left( \frac{v_i + v_f}{2} \right) \Delta t$ or $\Delta y = \left( \frac{v_i + v_f}{2} \right) \Delta t$

**FORCE**

$F_{\text{net}} = ma$	$p = mv$
$f_s^{\text{max}} = \mu_s N$	$f_k = \mu_k N$
$F_{\text{net}} \Delta t = \Delta p$ $\Delta p = mv_f - mv_i$	$w = mg$
$F = G \frac{m_1 m_2}{d^2}$ or $F = G \frac{m_1 m_2}{r^2}$	$g = G \frac{M}{d^2}$ or $g = G \frac{M}{r^2}$

**WORK, ENERGY AND POWER**

$W = F \Delta x \cos \theta$	$U = mgh$ or $E_p = mgh$
$K = \frac{1}{2} mv^2$ or $E_k = \frac{1}{2} mv^2$	$W_{\text{net}} = \Delta K$ or $W_{\text{net}} = \Delta E_k$ $\Delta K = K_f - K_i$ or $\Delta E_k = E_{kf} - E_{ki}$
$W_{\text{nc}} = \Delta K + \Delta U$ or $W_{\text{nc}} = \Delta E_k + \Delta E_p$	$P = \frac{W}{\Delta t}$
$P_{\text{ave}} = Fv_{\text{ave}}$ / $P_{\text{gem}} = Fv_{\text{gem}}$	

**WAVES, SOUND AND LIGHT**

$v = f \lambda$	$T = \frac{1}{f}$
$f_L = \frac{v \pm v_L}{v \pm v_s} f_s$ $f_L = \frac{v \pm v_L}{v \pm v_b} f_b$	$E = hf$ or $E = h \frac{c}{\lambda}$
$E = W_o + E_{k(max)}$ or $E = W_o + K_{max}$ where $E = hf$ and $W_o = hf_o$ and $E_{k(max)} = \frac{1}{2} m v_{max}^2$ or $K_{max} = \frac{1}{2} m v_{max}^2$	

**ELECTROSTATICS**

$F = \frac{kQ_1 Q_2}{r^2}$	$E = \frac{kQ}{r^2}$
$V = \frac{W}{q}$	$E = \frac{F}{q}$
$n = \frac{Q}{e}$ or $n = \frac{Q}{q_e}$	

**ELECTRIC CIRCUITS**

$R = \frac{V}{I}$	$\text{emf } (\varepsilon) = I(R + r)$ $\text{emk } (\varepsilon) = I(R + r)$
$R_s = R_1 + R_2 + \dots$ $\frac{1}{R_p} = \frac{1}{R_1} + \frac{1}{R_2} + \dots$	$q = I\Delta t$
$W = Vq$ $W = VI\Delta t$ $W = I^2R\Delta t$ $W = \frac{V^2\Delta t}{R}$	$P = \frac{W}{\Delta t}$ $P = VI$ $P = I^2R$ $P = \frac{V^2}{R}$

**ALTERNATING CURRENT**

$I_{\text{rms}} = \frac{I_{\text{max}}}{\sqrt{2}}$ / $I_{\text{wgk}} = \frac{I_{\text{maks}}}{\sqrt{2}}$	$P_{\text{ave}} = V_{\text{rms}} I_{\text{rms}}$ / $P_{\text{gem}} = V_{\text{wgk}} I_{\text{wgk}}$
$V_{\text{rms}} = \frac{V_{\text{max}}}{\sqrt{2}}$ / $V_{\text{wgk}} = \frac{V_{\text{maks}}}{\sqrt{2}}$	$P_{\text{ave}} = I_{\text{rms}}^2 R$ / $P_{\text{gem}} = I_{\text{wgk}}^2 R$
	$P_{\text{ave}} = \frac{V_{\text{rms}}^2}{R}$ / $P_{\text{gem}} = \frac{V_{\text{wgk}}^2}{R}$