



NATIONAL SENIOR CERTIFICATE: PREPARATORY EXAMINATION
SEPTEMBER 2018

TO: THE CHIEF INVIGILATOR OF ALL SCHOOLS OFFERING
PHYSICAL SCIENCES P1: GRADE 12

ERRATA

Please take note of the following change:

Page	ERROR	CORRECTION
3 (1.1)	Two forces, F and $2F$, ... the diagram below.	Two forces of magnitudes F and $2F$, act in opposite ... the diagram below
5 (1.8)	A man has a mass m , and a weight w , what ... as the Earth?	A man has a mass m , and a weight w on Earth, what ... as the Earth?
5 (1.9 2 nd line)	Assume that the object rebounds.	Assume that the object rebounds in the opposite direction.
8 (statement)	... she throws a 1kg block forward as shown ... below.	... she throws a 1kg object forward at 10 m.s^{-1} as shown ... below.

Kindly ensure that candidates are informed of the Errata.

MS H.J.E. COETZEE
ASSISTANT DIRECTOR
PROVINCIAL EXAMINATION

11/9/2018
DATE



education

Department:
Education
PROVINCE OF KWAZULU-NATAL

**NATIONAL
SENIOR CERTIFICATE**

GRADE 12

PHYSICAL SCIENCES: PHYSICS (P1)

PREPARATORY EXAMINATION

SEPTEMBER 2018

MARKS: 150

TIME : 3 hours

This question paper consists of 14 pages and 3 data sheets.

INSTRUCTIONS AND INFORMATION TO CANDIDATES

1. Write your name on the **ANSWER BOOK**.
2. This question paper consists of TEN questions. Answer ALL the questions in the ANSWER BOOK.
3. Start EACH question on a NEW page in the ANSWER BOOK.
4. Number the answers correctly according to the numbering system used in this question paper.
5. Leave ONE line between two subsections, for example between QUESTION 2.1 and QUESTION 2.2.
6. You may use a non-programmable calculator.
7. You may use appropriate mathematical instruments.
8. You are advised to use the attached DATA SHEET.
9. Show ALL formulae and substitutions in ALL calculations.
10. Round off your final numerical answers to a minimum of TWO decimal places.
11. Give brief motivations, discussions, et cetera where required.
12. Write neatly and legibly.

QUESTION 1: MULTIPLE- CHOICE QUESTIONS

Four options are provided as possible answers to the following questions. Each question has only ONE correct answer. Write only the letter (A - D) next to the question number (1.1 – 1.10) in the ANSWER BOOK, for example 1.4 D.

- 1.1 Two forces, **F** and **2F**, in opposite directions on a box placed on a frictionless surface block as shown in the diagram below.

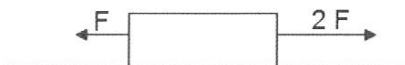

Which one of the following statements correctly describes the motion of the block?

- A The block moves at constant velocity to the right.
B The block moves with increasing acceleration to the right.
C The block moves with constant acceleration to the right.
D The block moves with constant acceleration to the left. (2)
- 1.2 A ball is dropped vertically downwards from rest. Ignore air friction. The ball attains a velocity **v** after it has travelled a vertical distance **2y**. When the ball has travelled a vertical distance of **8y**, the magnitude of its velocity, in terms of **v**, will be... (2)
- A $\frac{1}{2}v$
B $\sqrt{2}v$
C $2v$
D $4v$
- 1.3 A line emission spectrum is produced when an electron in an excited atom makes a transition from ... (2)
- A higher to lower energy levels and emits light energy.
B higher to lower energy levels and absorbs light energy.
C lower to higher energy levels and emits light energy.
D lower to higher energy levels and absorbs light energy.

- 1.4 A police car, with its siren on, is moving away at constant speed from a stationary observer. The siren emits a sound of constant frequency. Which of the following characteristics, associated with the sound emitted by the siren is/are CORRECT, as perceived by the observer?

- (i) The speed remains the same.
- (ii) The frequency increases.
- (iii) The wavelength increases.
- (iv) The frequency decreases.

- A (iii) only
- B (i), (iii) and (iv)
- C (i) and (iii) only
- D (i) and (ii) only (2)

- 1.5 In the circuits below, the batteries provide the same potential difference and all the light bulbs are identical. The resistance of the connecting wires and the batteries are negligible. The power in bulb X is P.

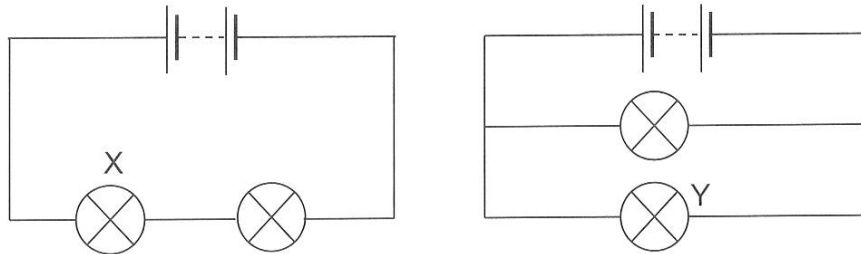

The power in bulb Y is...

- A $\frac{1}{2}P$
 - B $\frac{1}{4}P$
 - C $2P$
 - D $4P$ (2)
- 1.6 A block slides across a rough, horizontal surface. The work done by friction changes only the:
- A Internal energy
 - B Potential energy
 - C Kinetic and internal energies
 - D Potential and kinetic energies (2)

- 1.7 The energy of a certain photon is twice the work function of a certain metal. The photon is incident on the metal surface. Which one of the following statements below, about the photon, is correct?
- A It ejects a single photo-electron with kinetic energy equivalent to the work function.
 - B It has sufficient energy such that it releases two photo-electrons.
 - C It ejects two photo-electrons each of energy equivalent to the work function.
 - D It has sufficient energy such that it adds two photo-electrons. (2)

- 1.8 A man has a mass m , and a weight w . What is the man's mass and weight on a planet which has twice the mass of the Earth and has the same radius as the Earth?

	Mass	Weight
A	m	w
B	$2m$	w
C	$2m$	$2w$
D	m	$2w$

(2)

- 1.9 An object of mass m travelling at speed v along a straight line, collides head-on with a wall. Assume that the collision is elastic and the object rebounds. What are the changes in the momentum and in the kinetic energy of the object, as a result of the collision?

	Change in momentum	Change in kinetic energy
A	0	0
B	0	mv^2
C	$2mv$	0
D	mv^2	0

(2)

- 1.10 The centres of two identical metallic spheres, each carrying a charge Q , are a distance r apart. Which ONE of the following pairs of changes (that are made simultaneously) will double the electrostatic force that one charged sphere exerts on the other?

	Distance between centres of spheres	Magnitude of charges
A	Decrease distance to $\frac{r}{\sqrt{2}}$	Double the charge on each sphere
B	Decrease distance to $\frac{r}{\sqrt{2}}$	Reduce charge on each sphere to $\frac{Q}{2}$
C	Decrease distance to $\frac{r}{2}$	Reduce the charge on one sphere to $\frac{Q}{2}$
D	Decrease distance to $\frac{r}{2}$	Double the charge on each sphere

(2)
[20]

QUESTION 2 (Start on a new page)

A 9 kg box, which is held at rest on a rough horizontal surface, is connected by a light inextensible string passing over a light frictionless pulley to an object of mass 2,5 kg hanging vertically.

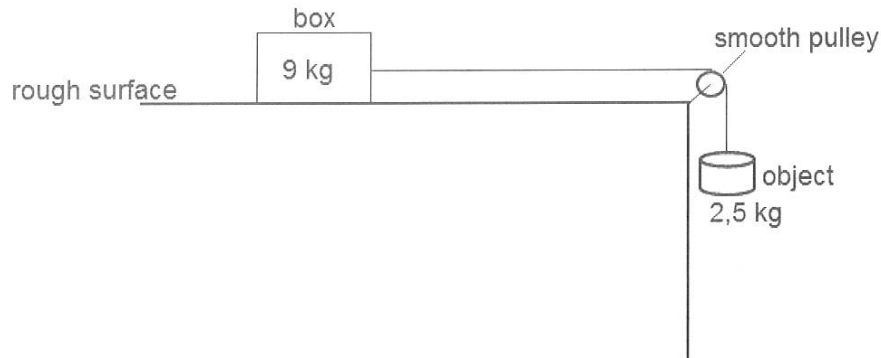

When the box is released, a frictional force of 6 N acts on it.

- 2.1 State *Newton's Second Law of Motion* in words. (2)
- 2.2 Draw a labelled free-body diagram of the 9 kg box. (4)
- 2.3 Calculate the magnitude of the acceleration of the object. (5)

Once every month, a “new moon” is observed when Earth and moon orbit the sun. When this happens the three bodies line up as shown in the picture below.

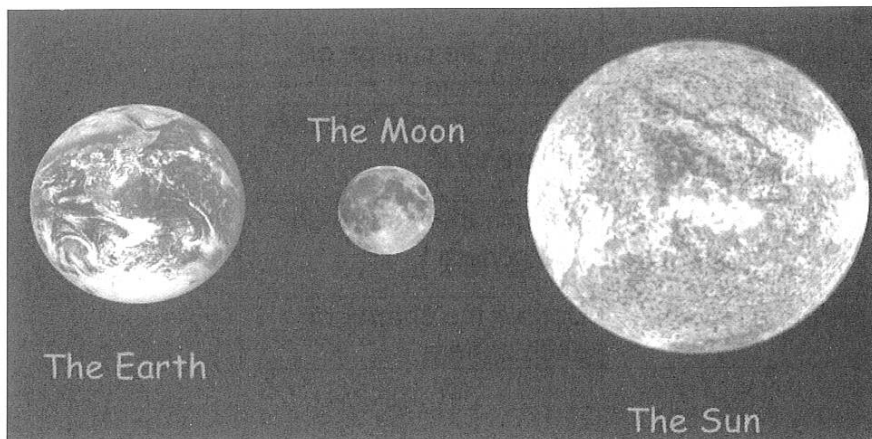

During this period the Moon experiences a **net zero gravitational force**.

Take the : mass of the Sun as $1,99 \times 10^{30}$ kg;
 mass of the Moon as $7,35 \times 10^{22}$ kg;
 gravitational force of attraction between the Moon and the Earth as $1,997 \times 10^{20}$ N.

- 2.4 Calculate the distance between the centres of the Sun and the Moon during the “new moon”. (5)

[16]

QUESTION 3 (Start on a new page)

Ball **Y** is thrown vertically upwards from the ground at a velocity of $20 \text{ m}\cdot\text{s}^{-1}$.

AT THE SAME INSTANT, a second ball **X** is dropped from a balcony 50 m above the ground. Refer to the diagram below. Ignore the effects of air resistance.

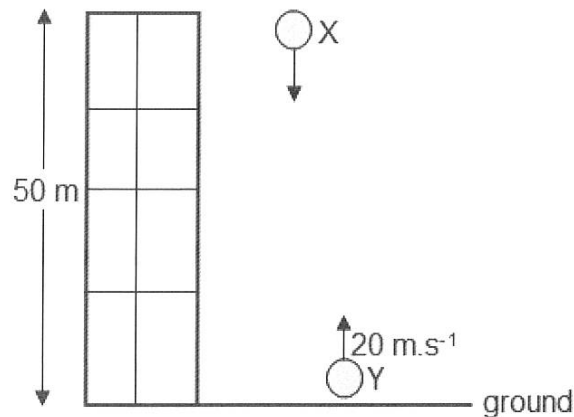

- 3.1 Define the term *projectile*. (2)
- 3.2 Calculate the time it will take the balls to pass each other. (5)
- 3.3 Calculate how high above the ground ball **X** will be at the instant the two balls just pass each other. (4)
- 3.4 Draw the position-time graph for ball **X** from the moment it is dropped until it passes ball **Y**.

Indicate the following on the graph:

- Initial position of ball **X**.
- Position of ball **X**, above the ground, when it passed ball **Y**.
- Time it takes the balls to pass each other.

(4)
[15]

QUESTION 4 (Start on a new page)

A girl sits in a boat, which is initially stationary, in the middle of a lake. In trying to propel herself back to the shore, she throws a 1 kg block forward as shown in the diagram below. Assume the combined mass of the girl and the boat is 100 kg.

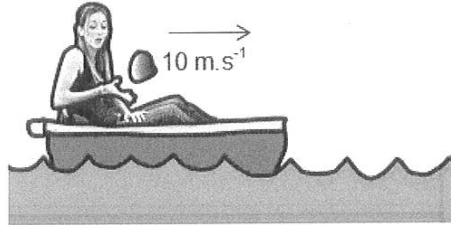

Ignore friction between the water and the boat. Also ignore the up and down motion of the boat.

- 4.1 Define *momentum* in words. (2)
- 4.2 Write down the initial momentum of the boat and the object. (1)
- 4.3 Calculate the momentum of the object immediately after it has been thrown. (3)
- 4.4 Calculate the velocity of the girl after the object has been thrown. (5)
- [11]**

QUESTION 5 (Start on a new page)

A crate of mass 50 kg slides down a rough inclined plane that makes an angle of 30° with the horizontal, as shown in the diagram below. The crate experiences a constant frictional force of magnitude 190 N during its motion down the incline. The crate passes point **X** at a speed of $2 \text{ m}\cdot\text{s}^{-1}$ and moves a distance of 10 m before reaching point **Y** lower down the incline. Neglect any effects of air resistance.

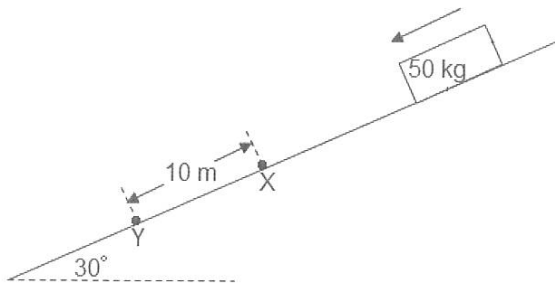

- 5.1 State the *work-energy theorem* in words. (2)
- 5.2 Draw a labelled free-body diagram showing all the forces acting on the crate as it moves down the incline. (3)
- 5.3 Calculate the net work done on the crate during its motion from point **X** to point **Y**. (4)
- 5.4 Use energy principles to calculate the speed of the crate at point **Y**. (4)
- [13]**

QUESTION 6 (Start on a new page)

A man mounts a siren on the roof of his car. The siren produces a constant frequency of 600 Hz. He drives the car at a constant speed up and down a straight road while a stationary listener takes some readings. After a while, the listener obtains the following pressure-time graph from the readings taken.

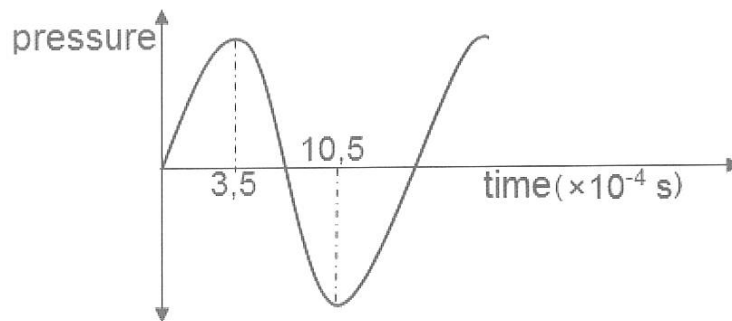

- 6.1 Determine the period of the detected wave. (2)
- 6.2 Calculate the frequency of the detected sound wave. (3)
- 6.3 State the *Doppler Effect* in words. (2)
- 6.4 Calculate the speed of the moving car. (5)
- (Take the speed of sound in air as $340 \text{ m}\cdot\text{s}^{-1}$)

[12]

QUESTION 7 (Start on a new page)

Sphere **A**, which has a charge of $+5 \text{ nC}$, is brought into contact with sphere **B**, which has a charge of -8 nC . The spheres are separated after contact as shown in the diagram below.

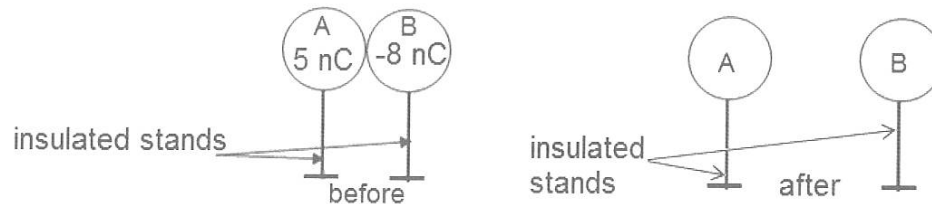

- 7.1 Calculate the charge (in Coulombs) on sphere **A** after separation. (3)
- 7.2 Sphere **R**, which has a charge of $4.8 \times 10^{-8} \text{ C}$, is suspended by a light inextensible thread. Sphere **S**, which has a charge of $-1.2 \times 10^{-8} \text{ C}$, is positioned on an insulated stand near sphere **R** and in line with it. Sphere **R** is attracted to sphere **S** and comes to rest at distance x from sphere **S** as shown in the diagram below. When sphere **R** is in this equilibrium position, the angle between the thread and the horizontal is 60° and the tension (T) in the thread is $0,07 \text{ N}$.

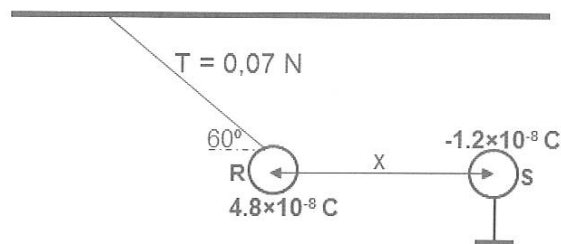

- 7.2.1 State *Coulomb's Law* in words. (2)
- 7.2.2 Sketch the net electric field pattern due to the two spheres, **R** and **S**. (3)
- 7.2.3 Calculate the magnitude of the horizontal component of the tension in the thread. (2)
- 7.2.4 Calculate the distance x between the centres of spheres **R** and **S**. (4)
- [14]

QUESTION 8 (Start on a new page)

An electric circuit is set up as shown in the diagram below. The resistances of the switch, ammeters and connecting wires are negligible. The voltmeters have very high resistance. The battery has an emf (\mathcal{E}) of 19 V and has significant internal resistance (r).

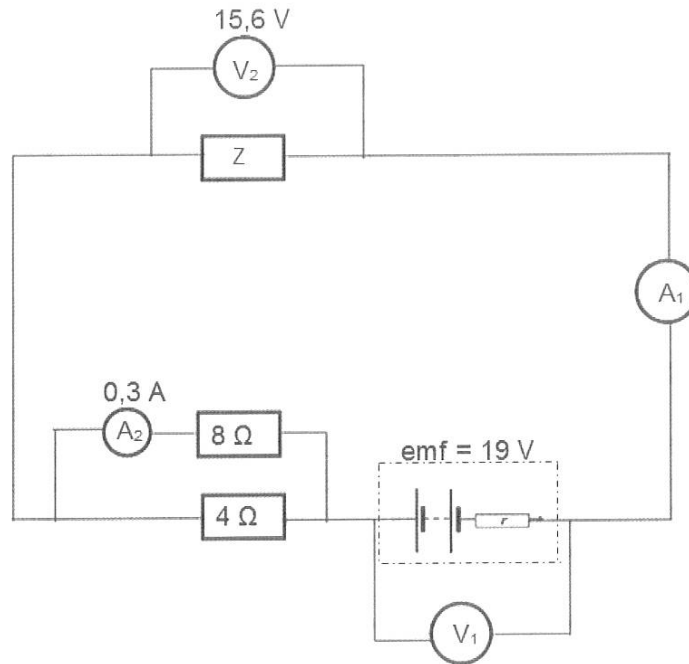

8.1 State *Ohm's Law* in words. (2)

8.2 The ammeter A_2 reads 0,3 A and the voltmeter V_2 reads 15,6 V.

Calculate:

8.2.1 The reading on ammeter A_1 . (4)

8.2.2 The resistance of resistor Z . (3)

8.2.3 The total external resistance of the circuit. (3)

8.2.4 The internal resistance (r) of the battery. (4)

8.3 Resistor Z is replaced by a new resistor whose resistance is smaller than that of Z .

8.3.1 Will the reading on the voltmeter V_1 , connected across the terminals of the battery, INCREASE, DECREASE, or REMAIN THE SAME? (1)

8.3.2 Explain your answer to QUESTION 8.3.1, making reference to relevant formulae. (4)

[21]

QUESTION 9 (Start on a new page)

A simplified diagram of a generator is shown below.

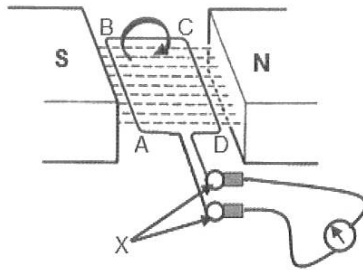

9.1 Name the parts of the generator labelled X. (1)

9.2 The coil starts in the horizontal position. It takes 0.01×10^{-3} s to rotate the coil through 90° . The maximum output voltage is 50 V.

Sketch a graph of output voltage versus *time* for 0.08×10^{-3} s of this generator's operation, beginning with the position given in the diagram at time, $t = 0$ s. (4)

9.3 State ONE way in which the generator shown above can be used to produce a higher output voltage. (2)

9.4 A certain AC generator produces a peak current (I_{\max}) of 6,27 A when connected to an electrical appliance of resistance 52,6 Ω .

9.4.1 Calculate the rms current (I_{rms}) produced by the generator. (3)

9.4.2 Calculate the peak voltage (V_{\max}) of the generator. (5)

[15]

QUESTION 10 (Start on a new page)

The diagram below shows a circuit in which a photocell is connected to an ammeter.

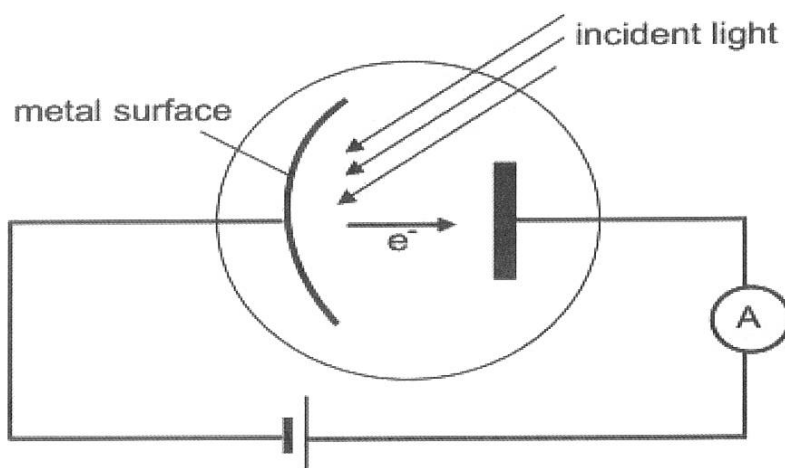

- 10.1 When the metal plate is irradiated with red light, the ammeter shows a reading. Explain this observation. (2)
- 10.2 The plate is now irradiated with blue light having the same intensity as the red light. State how this change will influence each of the following:
- 10.2.1 The kinetic energy of the photo-electrons (Choose from INCREASE, DECREASE or STAYS THE SAME.) (1)
- 10.2.2 The ammeter reading. (Choose from INCREASE, DECREASE or STAYS THE SAME.). Give an explanation for your answer. (4)
- 10.3 The wavelength of the blue light used in the demonstration is $4,5 \times 10^{-7} \text{ m}$. Calculate the threshold frequency of the metal used in the photocell if the average speed of an emitted photo-electron is equal to $5,06 \times 10^5 \text{ m}\cdot\text{s}^{-1}$. (6)
- [13]**

GRAND TOTAL: 150

**DATA FOR PHYSICAL SCIENCES GRADE 12
PAPER 1 (PHYSICS)**

**GEGEWENS VIR FISIESTE WETENSKAPPE GRAAD 12
VRAESTEL 1 (FISIKA)**

TABLE 1: PHYSICAL CONSTANTS / TABEL 1: FISIESTE KONSTANTES

NAME / NAAM	SYMBOL / SIMBOOL	VALUE / WAARDE
Acceleration due to gravity <i>Swaartekragversnelling</i>	g	9,8 m·s ⁻²
Universal gravitational constant <i>Universele gravitasiekonstante</i>	G	6,67 × 10 ⁻¹¹ N·m ² ·kg ⁻²
Speed of light in a vacuum <i>Spoed van lig in 'n vakuum</i>	c	3,0 × 10 ⁸ m·s ⁻¹
Planck's constant <i>Planck se konstante</i>	h	6,63 × 10 ⁻³⁴ J·s
Coulomb's constant <i>Coulomb se konstante</i>	k	9,0 × 10 ⁹ N·m ² ·C ⁻²
Charge on electron <i>Lading op electron</i>	e ⁻	-1,6 × 10 ⁻¹⁹ C
Electron mass <i>Elektronmassa</i>	m _e	9,11 × 10 ⁻³¹ kg
Mass of Earth <i>Massa van Aarde</i>	M	5,98 × 10 ²⁴ kg
Radius of Earth <i>Radius van Aarde</i>	R _E	6,38 × 10 ⁶ m

TABLE 2: FORMULAE / TABEL 2: FORMULES**MOTION / BEWEGING**

$v_f = v_i + a \Delta t$	$\Delta x = v_i \Delta t + \frac{1}{2} a \Delta t^2$ or/of $\Delta y = v_i \Delta t + \frac{1}{2} a \Delta t^2$
$v_f^2 = v_i^2 + 2a\Delta x$ or/of $v_f^2 = v_i^2 + 2a\Delta y$	$\Delta x = \left(\frac{v_i + v_f}{2} \right) \Delta t$ or/of $\Delta y = \left(\frac{v_i + v_f}{2} \right) \Delta t$

FORCE / KRAG

$F_{\text{net}} = ma$	$p = mv$
$f_{s(\text{max})} = \mu_s N$	$f_k = \mu_k N$
$F_{\text{net}} \Delta t = \Delta p$ $\Delta p = mv_f - mv_i$	$w = mg$
$F = \frac{Gm_1 m_2}{r^2}$	$g = \frac{Gm}{r^2}$

WORK, ENERGY AND POWER / ARBEID, ENERGIE EN DRYWING

$W = F \Delta x \cos \theta$	$U = mgh$ or/of $E_p = mgh$
$K = \frac{1}{2} mv^2$ or/of $E_k = \frac{1}{2} mv^2$	$W_{\text{net}} = \Delta K$ or/of $W_{\text{net}} = \Delta E_k$ $\Delta K = K_f - K_i$ or/of $\Delta E_k = E_{kf} - E_{ki}$
$W_{\text{nc}} = \Delta K + \Delta U$ or/of $W_{\text{nc}} = \Delta E_k + \Delta E_p$	$P = \frac{W}{\Delta t}$
$P_{\text{av}} = F \cdot v_{\text{av}}$ / $P_{\text{gem}} = F \cdot v_{\text{gem}}$	

WAVES, SOUND AND LIGHT / GOLWE, KLANK EN LIG

$v = f \lambda$	$T = \frac{1}{f}$
$f_L = \frac{v \pm v_L}{v \pm v_s} f_s$	$E = hf$ or/of $E = h \frac{c}{\lambda}$
$E = W_o + E_{k(\text{max})}$ or/of $E = W_o + K_{(\text{max})}$ where/waar	
$E = hf$ and/en $W_o = hf_o$ and/en $E_{k(\text{max})} = \frac{1}{2} mv_{\text{max}}^2$ or/of $K_{(\text{max})} = \frac{1}{2} mv_{\text{max}}^2$	

ELECTROSTATICS / ELEKTROSTATIKA

$F = \frac{kQ_1Q_2}{r^2}$	$E = \frac{kQ}{r^2}$
$V = \frac{W}{q}$	$E = \frac{F}{q}$
$n = \frac{Q}{e}$ OR/OF $n = \frac{Q}{q_e}$	

ELECTRIC CIRCUITS / ELEKTRIESE STROOMBANE

$R = \frac{V}{I}$	emf (ϵ) = I (R + r) emk (ϵ) = I(R + r)
$R_s = R_1 + R_2 + \dots$ $\frac{1}{R_p} = \frac{1}{R_1} + \frac{1}{R_2} + \dots$	$q = I \Delta t$
$W = Vq$ $W = VI \Delta t$ $W = I^2 R \Delta t$ $W = \frac{V^2 \Delta t}{R}$	$P = \frac{W}{\Delta t}$ $P = VI$ $P = I^2 R$ $P = \frac{V^2}{R}$

ALTERNATING CURRENT / WISSELSTROOM

$I_{rms} = \frac{I_{max}}{\sqrt{2}}$ / $I_{wgk} = \frac{I_{maks}}{\sqrt{2}}$	$P_{ave} = V_{rms} I_{rms}$ / $P_{gemiddeld} = V_{wgk} I_{wgk}$
$V_{rms} = \frac{V_{max}}{\sqrt{2}}$ / $V_{wgk} = \frac{V_{maks}}{\sqrt{2}}$	$P_{ave} = I_{rms}^2 R$ / $P_{gemiddeld} = I_{wgk}^2 R$
	$P_{ave} = \frac{V_{rms}^2}{R}$ / $P_{gemiddeld} = \frac{V_{wgk}^2}{R}$

QUESTION 1

- 1.1 C✓✓
- 1.2 C✓✓
- 1.3 A✓✓
- 1.4 B✓✓
- 1.5 D✓✓
- 1.6 C✓✓
- 1.7 A✓✓
- 1.8 D✓✓
- 1.9 C✓✓
- 1.10 C✓✓

QUESTION 2

2.1 When a resultant/net force acts on an object, the object will accelerate in the direction of the force at an acceleration directly proportional to the force✓ and inversely proportional to the mass of the object. ✓

OR

The resultant/net force acting on an object is equal to the rate of change of momentum of the object in the direction of the resultant/net force. ✓✓

2.2

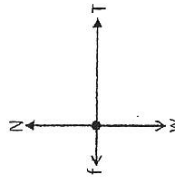

Notes : Accepted labels		Mark
w	Weight / F_g / F_G	✓
T	Tension in string	✓
f	Frictional force	✓
N	Normal force	✓

2.3

Box
 $F_{net} = ma✓$
 $T + (-f) = ma$
 $T - 6 = 9a.....(1) ✓$

Substituting (1) into (2):
 $-6 + (2.5)(9.8) = 11.5a✓$
 $a = 1.61 \text{ m.s}^{-2}✓$

Object
 $F_{net} = ma$
 $w + (-T) = ma$
 $(2.5)(9.8) - T = 2.5a.....(2) ✓$

2.4 $F = G \frac{M_1 M_2}{r^2} ✓$

But $F_{E\&M} = F_{S\&M} ✓$ (net zero gravitational force)

$1,997 \times 10^{20} ✓ = \frac{(6.67 \times 10^{-11})(7.35 \times 10^{22})(1.99 \times 10^{30})}{r^2} ✓$

$r = 2.21 \times 10^{11} \text{ m} ✓$

(5)
[16]

QUESTION 3

3.1 An object upon which the only force acting is the force of gravity. ✓✓ (2)

OPTION 1

Upward is positive

Ball Y

$\Delta y_1 = v_1 \Delta t + \frac{1}{2} a \Delta t^2 ✓$
 $= 20t + \frac{1}{2}(-9.8) \Delta t^2$
 $= 20t - 4.9 t^2.....(1) ✓$

Now, $20t - 4.9 t^2 = -4.9t^2 + 50 ✓$
 $20t = 50$
 $t = 2.5 \text{ s} ✓$

Ball X

$\Delta y_2 = v_1 \Delta t + \frac{1}{2} a \Delta t^2$
 $-(50 - \Delta y_1) = (0)(\Delta t) + \frac{1}{2}(-9.8) \Delta t^2$
 $\Delta y_1 = -4.9t^2 + 50.....(2) ✓$

(5)

Upward is negative

Ball Y

$\Delta y_1 = v_1 \Delta t + \frac{1}{2} a \Delta t^2 ✓$
 $-\Delta y_1 = -20t + \frac{1}{2}(9.8) \Delta t^2$
 $\Delta y_1 = 20t - 4.9 t^2.....(1) ✓$

Solving (1) and (2):
 $20t = 50 ✓$
 $t = 2.5 \text{ s} ✓$

Ball X

$\Delta y_2 = v_1 \Delta t + \frac{1}{2} a \Delta t^2$
 $(50 - \Delta y_1) = (0)(\Delta t) + \frac{1}{2}(-9.8) \Delta t^2$
 $\Delta y_1 = -4.9t^2 + 50.....(2) ✓$

OPTION 2

The balls are approaching each other (relative velocity increases)

$(v_x + v_y) = \frac{\Delta x}{\Delta t} ✓$
 $(0 ✓ + 20 ✓) = \frac{50}{\Delta t} ✓$
 $\Delta t = 2.5 \text{ s} ✓$

(5)

3.3

OPTION 1	OPTION 2
$\Delta y = v_i \Delta t + \frac{1}{2} a \Delta t^2$ ✓ $= (20)(2.5) + \frac{1}{2}(-9.8)(2.5)^2$ ✓ $= 19.375 \text{ m}$ ✓ $h = 19.375 \text{ m}$ ✓	$\Delta y = v_i \Delta t + \frac{1}{2} a \Delta t^2$ ✓ $= (0)(2.5) + \frac{1}{2}(-9.8)(2.5)^2$ ✓ $= -30.625$ ✓ $h = 50 - (-30.625)$ ✓ $= 19.375 \text{ m}$ ✓

OPTION 3

Ball X

$v_f = v_i + a\Delta t$
 $= 0 + (-9.8)(2.5)$ ✓
 $v_f = -24.50 \text{ m}\cdot\text{s}^{-1}$ ✓

E_m at top = E_m at meeting point
 $(mgh + \frac{1}{2}mv^2)_{\text{at top}} = mgh + \frac{1}{2}mv^2_{\text{at meeting point}}$ ✓
 $m(9.8)(50) + 0 = m(9.8)\Delta y + \frac{1}{2}m(-24.50)^2$ ✓
 $\Delta y = 19.375 \text{ m}$ ✓
 $h = 19.375 \text{ m}$ ✓

3.4 Mark positively from 3.2 and 3.3
 OPTION 1 (downward is positive)

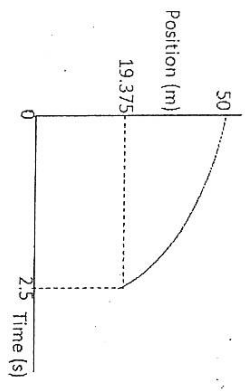

- Criteria**
- Shape ✓
 - Starts at 50 m ✓
 - Ends at 2.5 s ✓
 - Ends at 19.375m ✓

OPTION 2 (downward is negative)

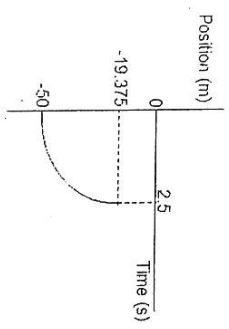

- Criteria**
- Shape ✓
 - Starts at -50 m ✓
 - Ends at 2.5 s ✓
 - Ends at -19.375m ✓

OPTION 3

Can shift the lower graph to start at the origin, and the rest will remain the same. (4)

QUESTION 4

- 4.1 The product of mass and velocity of the object. ✓✓ (2)
- 4.2 $0 \text{ kg}\cdot\text{m}\cdot\text{s}^{-1}$ (Accept 0 / Zero) ✓ (1)

4.3 To the right is positive

$p = mv$ ✓
 $= (1)(10)$ ✓
 $= 10 \text{ kg}\cdot\text{m}\cdot\text{s}^{-1}$ to the right ✓

To the right is positive

$p = mv$ ✓
 $= (1)(-10)$ ✓
 $= -10 \text{ kg}\cdot\text{m}\cdot\text{s}^{-1}$
 $= 10 \text{ kg}\cdot\text{m}\cdot\text{s}^{-1}$ (to the right) ✓ (3)

4.4 To the right is positive

$\Sigma p_{\text{before}} = \Sigma p_{\text{after}}$ ✓
 $0v = 100v_{\text{ab}} + 10v$ ✓
 $v_{\text{ab}} = -0.1 \text{ m}\cdot\text{s}^{-1}$ ✓
 $v_{\text{ab}} = 0.1 \text{ m}\cdot\text{s}^{-1}$ to the left ✓ (5)

To the right is negative

$\Sigma p_{\text{before}} = \Sigma p_{\text{after}}$ ✓
 $0v = 100v_{\text{ab}} + (-10)v$ ✓
 $v_{\text{ab}} = 0.1 \text{ m}\cdot\text{s}^{-1}$ to the left ✓ (5)

QUESTION 5

- 5.1 The work done by a net force on an object is equal to the change in the kinetic energy of the object. ✓
- OR
- Net work done on an object is equal to the change in the kinetic energy of the object. ✓ (2)

5.2

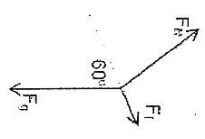

- F_g = gravitational force or weight ✓
 F_N / N = normal force ✓
 F_f / f = frictional force ✓

NB : Ignore the relative lengths the forces

5.3 OPTION 1

$$\begin{aligned}
 W_{\text{net}} &= F_{\text{net}} \Delta x \cos \theta \checkmark \\
 &= W_f + W_{F_{\text{gr}}} \checkmark \\
 &= (190)(10)(\cos 180^\circ) \checkmark + (50)(9.8)(\sin 30^\circ)(10)(\cos 0^\circ) \checkmark \\
 &= -1900 + 2450 \\
 &= 550 \text{ J} \checkmark
 \end{aligned}$$

(4)

OPTION 2

$$\begin{aligned}
 F_{\text{net}} &= F_{\text{gr}} - F_r \\
 &= \frac{(50)(9.8)(\sin 30^\circ)}{55} - 190 \checkmark \\
 &= 55 \text{ N}
 \end{aligned}$$

$$\begin{aligned}
 F_{\text{net}} &= ma \\
 55 &= 50a \\
 a &= 1.10 \text{ m.s}^{-2}
 \end{aligned}$$

$$\begin{aligned}
 v_f^2 &= v_i^2 + 2a\Delta x \\
 &= 2^2 + 2(1.10)(10) \checkmark \\
 v_f &= 5.10 \text{ m.s}^{-1}
 \end{aligned}$$

$$\begin{aligned}
 W_{\text{net}} &= \frac{1}{2}mv_f^2 - \frac{1}{2}mv_i^2 \checkmark \\
 &= \frac{1}{2}(50)(5.10)^2 - \frac{1}{2}(50)(2)^2 \\
 &= 550 \text{ J} \checkmark
 \end{aligned}$$

OPTION 3

$$\begin{aligned}
 W_{\text{net}} &= W_f + W_{F_{\text{gr}}} \checkmark \\
 &= (50)(9.8)(10)\cos 60^\circ \checkmark - 1900 \checkmark \\
 &= 550 \text{ J} \checkmark
 \end{aligned}$$

5.4 POSITIVE MARKING FROM QUESTION 5.3

OPTION 1

$$\begin{aligned}
 W_{\text{net}} &= \Delta K \checkmark \\
 &= \frac{1}{2}mv_f^2 - \frac{1}{2}mv_i^2 \\
 550 \checkmark &= \frac{1}{2}(50)(v_f^2 - 2^2) \checkmark \\
 v_f &= 5.10 \text{ m.s}^{-1} \checkmark
 \end{aligned}$$

OPTION 2

$$\begin{aligned}
 W_{\text{nc}} &= \Delta K + \Delta U \checkmark \\
 -1900 &= \frac{1}{2}(50)(v^2 - 2^2) + (50)(9.8)(h_f - h_i) \checkmark \\
 -1900 \checkmark &= \frac{1}{2}(50)(v^2 - 2^2) + (50)(9.8)(-10\sin 30^\circ) \checkmark \\
 v &= 5.10 \text{ m.s}^{-1} \checkmark
 \end{aligned}$$

(4) [13]

QUESTION 6

6.1 $14 \times 10^{-4} \text{ s} \checkmark \checkmark$

(2)

6.2 POSITIVE MARKING FROM QUESTION 6.1

$$\begin{aligned}
 f &= \frac{1}{T} \checkmark \\
 &= \frac{1}{14 \times 10^{-4}} \checkmark \\
 &= 714.29 \text{ Hz} \checkmark
 \end{aligned}$$

(3)

6.3 It is the change in frequency (or pitch) of the sound detected by a listener because the sound source and the listener have different velocities relative to the medium of sound propagation. $\checkmark \checkmark$

OR

It is the change in the observed frequency of a sound wave when the source of sound is moving relative to the listener. $\checkmark \checkmark$

(2)

6.4 POSITIVE MARKING FROM QUESTION 6.1

$$\begin{aligned}
 f_L &= \frac{v + v_L}{v - v_S} f_s \checkmark \\
 (714.29) \checkmark &= \left(\frac{340}{340 - v_S} \right) \checkmark (600) \checkmark \\
 v_S &= 54.40 \text{ m.s}^{-1} \checkmark \quad (\text{accept } 54.28 \text{ to } 54.40 \text{ m.s}^{-1})
 \end{aligned}$$

(5)

[12]

QUESTION 7

$$\begin{aligned}
 7.1 \quad Q_{\text{new}} &= \frac{Q_1 + Q_2}{2} \\
 &= \frac{(5 \times 10^{-9}) \checkmark + (-8 \times 10^{-9}) \checkmark}{2} \\
 &= -1.5 \times 10^{-9} \text{ C} \checkmark
 \end{aligned}$$

(3)

7.2.1 The magnitude of the electrostatic force exerted by one point charge (Q_1) on another point charge (Q_2) is directly proportional to the product of the magnitudes of the charges \checkmark and inversely proportional to the square of the distance (r) between them. \checkmark

OR

The force of attraction or repulsion between two point charges is directly proportional to the product of the charges \checkmark and inversely proportional to the square of the distance between them. \checkmark

(2)

7.2.2

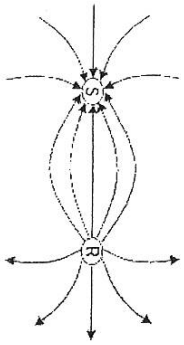

Criteria for marking the diagram	Marks
Correct shape	✓
Correct direction	✓
Field lines not touching each other or entering the spheres	✓

(3)

$$7.2.3 \quad T_x = (0,07)\cos 60^\circ \checkmark$$

$$= 0,035 \text{ N} \checkmark$$

(2)

$$7.2.4 \quad F = \frac{kQ_1 Q_2}{r^2} \checkmark$$

$$0,035 \checkmark = \frac{(9 \times 10^9)(4,8 \times 10^{-8})(1,2 \times 10^{-8})}{r^2} \checkmark$$

$$r = 0,012 \text{ m}$$

$$x = 0,012 \text{ m} \checkmark$$

OR

$$E = \frac{F_{ns}}{Q}$$

$$E = \frac{0,035}{4 \times 10^{-9}} \checkmark = 729166,67 \text{ N/C either} \checkmark$$

$$E = k \frac{Q}{r^2}$$

$$729166,67 = k \frac{1,2 \times 10^{-8}}{r^2} \checkmark$$

$$r = 0,012 \text{ m} \checkmark$$

(4)

[15]

QUESTION 8

- 8.1 The potential difference across the ends of the conductor is directly proportional to the current flowing to the conductor at constant temperature. ✓✓ (2)

8.2.1 OPTION 1

$$R_{8\Omega} = \frac{V}{I} \checkmark$$

$$8 = \frac{V}{0,3}$$

$$V = 2,4 \text{ V}$$

$$R_{4\Omega} = \frac{V}{I} \checkmark$$

$$4 = \frac{2,4}{I}$$

$$I = 0,6 \text{ A} \checkmark$$

$$I_{\text{tot}} = (0,3 + 0,6) \checkmark = 0,9 \text{ A} \checkmark$$

$$I = 0,9 \text{ A} \checkmark$$

OPTION 3

$$\text{Current through } 4 \Omega = 2 \times 0,3 \checkmark$$

$$= 0,6 \text{ A} \checkmark$$

$$\therefore A_1 = (0,6 + 0,3) \checkmark = 0,9 \text{ A} \checkmark$$

(4)

8.2.2 Positive marking from Question 8.2.2

$$R_2 = \frac{V}{I} \checkmark$$

$$= \frac{15,6}{0,9} \checkmark$$

$$= 17,33 \Omega \checkmark$$

(3)

8.2.3 Positive marking from Question 8.2.2

$$R_p = \frac{8 \times 4}{8+4} = 2,67 \Omega \checkmark$$

$$R_t = (2,67 + 17,33) \checkmark$$

$$= 20 \Omega \checkmark$$

(3)

8.2.4 Positive marking from Questions 8.2.1 and 8.2.3

$$emf = I(R + r) \checkmark$$

$$19 \checkmark = 0,9(20 + r) \checkmark$$

$$r = 1,11 \Omega \checkmark$$

(4)

8.3.1 Decrease ✓

(1)

8.3.2 Total resistance of the circuit decreases, ✓ therefore current increases. ✓
More volts will be lost, ✓ and V_{ext} decreases ($V_{\text{ext}} = \epsilon - Ir$) ✓

(4)

[21]

QUESTION 9

- 9.1 Slip rings ✓
9.2

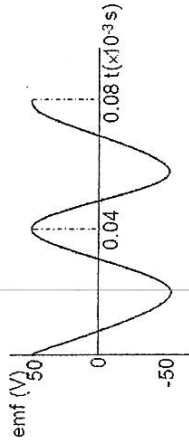

Criteria

- Starts at 50 V ✓
- Ends at 50 V ✓
- Ends at 0.08×10^{-3} s ✓
- 2 cycles ✓

(1)

- 9.3 Increase the rotation speed of the coil. ✓✓

9.4.1 $I_{rms} = \frac{I_{max}}{\sqrt{2}}$ ✓
 $I_{rms} = \frac{6.27}{\sqrt{2}}$ ✓
 $I_{rms} = 4.434$ ✓

(3)

9.4.2 **OPTION 1**

$R = \frac{V_{max}}{I_{max}}$ ✓
 $\checkmark 52.6 = \frac{V_{max}}{6.27}$ ✓
 $V_{max} = 329.80V$ ✓

OPTION 2

$I_{rms} = \frac{V_{rms}}{R}$ ✓
 $4.43 = \frac{V_{rms}}{52.6}$ ✓
 $V_{rms} = 233.018V$ ✓
 $V_{rms} = \frac{V_{max}}{\sqrt{2}}$ ✓
 $233.018 = \frac{V_{max}}{\sqrt{2}}$ ✓
 $V_{max} = 329.54V$ ✓

(5)
[15]

QUESTION 10

- 10.1 The energy of the photons of red light is greater ✓ than the work function of the metal in the photocell. ✓

OR

The frequency of red light is higher ✓ than the threshold/cut-off frequency of the metal in the photocell. ✓

- 10.2.1 Increase ✓ (1)

- 10.2.2 Stays the same ✓
 Since intensity is unchanged ✓, same number of photons reach cathode. ✓
 Therefore number of photo electrons emitted is unchanged. ✓ (4)

10.3 $E = W_0 + E_{k(max)}$ ✓
 $\frac{hc}{\lambda} = hf_0 + \frac{1}{2}mv^2$ ✓

$\frac{6.63 \times 10^{-34} \times 3 \times 10^8}{4.5 \times 10^{-7}} = 6.63 \times 10^{-34}(f_0) + \frac{1}{2}(9.11 \times 10^{-31})(5.06 \times 10^5)^2$ ✓
 $f_0 = 6.67 \times 10^{14}$ Hz ✓

(6)
[13]

GRAND TOTAL: 150

