

NORTHERN CAPE DEPARTMENT OF EDUCATION

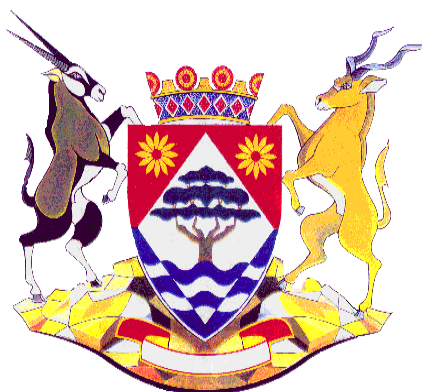

TRIAL EXAMINATION

GRADE 12

PHYSICAL SCIENCES: PHYSICS (P1)

SEPTEMBER 2015

MARKS: 150

TIME: 3 hours

This question paper consists of 15 pages and 3 data sheets.

INSTRUCTIONS AND INFORMATION

1. Write your centre number and examination number in the appropriate spaces in the ANSWER BOOK.
2. This question paper consists of TEN questions. Answer ALL the questions in the ANSWER BOOK.
3. Start EACH question on a NEW page in the ANSWER BOOK.
4. Number the answers correctly according to the numbering system used in this question paper.
5. Leave ONE line between two subsections, for example between QUESTION 2.1 and QUESTION 2.2.
6. You may use a non-programmable calculator.
7. You may use appropriate mathematical instruments.
8. You are advised to use the attached DATA SHEETS.
9. Show ALL formulae and substitutions in ALL calculations.
10. Round off your final numerical answers to a minimum of TWO decimal places.
11. Give brief motivations, discussions, et cetera where required.
12. Write neatly and legibly.

QUESTION 1: MULTIPLE-CHOICE QUESTIONS

Four options are provided as possible answers to the following questions. Each question has only ONE correct answer. Write only the letter (A – D) of the correct answer next to the question number (1.1-1.10).

- 1.1 The frictional force acting on a sliding object is ...
- A dependent of the apparent area of contact.
 - B proportional to the normal force.
 - C dependent of the velocity of motion.
 - D independent of the type of surface. (2)
- 1.2 A conservative force is a force...
- A for which the work done in moving an object between two points is dependent of the path taken.
 - B for which the work done in moving an object between two points is not always constant.
 - C for which the work done in moving an object between two points is independent of the path taken.
 - D which is equal in magnitude, but opposite in direction to a non-conservative force. (2)
- 1.3 Power can be defined as...
- A the net force acting on an object.
 - B work done by friction.
 - C the total mechanical energy of an object.
 - D the rate at which work is done. (2)

1.4 A ball is dropped from a height. Which ONE of the following velocity vs time graphs best represents the motion of the ball dropped and then bouncing vertically upwards twice?

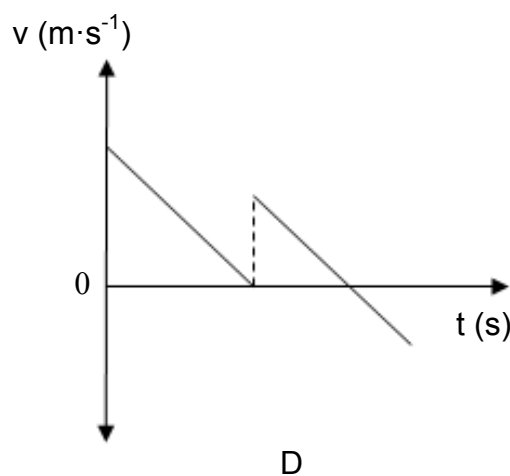
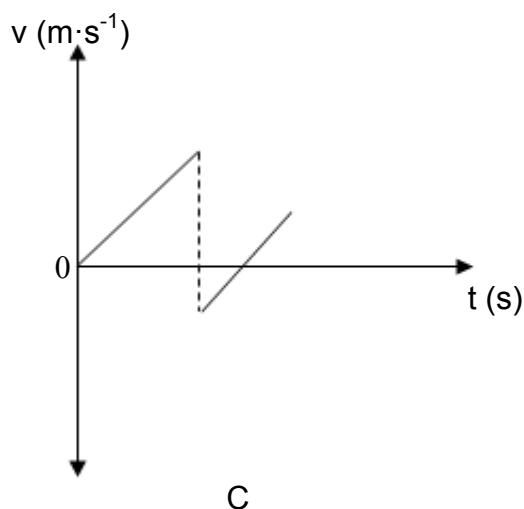
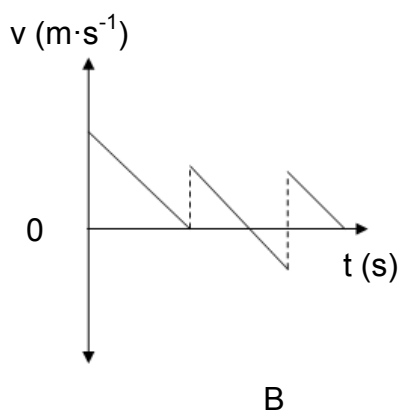
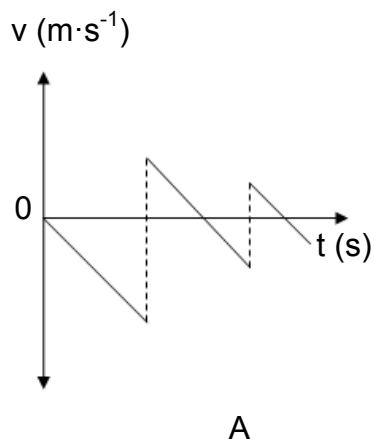

(2)

1.5 An object moves in a straight line on a ROUGH horizontal surface. If the net work done on the object is ZERO, then...

- A the object has ZERO kinetic energy.
- B the object moves at constant speed.
- C the object moves with constant acceleration.
- D there is no frictional force acting on the object.

(2)

1.6 The magnitude of the gravitational force exerted by body A on body B , separated by a distance d , is F . What will the magnitude of the gravitational force be, if the distance between the two bodies increases to $4d$?

- A $\frac{1}{16}F$
- B $\frac{1}{4}F$
- C F
- D $4F$

(2)

1.7 Car B has stopped at an intersection where the lights have gone red. Car A which has a greater mass than car B does not stop and runs into the back of car B as shown in the sketch below.

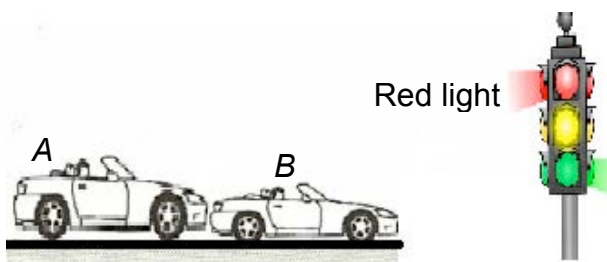

Which ONE of the following statements is true at the time of collision, about the magnitude of the forces they exert on each other?

- A B exerts a force on A, but A does not exert a force on B.
- B The magnitude of the force exerted by B on A is equal to the magnitude of the force by A on B.
- C The magnitude of the force exerted by B on A is greater than the magnitude of the force A exerts on B.
- D The magnitude of the force exerted by A on B is greater than the magnitude of the force exerted by B on A.

(2)

- 1.8 The siren of an ambulance travelling down a road at constant speed emits sound waves of 700 Hz. A man sitting next to the road notices that the pitch (frequency) of the sound changes as the ambulance moves towards him. Which ONE of the following frequency vs time graphs best shows the frequency of the sound observed (heard) by the man?

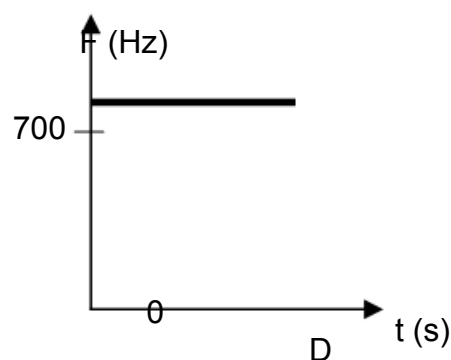
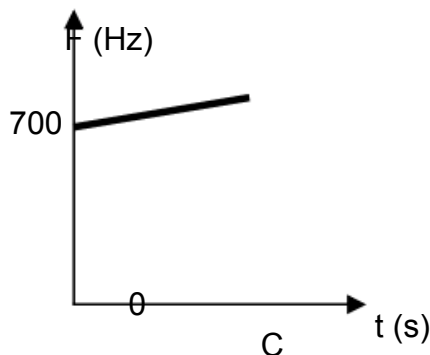
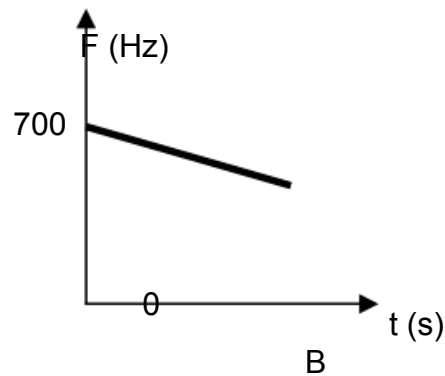
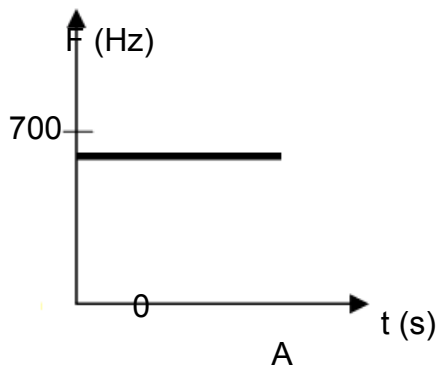

(2)

- 1.9 A learner has represented the electric field \vec{E} at points A, B, C and D due to a positive point charge Q as shown below.

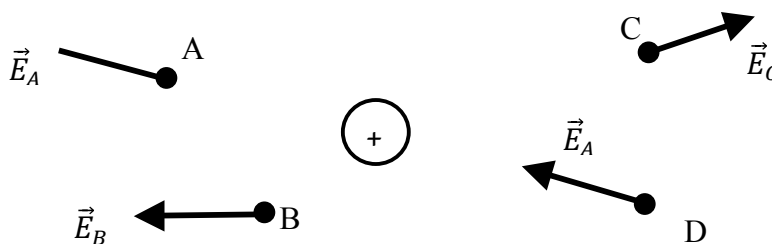

Which ONE is the correct representation?

(2)

- 1.10 The TWO resistors shown in the circuit diagram below are identical. If the reading on the ammeter A_1 is I what will the reading be on A_2 ?

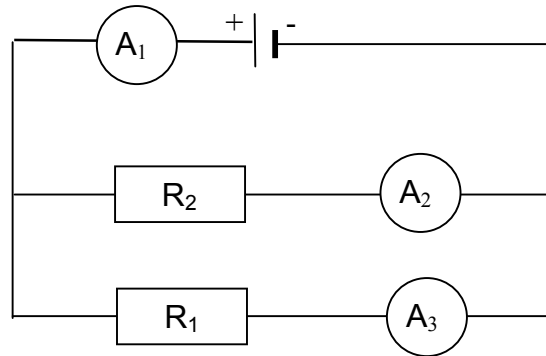

- A $\frac{1}{3} I$
B $\frac{1}{2} I$
C I
D $2I$

(2)
[20]

QUESTION 2

The picture below shows a boy pushing a lawn mower, of mass 22 kg, across a lawn at constant speed, applying a constant force at 35° .



clipsahoy.com

2.1 Define *normal force* in words. (2)

2.2 Draw a labelled free body diagram of the lawn mower to show all the forces acting on it. (4)

While the lawn mower is moving, the boy attempts to accelerate it by applying a force of 170 N.

The coefficient of kinetic friction between the mower and lawn is 0,68.

2.3 Calculate the magnitude of the kinetic frictional force between the lawn mower and the lawn. (4)

2.4 Perform a calculation to explain why the boy gets tired pushing on the lawn mower. (3)
[13]

QUESTION 3

A soccer ball of mass 430 g is moving at $20 \text{ m}\cdot\text{s}^{-1}$ horizontally towards the head of a waiting soccer player. The ball is "headed" back, in the opposite direction, along the same straight line, at $25 \text{ m}\cdot\text{s}^{-1}$. Ignore the effects of air resistance.

3.1 Define *impulse of a force* in words. (2)

3.2 Calculate the impulse exerted on the ball while the head is in contact with the ball. (3)

3.3 Using the answer in QUESTION 3.2, calculate the time for which the ball must be in contact with the head of the player in order to experience a force of magnitude 300 N. (3)

3.4 Is the collision of the soccer ball with the head of the player elastic or inelastic? Give a reason for the answer.

(2)
[10]

QUESTION 4

A boy throws a ball vertically into the air from the top of a building. The ball strikes the ground after 4,08 s. The velocity-time graph below represents the entire motion of the ball. Ignore the effects of air friction.

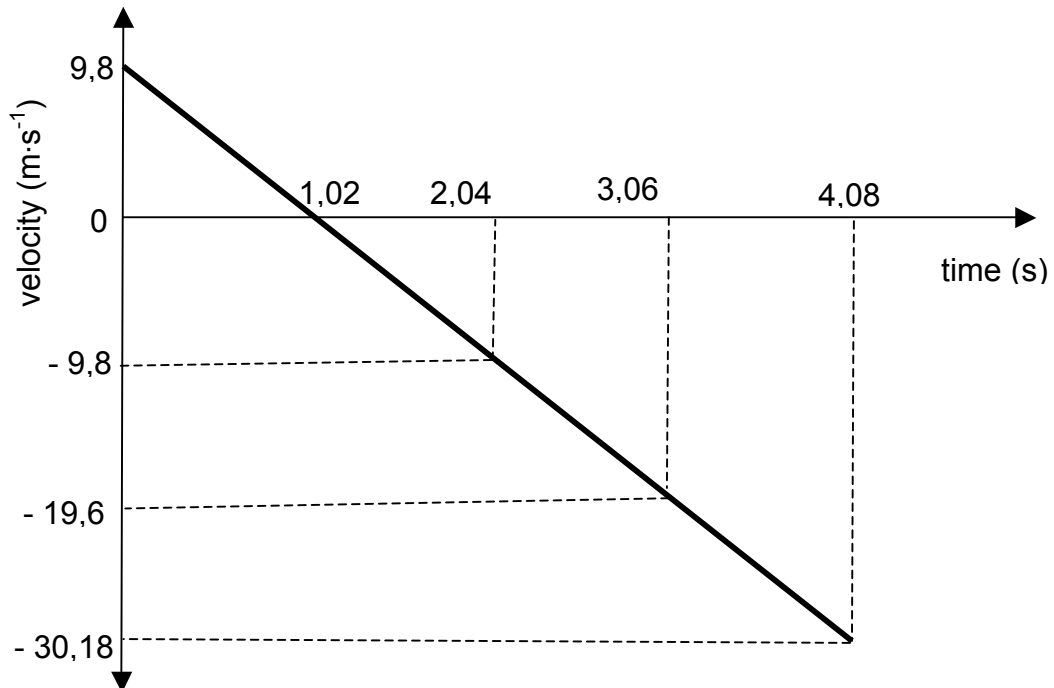

- 4.1 Explain what is meant by a *projectile*. (2)
- 4.2 What is the acceleration of the ball at time 1,02 s? (2)
- 4.3 Calculate the displacement of the ball. (4)
- 4.4 Sketch a position versus time graph for the entire motion of the ball. Indicate the following on the graph:
- Initial position
 - Maximum height
 - Final position
 - Time (t) values

(4)
[12]

QUESTION 5

A block of mass 6 kg slides to the right with a constant velocity of $8\text{ m}\cdot\text{s}^{-1}$ on a horizontal, frictionless surface. It collides with a stationary block of mass 5 kg. The blocks move together to the right as a single system along the same surface. Refer to the diagram below.

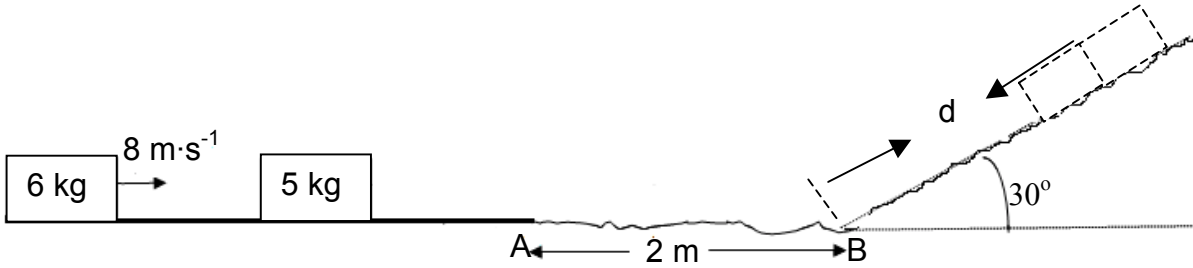

- 5.1 State the *law of conservation of linear momentum* in words. (2)
- 5.2 Calculate the velocity of the system of two blocks immediately after the collision. (4)

The block system continues moving with the same common velocity to point **A**, then continues over the rough section **AB**, a distance of 2 m passing point B at $1,5\text{ m}\cdot\text{s}^{-1}$. The system continues up the rough ramp, finally coming to a stop after moving a distance d as shown in the diagram.

- 5.3 Use energy considerations ONLY to calculate the coefficient of sliding friction between the block system and the surface over the 2 m stretch. (5)
- 5.4 The system of two blocks slides up the rough ramp with the same coefficient of friction until they come to rest after covering a distance " d ".
 - 5.4.1 Use NEWTON'S SECOND LAW of motion to calculate the distance d . (7)
 - 5.4.2 How would the answer to QUESTION 5.4.1 change if the angle of inclination is less than 30° ? Write only INCREASES, DECREASES or REMAINS THE SAME. Give a reason for the answer. (2)

[20]

QUESTION 6

The siren of an ambulance emits sound of frequency 930 Hz as the ambulance approaches a stationary observer. The observer detects a frequency of 1000 Hz. Take the speed of sound in air as $340 \text{ m}\cdot\text{s}^{-1}$

- 6.1 State *Doppler effect* in words. (2)
- 6.2 Calculate the speed with which the ambulance approaches the observer. (5)
- 6.3 The ambulance is moving away from the observer. What effect will this have on the wavelength of the sound heard by the observer? Write down only INCREASES, DECREASES or REMAINS THE SAME. Give a reason for the answer. (2)
- 6.4 The Doppler effect could be used to explain the motion of stars and other heavenly bodies in our universe.
The two diagrams below represent the absorption spectra of a gas.
Diagram 1 represents the absorption lines in the optical spectrum of the Sun.
Diagram 2 represents the absorption lines in the optical spectrum of a supercluster of distant galaxies.

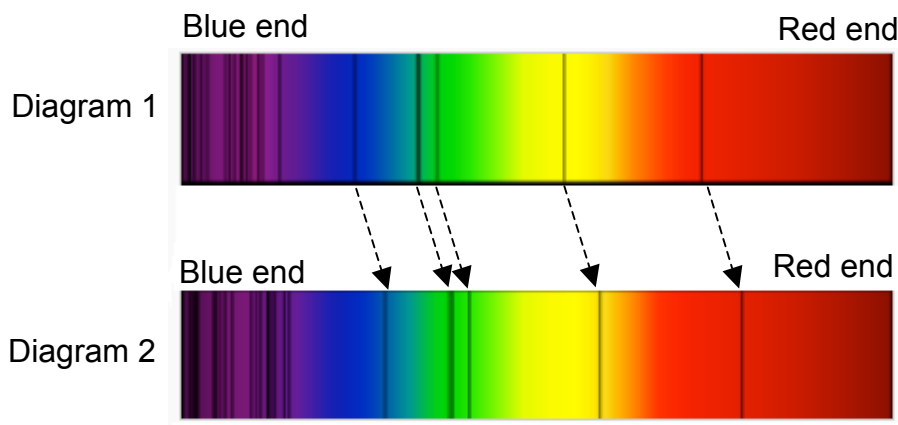

- 6.4.1 Are the stars moving *towards* or *away from* the Sun? Explain the answer by referring to the shifts in the spectral lines in the two diagrams above. (2)
- 6.4.2 From the comparison of the two diagrams above, what conclusion can be made about the Universe? (1)

[12]

QUESTION 7

Two point charges $q_1 = +2,0 \mu\text{C}$ and $q_2 = -2,0 \mu\text{C}$ 1 m apart, are placed in vacuum as shown in the sketch below.

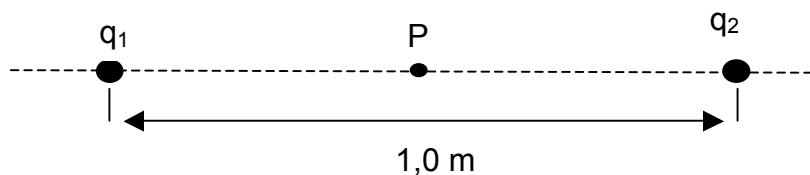

- 7.1 Define *electric field at a point* in words. (2)
- 7.2 Draw the electric field pattern due to the two point charges. (2)
- 7.3 Calculate the electric field at the midpoint between charges q_1 and q_2 . (6)

Point charge q_2 is now replaced by a $+6 \mu\text{C}$ charge as shown in the sketch below.

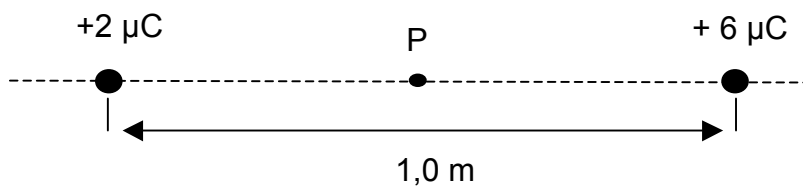

- 7.4. Determine where a negative point charge ($-q_3$) must be placed so that it experiences a zero net force. (6)

[16]

QUESTION 8

In the circuit diagram below the emf of the battery is 6 V and its internal resistance is $0,10 \Omega$. The resistance R is UNKNOWN.

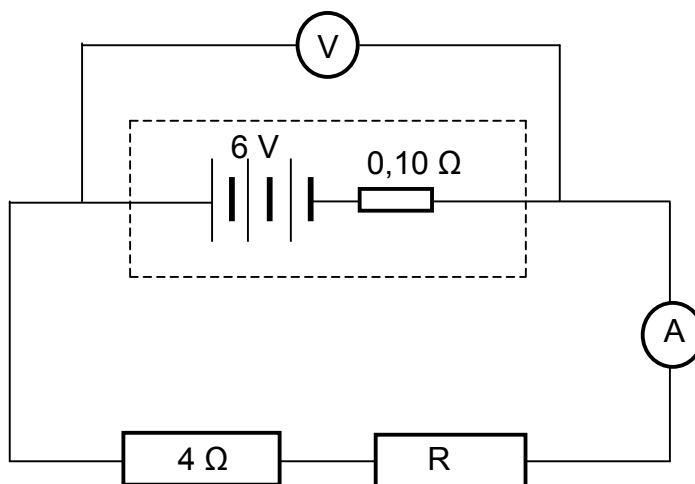

- 8.1 Explain the term *internal resistance*. (2)
- 8.2 Write down an equation for the terminal potential difference using the values given. (2)
- 8.3 Draw a sketch graph of terminal potential difference versus current. Indicate the following in the graph: (3)
- The value of the emf
 - Current at which terminal potential difference is zero.
- 8.4 The energy dissipated in 4Ω resistance is 40 J and the energy dissipated in resistance R is 60 J.
- Calculate the:
- 8.4.1 Resistance R (4)
- 8.4.2 Total current in the circuit (3)
- 8.4.3 Reading of the voltmeter (3)
- 8.5 A 7Ω resistor is now connected in parallel to the 4Ω resistor. How will this action affect the reading of the voltmeter? Write down only INCREASES, DECREASES or REMAINS THE SAME. Briefly explain the answer. (4)

[21]

QUESTION 9

The diagram below represents an electrical machine and P is a split ring commutator.

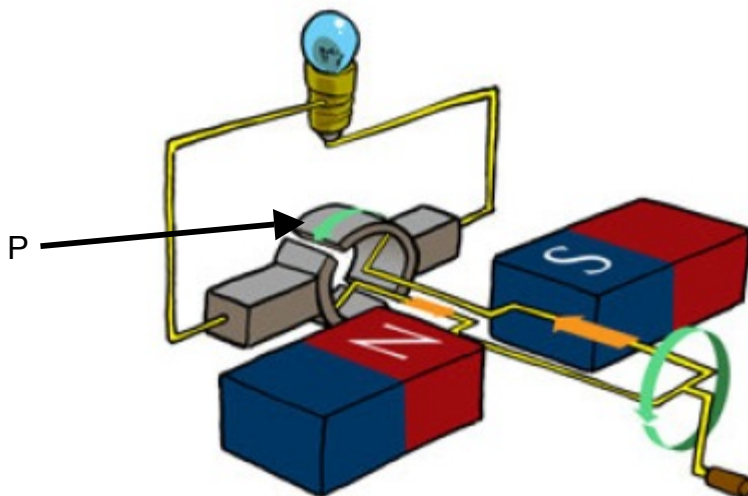

- 9.1 Identify the type of electrical machine and write down the energy conversion that takes place in this electrical machine. (2)
- 9.2 Explain the function of the component P. (2)
- 9.3 The split ring commutator is replaced by slip rings. Which ONE of the following voltage-time graphs (Graph A or Graph B) corresponds with the above change?

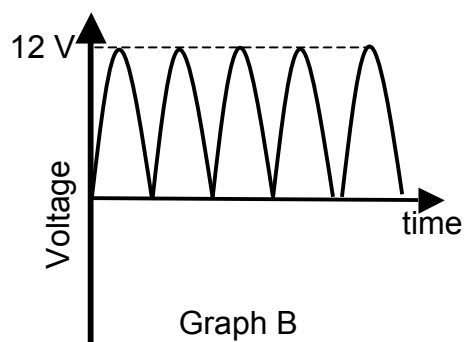
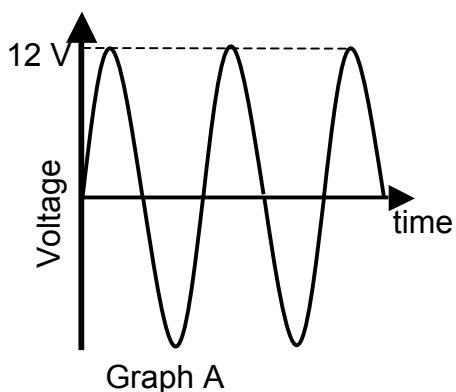

Explain the answer. (3)

- 9.4 The light bulb shown in the circuit dissipates energy of 6 J per second. An identical light bulb is connected in parallel to it. Calculate the rms current in the circuit under the new conditions. Assume the emf remains unchanged. (5)
- [12]**

QUESTION 10

The relationship between the maximum kinetic energy of ejected photo-electrons and the frequency of radiation is being investigated.

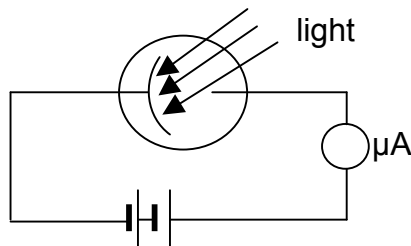

Light of different frequencies are incident on the aluminium cathode of a photo-cell and the kinetic energy of the ejected photo-electrons are determined. The graph below is drawn according to the data collected from the investigation.

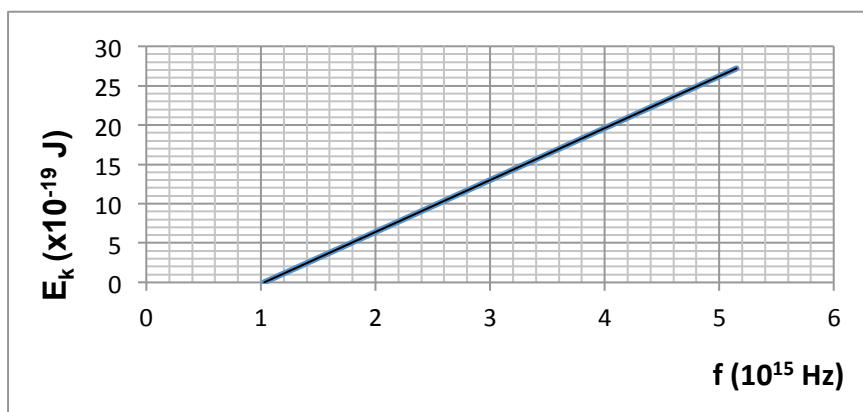

- 10.1 Write down an investigative question for this investigation. (2)
- 10.2 Write down the:
 - 10.2.1 independent variable (1)
 - 10.2.2 controlled variable (1)
- 10.3 Write down a possible conclusion for this investigation. (2)

Aluminium is now replaced by another metal **X** with work function 8×10^{-19} J. The incident light has a wavelength of 200 nm.

- 10.4 Calculate the maximum kinetic energy of the electrons ejected from the surface of the metal. (5)
- 10.5 The intensity of the incident light is now increased. How will this affect the maximum kinetic energy calculated in QUESTION 10.4? Give a reason for the answer. (2)
- 10.6 The wavelength of the incident light is now increased keeping the intensity constant. How will this affect the maximum kinetic energy calculated in QUESTION 10.4? Write down only INCREASES, DECREASES or REMAINS THE SAME. (1)

[14]

TOTAL MARKS: 150

**DATA FOR PHYSICAL SCIENCES GRADE 12
PAPER 1 (PHYSICS)**

**GEGEWENS VIR FISIESTE WETENSKAPPE GRAAD 12
VRAESTEL 1 (FISIKA)**

TABLE 1: PHYSICAL CONSTANTS/TABEL 1: FISIESTE KONSTANTES

NAME/NAAM	SYMBOL/SIMBOOL	VALUE/WAARDE
Acceleration due to gravity <i>Swaartekragversnelling</i>	g	9,8 m·s ⁻²
Universal gravitational constant <i>Universele gravitasiekonstant</i>	G	6,67 x 10 ⁻¹¹ N·m ² ·kg ⁻²
Speed of light in a vacuum <i>Spoed van lig in 'n vakuum</i>	c	3,0 x 10 ⁸ m·s ⁻¹
Planck's constant <i>Planck se konstante</i>	h	6,63 x 10 ⁻³⁴ J·s
Coulomb's constant <i>Coulomb se konstante</i>	k	9,0 x 10 ⁹ N·m ² ·C ⁻²
Charge on electron <i>Lading op elektron</i>	e	-1,6 x 10 ⁻¹⁹ C
Electron mass <i>Elektronmassa</i>	m _e	9,11 x 10 ⁻³¹ kg

TABLE 2: FORMULAE/TABEL 2: FORMULES**MOTION/BEWEGING**

$v_f = v_i + a \Delta t$	$\Delta x = v_i \Delta t + \frac{1}{2} a \Delta t^2$ or/of $\Delta y = v_i \Delta t + \frac{1}{2} a \Delta t^2$
$v_f^2 = v_i^2 + 2a\Delta x$ or/of $v_f^2 = v_i^2 + 2a\Delta y$	$\Delta x = \left(\frac{v_i + v_f}{2} \right) \Delta t$ or/of $\Delta y = \left(\frac{v_i + v_f}{2} \right) \Delta t$

FORCE/KRAG

$F_{\text{net}} = ma$	$p = mv$
$F_{\text{net}} \Delta t = \Delta p$ $\Delta p = mv_f - mv_i$	$w = mg$

WORK, ENERGY AND POWER/ARBEID, ENERGIE EN DRYWING

$W = F \Delta x \cos \theta$	$U = mgh$ or/of $E_p = mgh$
$K = \frac{1}{2} mv^2$ or/of $E_k = \frac{1}{2} mv^2$	$W_{\text{net}} = \Delta K$ or/of $W_{\text{net}} = \Delta E_k$ $\Delta K = K_f - K_i$ or/of $\Delta E_k = E_{kf} - E_{ki}$
$W_{\text{nc}} = \Delta K + \Delta U$ or/of $W_{\text{nc}} = \Delta E_k + \Delta E_p$	$P = \frac{W}{\Delta t}$
$P = Fv$	

WAVES, SOUND AND LIGHT/GOLWE, KLANK EN LIG

$v = f \lambda$	$T = \frac{1}{f}$
$f_L = \frac{v \pm v_L}{v \pm v_s} f_s$ $f_L = \frac{v \pm v_L}{v \pm v_b} f_b$	$E = hf$ or/of $E = h \frac{c}{\lambda}$
$E = W_o + E_k$ where/waar $E = hf$ and/en $W_o = hf_o$ and/en $E_k = \frac{1}{2} mv^2$	

ELECTROSTATICS/ELEKTROSTATIKA

$F = \frac{kQ_1 Q_2}{r^2}$	$E = \frac{kQ}{r^2}$
$E = \frac{V}{d}$	$E = \frac{F}{q}$

$V = \frac{W}{q}$	
-------------------	--

ELECTRIC CIRCUITS/ELEKTRIESE STROOMBANE

$R = \frac{V}{I}$	emf (ϵ) = I(R + r) emk (ϵ) = I(R + r)
$R_s = R_1 + R_2 + \dots$ $\frac{1}{R_p} = \frac{1}{R_1} + \frac{1}{R_2} + \dots$	$q = I \Delta t$
$W = Vq$ $W = VI \Delta t$ $W = I^2 R \Delta t$ $W = \frac{V^2 \Delta t}{R}$	$P = \frac{W}{\Delta t}$ $P = VI$ $P = I^2 R$ $P = \frac{V^2}{R}$

ALTERNATING CURRENT/WISSELSTROOM

$I_{\text{rms}} = \frac{I_{\text{max}}}{\sqrt{2}}$ / $I_{\text{wgk}} = \frac{I_{\text{maks}}}{\sqrt{2}}$	$P_{\text{average}} = V_{\text{rms}} I_{\text{rms}}$ / $P_{\text{gemiddeld}} = V_{\text{wgk}} I_{\text{wgk}}$
$V_{\text{rms}} = \frac{V_{\text{max}}}{\sqrt{2}}$ / $V_{\text{wgk}} = \frac{V_{\text{maks}}}{\sqrt{2}}$	$P_{\text{average}} = I_{\text{rms}}^2 R$ / $P_{\text{gemiddeld}} = I_{\text{wgk}}^2 R$
	$P_{\text{average}} = \frac{V_{\text{rms}}^2}{R}$ / $P_{\text{gemiddeld}} = \frac{V_{\text{wgk}}^2}{R}$