



**LIMPOPO**  
PROVINCIAL GOVERNMENT  
REPUBLIC OF SOUTH AFRICA

**DEPARTMENT OF EDUCATION**

**NATIONAL  
SENIOR CERTIFICATE**

**GRADE 12**

**PHYSICAL SCIENCES: PHYSICS (P1)**

**PREPARATORY EXAMINATIONS  
SEPTEMBER 2016**

**MARKS: 150**

**TIME: 3 hours**

**This question paper consists of 16 pages and 3 data sheets.**

**INSTRUCTIONS AND INFORMATION**

1. Write your NAME in the appropriate space on the ANSWER BOOK.
2. This question paper consists of ELEVEN questions. Answer ALL the questions in the ANSWER BOOK.
3. Start EACH question on a NEW page in the ANSWER BOOK.
4. Number the answers correctly according to the numbering system used in the question paper.
5. Leave ONE line between two sub-questions, for example between QUESTION 2.1 and QUESTION 2.2.
6. You may use a non-programmable calculator.
7. You may use appropriate mathematical instruments.
8. You are advised to use the attached DATA SHEETS.
9. Show ALL formulae and substitutions in ALL calculations.
10. Round off your FINAL numerical answers to a minimum of TWO decimal places.
11. Give brief motivations, discussions, et cetera where required.
12. Write neatly and legibly.

**QUESTION 1: MULTIPLE-CHOICE QUESTIONS**

Four options are provided as possible answers to the following questions. Each question has only ONE correct answer. Write only the letter (A-D) of the answer next to the question number (1.1 – 1.10) in the ANSWER BOOK.

1.1 A learner is sitting on a chair. According to Newton's Third Law of Motion, the reaction force to the learner's weight is the force of the ...

- A learner on the chair.
- B chair on the learner.
- C earth on the learner.
- D learner on the earth.

(2)

1.2 An object of WEIGHT  $mg$  hangs from a light cord passing over a light, frictionless pulley, as shown in the diagram below.

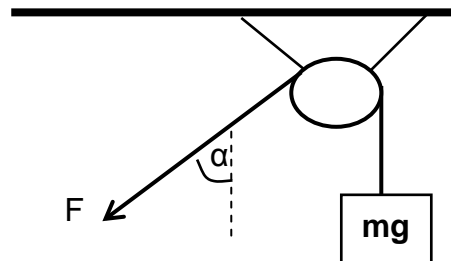

What constant force  $F$ , applied on the end of the cord, as shown, would hold the object at **REST**?

- A  $F = mg$
- B  $F = mg \times \sin \alpha$
- C  $F = \frac{1}{2} mg$
- D  $F = mg \times \cos \alpha$

(2)

- 1.3 Two fairly large asteroids, **X** and **Y**, have masses  $M$  and  $2M$  respectively. They move towards each.

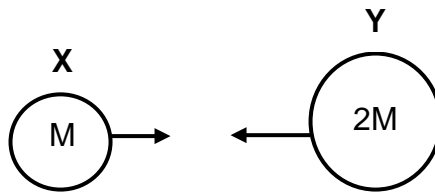

If the magnitude of the acceleration of asteroid **X** is  $a$ , then magnitude of the acceleration of asteroid **Y** would be ...

- A  $\frac{1}{4} a$   
 B  $a$   
 C  $\frac{1}{2} a$   
 D  $2 a$

(2)

- 1.4 A car travels along a straight level road with constant acceleration. Which **ONE** of the following power (**P**) versus velocity (**v**) graphs best represents the motion of the car?

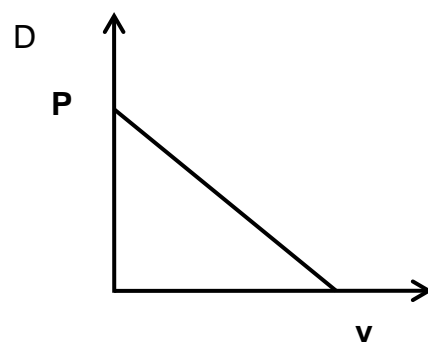
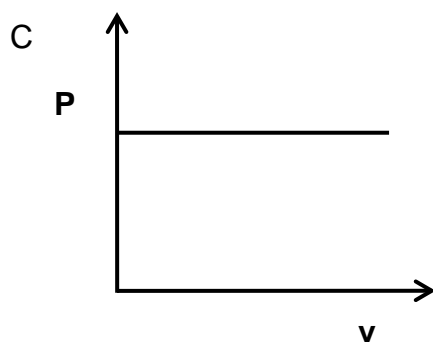
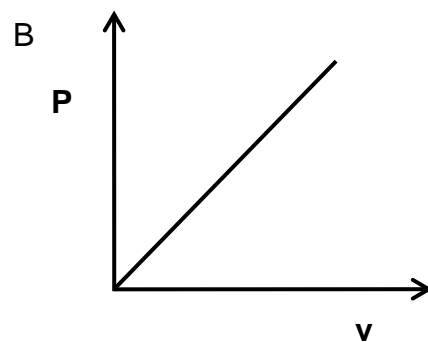
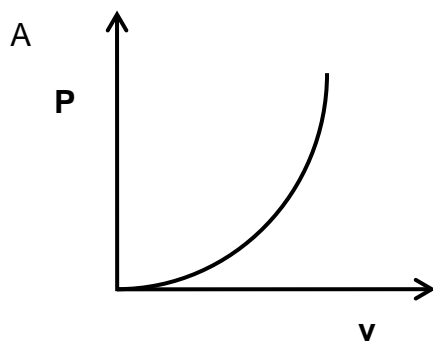

(2)

- 1.5 A body moving at a constant velocity has kinetic energy  $E$  and momentum  $p$ . The velocity of the body is doubled. Which ONE of the following correctly gives the magnitudes of both the kinetic energy and momentum?

	<b>Kinetic Energy</b>	<b>Momentum</b>
A	2 $E$	2 $p$
B	4 $E$	4 $p$
C	4 $E$	2 $p$
D	2 $E$	4 $p$

(2)

- 1.6 A stationary ambulance has its siren on. A girl moves away from the ambulance with a constant velocity  $v_x$ . The ratio of the actual frequency of the siren of the ambulance to the apparent frequency as heard by the girl is 1,25.

The girl now stands still and the ambulance moves away from her with the same velocity  $v_x$ . What will be the ratio of the actual frequency of the siren to the apparent frequency as heard by the girl?

- A 1,2  
B 1,25  
C 1,4  
D 1,5

(2)

- 1.7 A section of a circuit is represented below. A potential difference  $V$  is applied across points **S** and **K**.

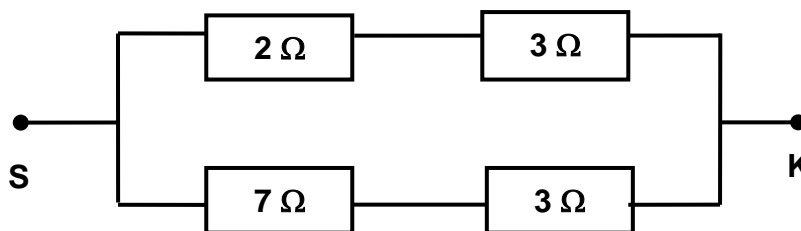

Which ONE of the following gives the current in the  $7\ \Omega$  resistor?

- A  $\frac{V}{3}$   
 B  $\frac{V}{5}$   
 C  $\frac{V}{7}$   
 D  $\frac{V}{10}$

(2)

- 1.8 Three charged spheres, **P**, **Q** and **R** are placed as shown below. **Q** is POSITIVELY charged.

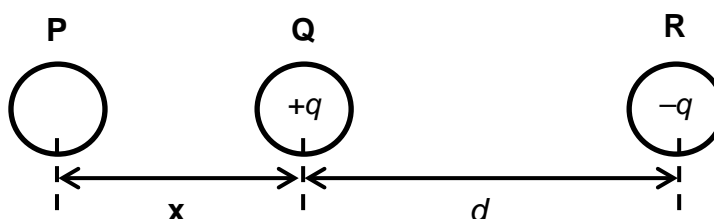

Spheres **Q** and **R** are a distance  $d$  from each other and carry charges of  $+q$  and  $-q$  respectively.

The charge on sphere **P** is NINE times greater than that on sphere **Q**. Which ONE of the following is correct for the charge on sphere **P** and the distance  $x$  between **P** and **Q** so that charge **Q** remains at **REST**?

- |   | <b>charge</b> | <b>distance <math>x</math></b> |
|---|---------------|--------------------------------|
| A | positive      | $4,5\ d$                       |
| B | positive      | $3\ d$                         |
| C | negative      | $4,5\ d$                       |
| D | negative      | $3\ d$                         |

(2)

- 1.9 In the diagram below a straight current carrying conductor, C, lies between two magnets A and B. The conductor experiences a downward force when placed between the two magnets.

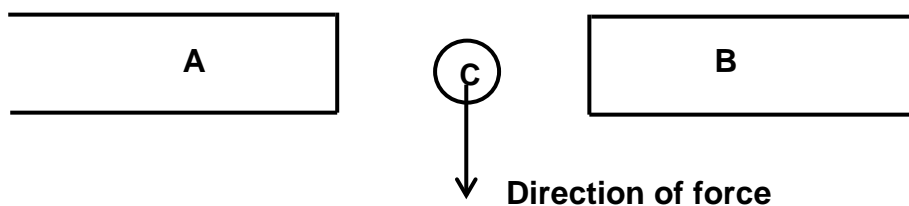

Which ONE of the following combinations is correct?

	Direction of the magnetic field due to A and B	Direction of the current in C
A	B to A	into the paper, away from the reader
B	B to A	out of the paper, towards the reader
C	A to B	out of the paper, towards the reader
D	A to B	into the paper, away from the reader

(2)

- 1.10 A graph of the kinetic energy of photons of light versus the frequency of the photons is shown below.

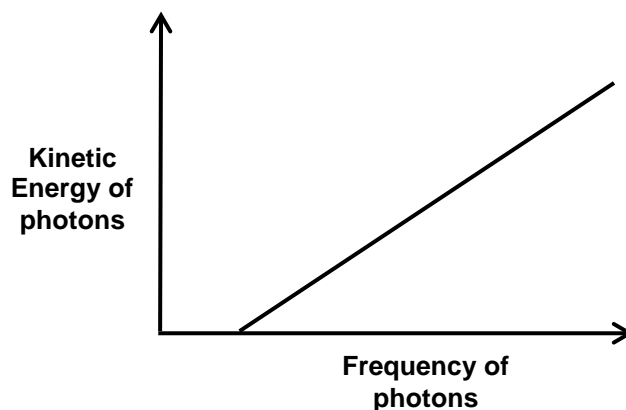

What is represented by the gradient of the above graph?

- A Plank's Constant
- B threshold frequency
- C speed of light
- D mass of the photon

(2)

[20]

**QUESTION 2 (Start on a new page)**

- 2.1 A 4 kg trolley is at rest on a rough inclined surface, which makes an angle of  $30^\circ$  with the horizontal. A constant force is applied, causing the trolley to accelerate up the incline for 2m at  $0,43 \text{ m}\cdot\text{s}^{-2}$ . (Ignore the rotation effects of the wheels and air friction.)

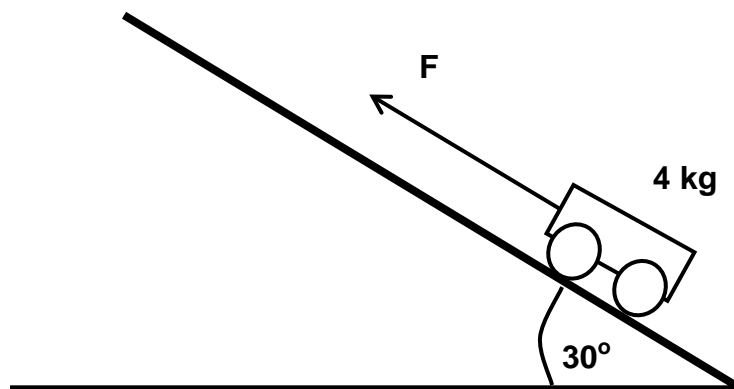

- 2.1.1 State, in words, Newton's Second Law of Motion. (2)
- 2.1.2 Draw a labelled free body diagram showing ALL the forces acting on the trolley as it moves up the slope. (4)
- 2.1.3 If the coefficient of kinetic friction along the incline  $\mu_k$  is 0,2, calculate the:
- (a) Frictional force on the trolley as it moves up the slope (3)
- (b) Applied force F (5)
- 2.2 A spaceship, mass 2 000 kg, is moving towards Earth. Calculate the magnitude of the gravitational force that the spaceship will experience when it is 100 km above the Earth's surface. (4)

**[18]**



**QUESTION 3 (Start on a new page)**

The velocity – time graph below shows the motion of a ball that is thrown vertically upwards from the balcony of a building. It takes 0,5 s for the ball to reach the highest point above the balcony, after which it falls past the balcony and strikes the ground. Ignore the effects of friction.

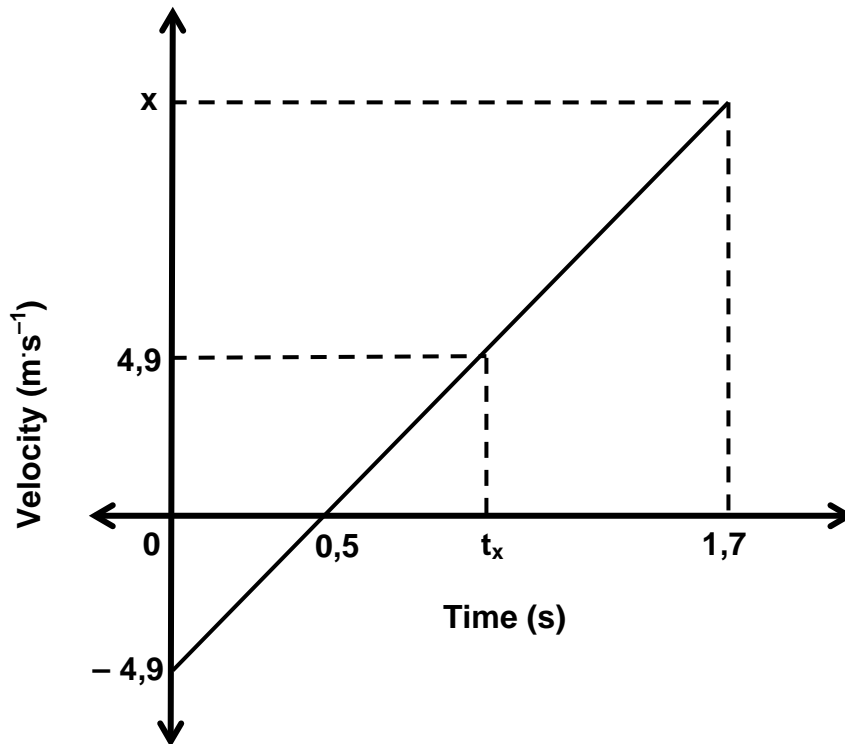

- 3.1 State the numerical value of:
- 3.1.1 The gradient of the above velocity – time graph  
Provide a reason for your answer. (2)
- 3.1.2 Time,  $t_x$ , as shown on the graph. (1)
- 3.2 Use ONLY the graph (and NOT equations of motion) to determine the maximum height the ball reaches above the balcony. (3)
- 3.3 Calculate, using equations of motions and data from the graph, the:
- 3.3.1 Velocity,  $x$ , with which the ball strikes the ground (3)
- 3.3.2 Height of the balcony above the ground (3)
- 3.4 Sketch an acceleration versus time graph for the motion of the ball. (2)

**[14]**

**QUESTION 4 (Start on a new page)**

A block of mass 800 g moves under the influence of a force of 0,30 N. When the block reaches a velocity of  $1,2 \text{ m}\cdot\text{s}^{-1}$ , it enters a rough surface. The block experiences a constant frictional force of 0,86 N as it moves from point P to point Q as shown below causing its speed to decrease to  $0,2 \text{ m}\cdot\text{s}^{-1}$  after a displacement,  $\Delta x$ .

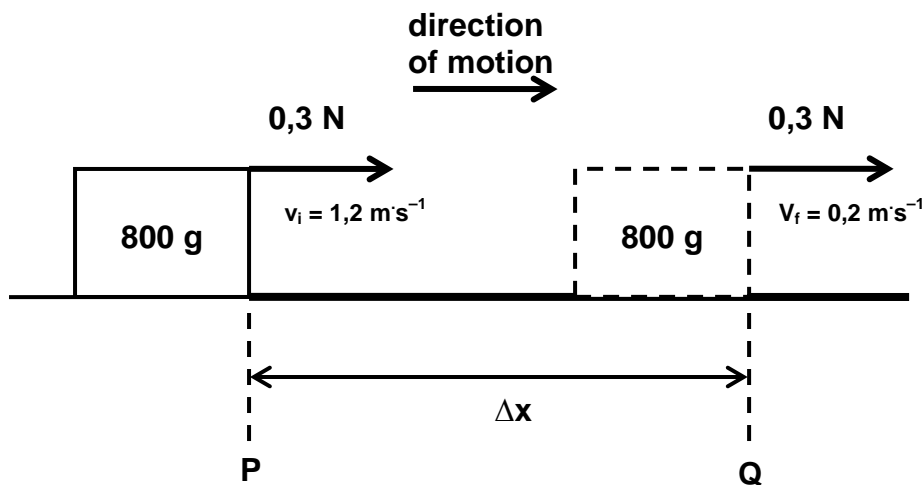

- 4.1 Draw a labelled free body diagram showing all the forces acting on the block as it moves across the rough surface. (4)
- 4.2 Determine the net force acting on the block as it moves across the surface. (3)
- 4.3 State the Work Energy Theorem in words. (2)
- 4.4 Use **Energy Principles** to calculate the displacement,  $\Delta x$ , of the block. (4)
- 4.5 NAME **ONE** non – conservative force acting on the block as it moves across the surface. (1)

**[14]**

**QUESTION 5 (Start on a new page)**

A cannon has a mass of 1 250 kg and is 1 000 times heavier than the cannon ball that it fires during a routine training exercise. The cannon ball leaves the barrel at a horizontal velocity of  $80 \text{ m s}^{-1}$ .

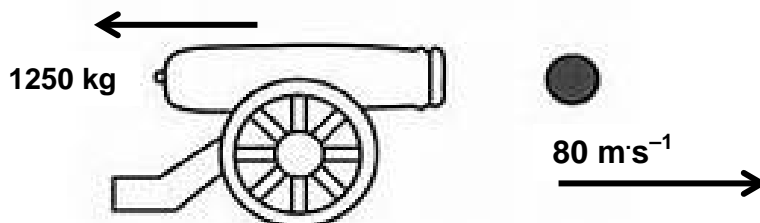

The cannon comes to **rest** 1 second after being fired.

- 5.1 Define, in words, the term *impulse*. (2)
- 5.2 Calculate the:
- 5.2.1 Maximum velocity with which the cannon moves backwards (5)
- 5.2.2 Magnitude of the average net force that causes the cannon to come to rest (4)

**[11]****QUESTION 6 (Start on a new page)**

- 6.1 A bird, flying at a constant speed, emits sounds with a frequency of 90 Hz. A stationary observer hears the sounds from the bird at 88 Hz.
- 6.1.1 State the Doppler Effect in words. (2)
- 6.1.2 Is the bird moving TOWARDS or AWAY from the observer? (1)
- 6.1.3 Calculate the speed with which the bird is flying. (5)
- 6.2 The velocities of galaxies relative to the earth can be determined by studying the red shift observed in their spectrums. The table below shows the velocities of three galaxies, **D**, **E** and **F**, relative to the earth.

Galaxies	D	E	F
Speed ( $\times 10^7$ ) $\text{m s}^{-1}$	0,15	1,52	2,44

- 6.2.1 What is meant by the term '*red shift*'? (2)
- 6.2.2 State the type of spectrum observed for the different galaxies. (1)
- 6.2.3 Which galaxy **D**, **E** or **F** shows the greatest red shift? Give a reason for your answer. (2)

**[13]**

**QUESTION 7 (Start on a new page)**

Two very small identical spheres,  $Q_1$  and  $Q_2$ , with the SAME NEGATIVE charge are placed on insulating stands with their centres 6 mm apart. The magnitude of the electrostatic force that  $Q_1$  exerts on  $Q_2$  is  $4 \times 10^{-3}$  N. Point  $X$  is a distance  $d$  east of  $Q_2$ , as shown below.

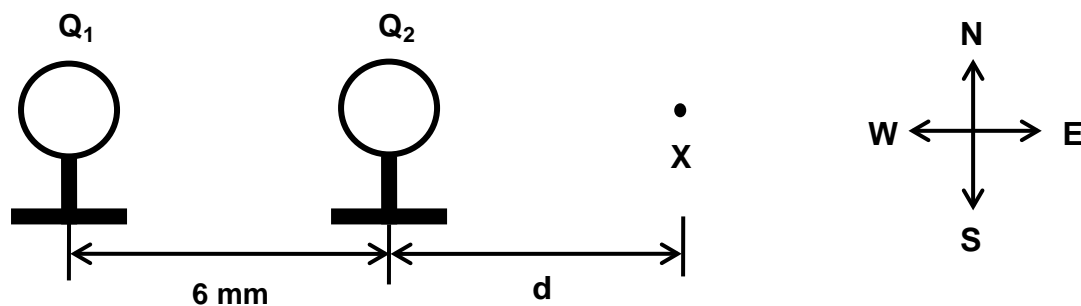

- 7.1 Draw the resultant electric field pattern due to charges  $Q_1$  and  $Q_2$ . (3)
- 7.2 State, in words, Coulomb's Law of Electrostatics. (2)
- 7.3 Calculate the magnitude of the charge on  $Q_1$ . (4)
- 7.4 The electric field at point  $X$ , due to  $Q_1$  ONLY, is  $4,44 \times 10^{-5} \text{ N}\cdot\text{C}^{-1}$  west. Calculate the magnitude of distance  $d$ . (5)

**[14]**

**QUESTION 8 (Start on a new page)**

A battery with an **unknown** emf and internal resistance of  $5\ \Omega$  is connected to a  $43\ \Omega$  lamp and other resistors as shown in the circuit below. Voltmeter  $V_1$  is connected across the battery and voltmeter  $V_2$  is connected across the open switch **S**. Ignore the resistance of the ammeter and connecting wires.

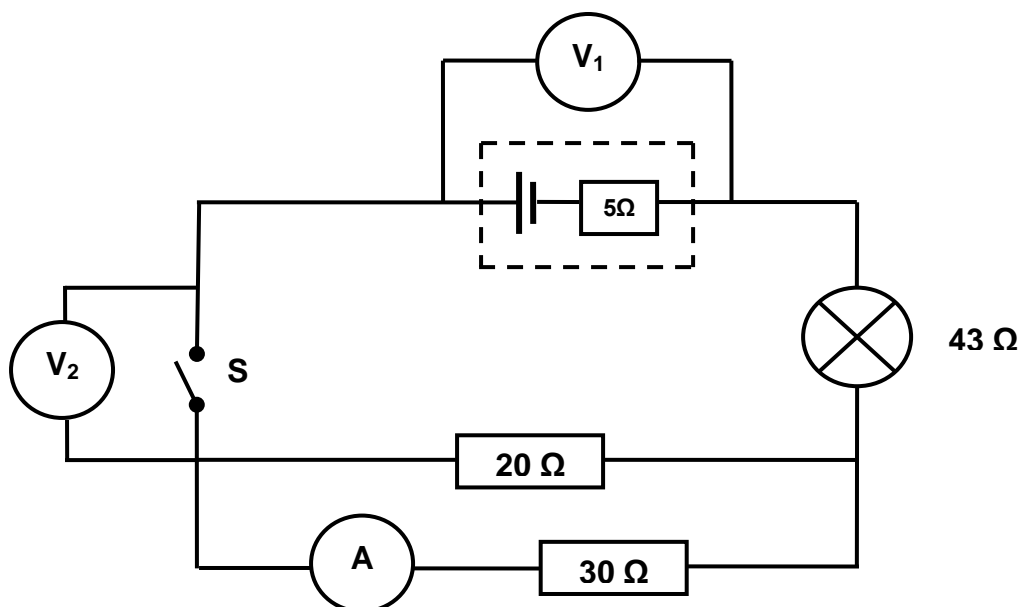

- 8.1 Define, in words, the term *emf*. (2)
- 8.2 The reading on  $V_1$  **decreases** by  $4,5\ \text{V}$  when switch **S** is closed.
- 8.2.1 What causes the decrease in the voltmeter,  $V_1$ , reading? (1)
- 8.2.2 What is the reading on  $V_2$  when switch **S** is closed? (1)
- 8.2.3 Calculate the emf of the battery. (7)
- 8.2.4 Calculate the reading on the ammeter. (3)
- 8.3 Would the power of the bulb **INCREASE, DECREASE** or **REMAIN THE SAME** when the  $20\ \Omega$  resistor is removed? Explain your answer. (2)

**[17]**

**QUESTION 9 (Start on a new page)**

A learner sets up a circuit to determine the emf ( $\mathcal{E}$ ) and internal resistance ( $r$ ) of a battery. The learner obtained the following graph from the data of the investigation.

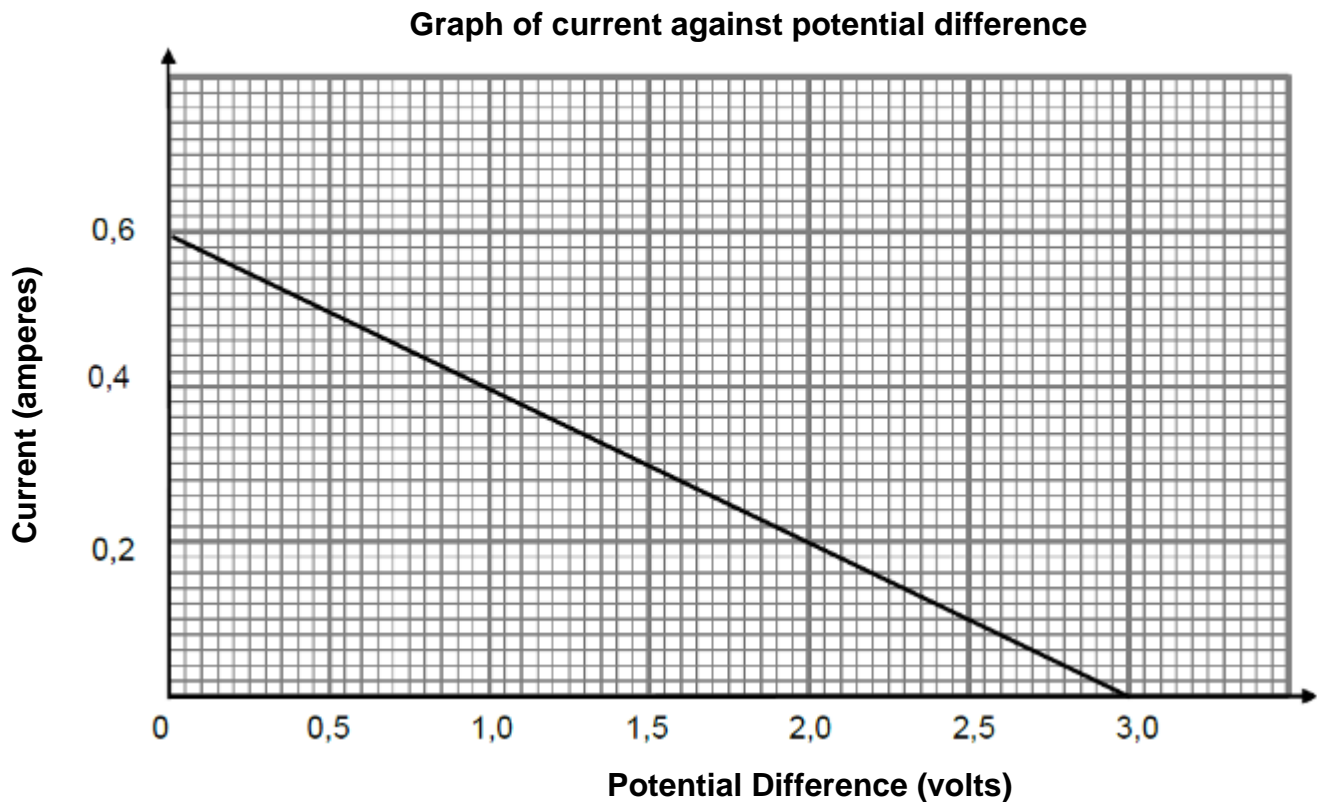

- 9.1 Define, in words, the term *internal resistance*. (2)
- 9.2 Using the **graph ONLY** determine the value of the following:
- 9.2.1 Emf ( $\mathcal{E}$ ) of the battery (1)
- 9.2.2 'Lost' volts when the current in the circuit is 0,2 A (2)
- 9.2.3 Internal resistance of the battery (3)

**[8]**

**QUESTION 10 (Start on a new page)**

10.1 The diagram below represents a simplified sketch of a DC motor.

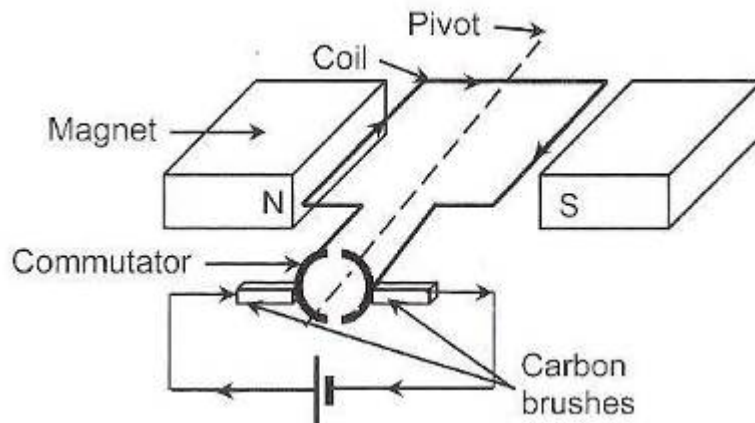

10.1.1 Name the component which ensures continuous rotation of the coil of the above motor. (1)

10.1.2 Name the part of the motor which becomes an electromagnet when the motor is in operation. (1)

10.2 The electricity supply to a house decreases from 240 V to 200 V **rms**.

10.2.1 Calculate the peak voltage during the power decrease. (3)

10.2.2 An electric iron dissipates 2 200 W when it is operated on an rms voltage of 240 V. Calculate the power at which it will operate during the power decrease. (4)

**[9]**

**QUESTION 11 (Start on a new page)**

A learner conducts an experiment to determine which metal(s) will release electrons when green light of WAVELENGTH 510 nm is shone on it. The table below shows the different metals used in the experiment with their respective work functions.

Metal	Work Function (J)
Gold	$8,16 \times 10^{-19}$
Aluminium	$6,88 \times 10^{-19}$
Sodium	$4,32 \times 10^{-19}$
Caesium	$3,36 \times 10^{-19}$

- 11.1 Calculate the energy of a photon of green light. (4)
- 11.2 Using the data from the above table, identify the metal(s) which will release photoelectrons when green light is shone onto their surfaces. Explain your answer. (2)
- 11.3 Calculate the maximum kinetic energy of a photoelectron when green light shines onto the metal in question 11.2. (3)
- 11.4 The intensity of the green light is DOUBLED. State the effect that this has on each of the following:  
(Choose from **INCREASES**, **DECREASES** or **REMAINS THE SAME**)
- 11.4.1 The work function of each metal (1)
- 11.4.2 The maximum kinetic energy of each emitted photoelectron (1)
- 11.4.3 The energy of each photon of green light (1)

**[12]****Grand Total: 150**



**DATA FOR PHYSICAL SCIENCES GRADE 12  
PAPER 1 (PHYSICS)**

**GEGEWENS VIR FISIESTE WETENSAPPE GRAAD 12  
VRAESTEL 1 (FISIKA)**

**TABLE 1: PHYSICAL CONSTANTS/TABEL 1: FISIESTE KONSTANTES**

NAME/NAAM	SYMBOL/SIMBOOL	VALUE/WAARDE
Acceleration due to gravity <i>Swaartekragversnelling</i>	g	$9,8 \text{ m}\cdot\text{s}^{-2}$
Universal gravitational constant <i>Universele gravitasiekonstant</i>	G	$6,67 \times 10^{-11} \text{ N}\cdot\text{m}^2\cdot\text{kg}^{-2}$
Speed of light in a vacuum <i>Spoed van lig in 'n vakuum</i>	c	$3,0 \times 10^8 \text{ m}\cdot\text{s}^{-1}$
Planck's constant <i>Planck se konstante</i>	h	$6,63 \times 10^{-34} \text{ J}\cdot\text{s}$
Coulomb's constant <i>Coulomb se konstante</i>	k	$9,0 \times 10^9 \text{ N}\cdot\text{m}^2\cdot\text{C}^{-2}$
Charge on electron <i>Lading op elektron</i>	-e	$-1,6 \times 10^{-19} \text{ C}$
Electron mass <i>Elektronmassa</i>	$m_e$	$9,11 \times 10^{-31} \text{ kg}$
Mass of Earth <i>Massa van Aarde</i>	M	$5,98 \times 10^{24} \text{ kg}$
Radius of Earth <i>Radius van Aarde</i>	$R_E$	$6,38 \times 10^6 \text{ m}$

**TABLE 2: FORMULAE/TABEL 2: FORMULES****MOTION/BEWEGING**

$v_f = v_i + a \Delta t$	$\Delta x = v_i \Delta t + \frac{1}{2} a \Delta t^2$ or/of $\Delta y = v_i \Delta t + \frac{1}{2} a \Delta t^2$
$v_f^2 = v_i^2 + 2a\Delta x$ or/of $v_f^2 = v_i^2 + 2a\Delta y$	$\Delta x = \left( \frac{v_i + v_f}{2} \right) \Delta t$ or/of $\Delta y = \left( \frac{v_i + v_f}{2} \right) \Delta t$

**FORCE/KRAG**

$F_{\text{net}} = ma$	$p = mv$
$f_s^{\text{max}} = \mu_s N$	$f_k = \mu_k N$
$F_{\text{net}} \Delta t = \Delta p$ $\Delta p = mv_f - mv_i$	$w = mg$
$F = G \frac{m_1 m_2}{d^2}$ or/of $F = G \frac{m_1 m_2}{r^2}$	$g = G \frac{M}{d^2}$ or/of $g = G \frac{M}{r^2}$

**WORK, ENERGY AND POWER/ARBEID, ENERGIE EN DRYWING**

$W = F \Delta x \cos \theta$	$U = mgh$ or/of $E_p = mgh$
$K = \frac{1}{2} mv^2$ or/of $E_k = \frac{1}{2} mv^2$	$W_{\text{net}} = \Delta K$ or/of $W_{\text{net}} = \Delta E_k$ $\Delta K = K_f - K_i$ or/of $\Delta E_k = E_{kf} - E_{ki}$
$W_{\text{nc}} = \Delta K + \Delta U$ or/of $W_{\text{nc}} = \Delta E_k + \Delta E_p$	$P = \frac{W}{\Delta t}$
$P_{\text{av}} = F v_{\text{av}}$ / $P_{\text{gemid}} = F v_{\text{gemid}}$	

**WAVES, SOUND AND LIGHT/GOLWE, KLANK EN LIG**

$v = f \lambda$	$T = \frac{1}{f}$
$f_L = \frac{v \pm v_L}{v \pm v_s} f_s$ $f_L = \frac{v \pm v_L}{v \pm v_b} f_b$	$E = hf$ or/of $E = h \frac{c}{\lambda}$
$E = W_o + E_{k(\text{max})}$ or/of $E = W_o + K_{\text{max}}$ where/waar	
$E = hf$ and/en $W_o = hf_o$ and/en $E_{k(\text{max})} = \frac{1}{2} mv_{\text{max}}^2$ or/of $K_{\text{max}} = \frac{1}{2} mv_{\text{max}}^2$	

**ELECTROSTATICS/ELEKTROSTATIKA**

$F = \frac{kQ_1Q_2}{r^2}$	$E = \frac{kQ}{r^2}$
$V = \frac{W}{q}$	$E = \frac{F}{q}$
$n = \frac{Q}{e}$ or/of $n = \frac{Q}{q_e}$	

**ELECTRIC CIRCUITS/ELEKTRIESE STROOMBANE**

$R = \frac{V}{I}$	emf ( $\mathcal{E}$ ) = $I(R + r)$ emk ( $\mathcal{E}$ ) = $I(R + r)$
$R_s = R_1 + R_2 + \dots$ $\frac{1}{R_p} = \frac{1}{R_1} + \frac{1}{R_2} + \dots$	$q = I \Delta t$
$W = Vq$ $W = VI \Delta t$ $W = I^2 R \Delta t$ $W = \frac{V^2 \Delta t}{R}$	$P = \frac{W}{\Delta t}$ $P = VI$ $P = I^2 R$ $P = \frac{V^2}{R}$

**ALTERNATING CURRENT/WISSELSTROOM**

$I_{rms} = \frac{I_{max}}{\sqrt{2}}$ / $I_{wgk} = \frac{I_{maks}}{\sqrt{2}}$	$P_{ave} = V_{rms} I_{rms}$ / $P_{gemiddeld} = V_{wgk} I_{wgk}$
$V_{rms} = \frac{V_{max}}{\sqrt{2}}$ / $V_{wgk} = \frac{V_{maks}}{\sqrt{2}}$	$P_{ave} = I_{rms}^2 R$ / $P_{gemiddeld} = I_{wgk}^2 R$
	$P_{ave} = \frac{V_{rms}^2}{R}$ / $P_{gemiddeld} = \frac{V_{wgk}^2}{R}$