

NAAM/ NAME:



Western Cape
Government

Education

METROPOLE NORTH
EDUCATION DISTRICT
METROPOOL NOORD
ONDERWYS DISTRIK

**NATIONAL SENIOR CERTIFICATE
NASIONALE SENIOR SERTIFIKAAT**

GRADE 12/ GRAAD 12

**PHYSICAL SCIENCES: PHYSICS (P1)
FISIESE WETENSKAPPE: FISIKA (V1)**

SEPTEMBER 2016

MARKS/ Punte: 150

TIME/ Tyd: 3 hours/ 3 ure

**This question paper consists of 15 pages and 3 data sheets.
Hierdie vraestel bestaan uit 15 bladsye en 3 gegewensblaaie.**

INSTRUCTIONS AND INFORMATION

1. Write your name in the appropriate space on the ANSWER BOOK.
2. This question paper consists of ELEVEN questions. Answer ALL the questions in the ANSWER BOOK.
3. Start EACH question on a NEW page in the ANSWER BOOK.
4. Number the answers correctly according to the numbering system used in this question paper.
5. Leave ONE line between two sub questions, for example between QUESTION 2.1 and QUESTION 2.2.
6. You may use a non-programmable calculator.
7. You may use appropriate mathematical instruments.
8. YOU ARE ADVISED TO USE THE ATTACHED DATA SHEETS.
9. Show ALL formulae and substitutions in ALL calculations.
10. Round off your FINAL numerical answers to a minimum of TWO decimal places.
11. Give brief motivations, discussions, et cetera where required.
12. Write neatly and legibly.

QUESTION 1: MULTIPLE-CHOICE QUESTIONS

Four options are provided as possible answers to the following questions. Each question has only ONE correct answer. Choose the correct answer and write only the letter (A–D) next to the question number (1.1–1.10) in the ANSWER BOOK e.g. 1.11 E

- 1.1 If the total momentum of a system is changing:
- A particles of the system must be exerting forces on each other
 - B the system must be under the influence of gravity
 - C the system must move at constant velocity
 - D a net external force must be acting on the system (2)
- 1.2 An object is fired vertically upward. While it is moving upward:
- A its velocity and acceleration are both upward
 - B its velocity is upward and its acceleration is downward
 - C its velocity and acceleration are both downward
 - D its velocity is downward and its acceleration is upward (2)
- 1.3 Newton's first law of motion can be represented mathematically by:
- A $F_{\text{net}} = ma$
 - B $F_{\text{net}}\Delta t = m\Delta v$
 - C $F_{AB} = -F_{BA}$
 - D If $\sum F = 0$, then v is constant (2)
- 1.4 Two spherical objects attract each other with a gravitational force F . If the distance between the centres of the spheres is doubled, the force of attraction between them is:
- A $\frac{1}{4} F$
 - B $\frac{1}{2} F$
 - C F
 - D $2 F$ (2)

- 1.5 The work done on an object moving in a straight line on a ROUGH horizontal surface is equal to the change in the object's
- A momentum.
 - B gravitational potential energy.
 - C kinetic energy.
 - D acceleration. (2)
- 1.6 Sound waves are produced by the hooter of a truck that is approaching a stationary observer at a constant velocity. Compared to the sound waves detected by the driver of the truck, the sound waves detected by the observer have a greater
- A wavelength.
 - B frequency.
 - C period.
 - D speed. (2)
- 1.7 Which graph represents the relationship between the magnitude of the electrostatic force, F_E , between two charged spheres and the distance, r , between the centres of the spheres?

A

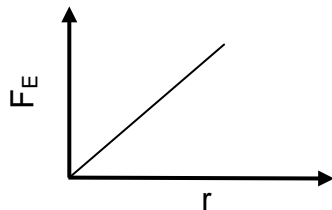

B

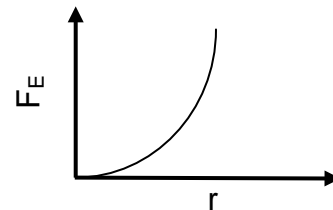

C

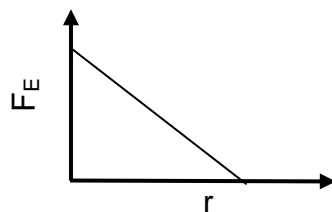

D

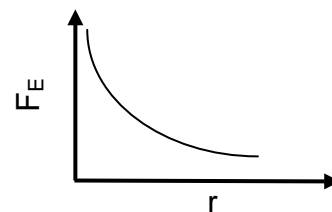

(2)

- 1.8 In the circuit shown below the resistances of the battery, ammeter, switch and connecting wires are negligible. The voltmeter has a very high resistance.

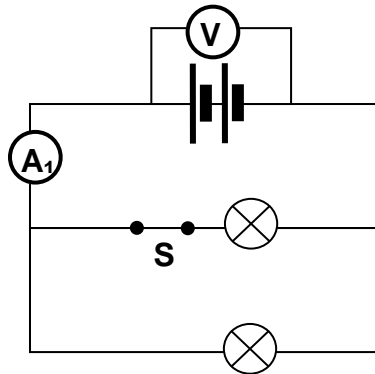

How are the readings on the ammeter and voltmeter affected if switch **S** is opened?

	AMMETER	VOLTMETER
A	Decrease	Increase
B	Decrease	No change
C	Increase	No change
D	Increase	Decrease

(2)

- 1.9 The diagram below shows possible transitions of electrons between energy levels of a particular element. Which transition would produce the line of SHORTEST WAVELENGTH on the emission spectrum of the element?

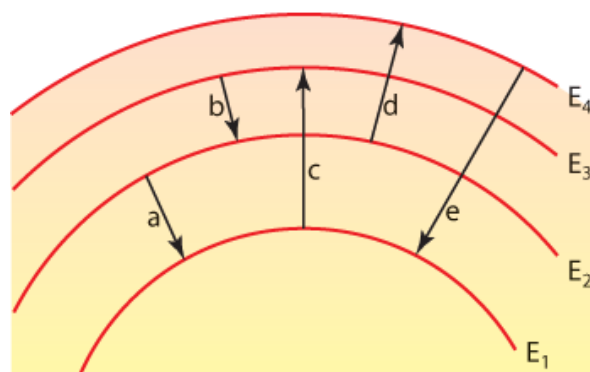

- A Transition a
B Transition c
C Transition d
D Transition e

(2)

- 1.10 The maximum kinetic energy of an electron ejected from the surface of a metal by a photon depends on:
- A The photon's frequency only
 - B The metal's work function only
 - C Both the photon's frequency and the metal's work function
 - D The photon's intensity and the metal's work function

(2)
[20]**QUESTION 2 (Start on a new page.)**

A block of mass 2 kg is connected with a light inextensible string that is hanging over a frictionless pulley, to another block of mass **X** kg. A force of 20 N is applied to the right at an angle of 20° to the horizontal on the 2 kg block while the block accelerates at $4 \text{ m}\cdot\text{s}^{-2}$ to the left.

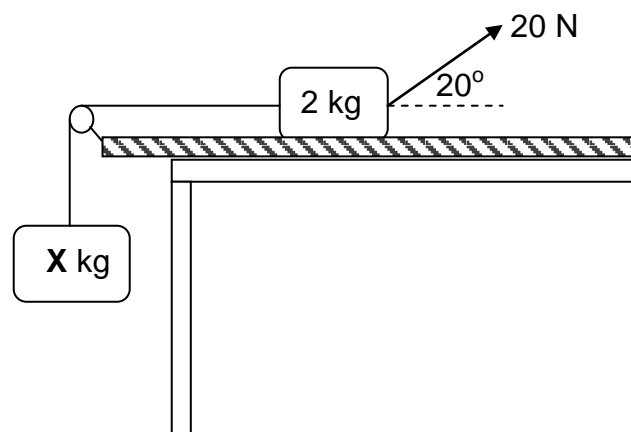

The coefficient of kinetic friction between the 2 kg block and the surface is 0,2. Ignore the effects of air friction.

- 2.1 State Newton's second law of motion in words (2)
- 2.2 Draw a labelled free-body diagram indicating ALL the forces acting on the **2 kg block**. (5)
- 2.3 Calculate **X**, the mass of the hanging block. (8)

[15]

QUESTION 3 (Start on a new page.)

A ball of mass 100 g is thrown vertically upwards from the ground with a velocity of $3,92 \text{ m}\cdot\text{s}^{-1}$.

The graph below illustrates how its velocity varies with time during the first few seconds of its motion. Ignore the effects of air resistance.

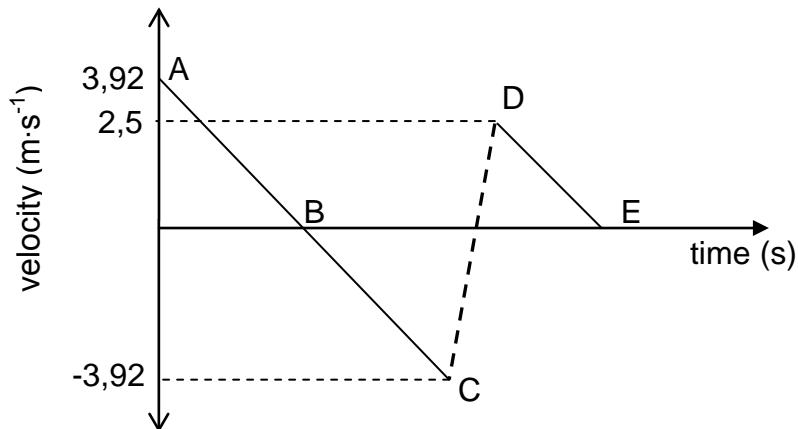

When the ball hits the ground for the first time, it is in contact with the ground for 0,1 s.

- 3.1 Define the term *projectile* (2)
- 3.2 Calculate the:
- 3.2.1 Maximum height the ball reaches above the ground (3)
- 3.2.2 Time taken by the ball to reach the ground (3)
- 3.3 Calculate the magnitude of the force the ball exerts on the ground while it is in contact with the ground (3)
- 3.4 Draw a position-time graph for the motion of the ball (A to E) with the ground as zero position.
- Clearly indicate the following on your graph:
- the times A, B,C,D and E. (3)
- [14]**

QUESTION 4 (Start on a new page.)

A man in a boat is stuck in the middle of a lake. In an attempt to reach the shore, 60 m away, the man throws an object of mass 1 kg horizontally at a speed of $10 \text{ m}\cdot\text{s}^{-1}$ in the direction shown in the diagram below.



The combined mass of the man and the boat is 100 kg. The effects of air resistance and friction between the water and the boat can be ignored.

- 4.1 Write down the *principle of conservation of linear momentum* in words, (2)
- 4.2 How will the force exerted on the object compare with the force exerted on the man-boat combination? Choose from GREATER THAN, SMALLER THAN or EQUAL TO. (1)
- 4.3 Give a reason for the answer to QUESTION 4.2 (3)
- 4.4 Calculate the time it will take to reach the shore after throwing the object. (6)
- [12]**

QUESTION 5 (Start on a new page.)

An object of mass 4 kg starting from rest slides down an inclined plane of length 3 m as shown in the diagram below. The plane is inclined by an angle of 30° to the ground. The coefficient of kinetic friction μ_k is 0,2..

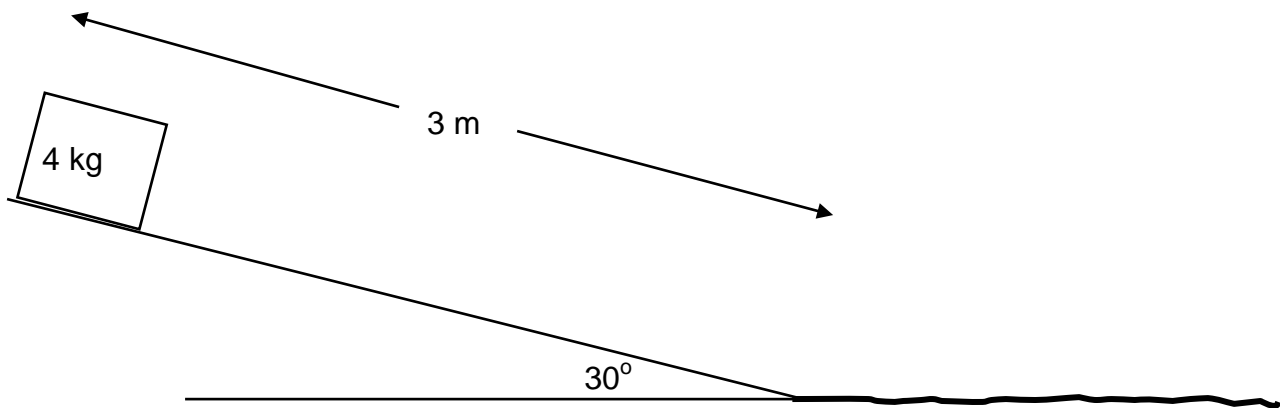

At the bottom of the plane, the mass slides along a rough horizontal surface with a coefficient of kinetic friction 0,5 until it comes to rest.

- 5.1 Draw a labelled free body diagram indicating ALL the forces acting on the object as it slides down the incline (3)
- 5.2 Write down the work-energy theorem in words (2)
- Calculate the:
- 5.3 Distance the object slides along the rough horizontal surface. (8)
- [13]**

QUESTION 6 (Start on a new page.)

A traffic officer is standing on the side of a road where the speed limit is $100 \text{ km}\cdot\text{h}^{-1}$. He hears the hooter of a car that is travelling at constant velocity on this road. The hooter emits sound waves of frequency $433,64 \text{ Hz}$.

The wavelength of the sound waves detected by the traffic officer is $0,72 \text{ m}$. The speed of sound in air is $340 \text{ m}\cdot\text{s}^{-1}$.

- 6.1 Calculate the frequency of the detected sound wave. (3)
- 6.2 State the Doppler-effect in words. (2)
- 6.3 Is the car travelling towards or away from the traffic officer? Give a reason for the answer (2)
- 6.4 Is the car exceeding the speed limit? Support your answer by means of a calculation. (6)
- 6.5 How will the frequency of the sound waves detected by the traffic officer be affected if the car travels at a lower constant velocity? Choose from GREATER THAN, LESS THAN or THE SAME AS. (1)
- [14]**

QUESTION 7 (Start on a new page.)

Three charged particles Q_1 , Q_2 and Q_3 carrying charges of $+2 \times 10^{-5} \text{ C}$, $-2 \times 10^{-4} \text{ C}$ and $+2 \times 10^{-4} \text{ C}$ respectively are positioned as shown in the diagram below.

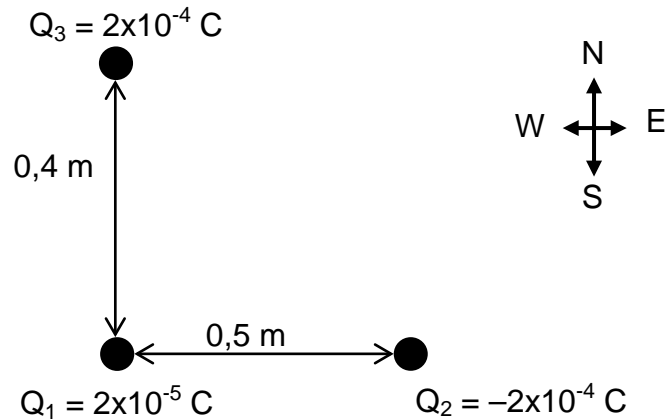

- 7.1 State *Coulomb's Law* in words (2)
- 7.2 Calculate the number of excess electrons on charge Q_2 . (3)
- 7.3 Calculate the net electrostatic force exerted on charge Q_1 by the charges Q_2 and Q_3 . (6)
- [11]**

QUESTION 8 (Start on a new page.)

Two charged particles Q_1 and Q_2 are placed 30 cm apart as shown in the diagram below. Point P is 10 cm east of charge Q_2 .

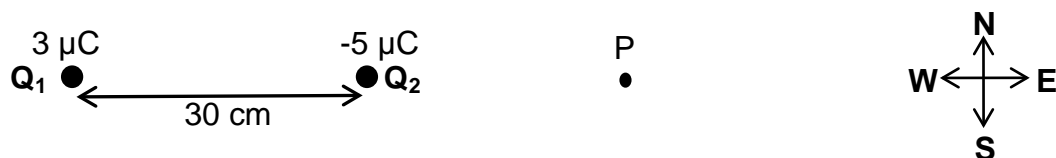

- 8.1 Define the electric field at point in words (2)
- 8.2 Calculate the magnitude and direction of the net electric field at point P (6)
- [8]**

QUESTION 9 (Start on a new page.)

- 9.1 The circuit below is setup to determine the emf (ϵ) and internal resistance (r) of a fresh battery.

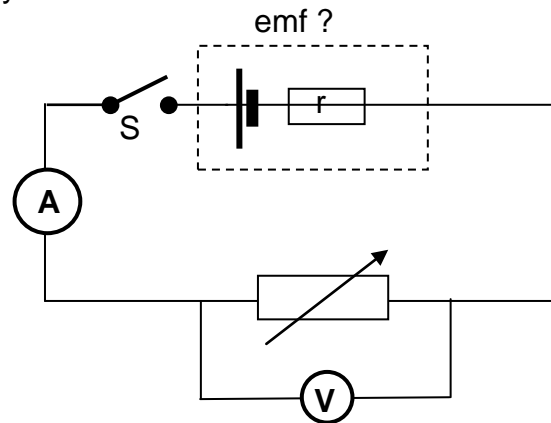

The data obtained from the investigation is plotted and the following graph is obtained.

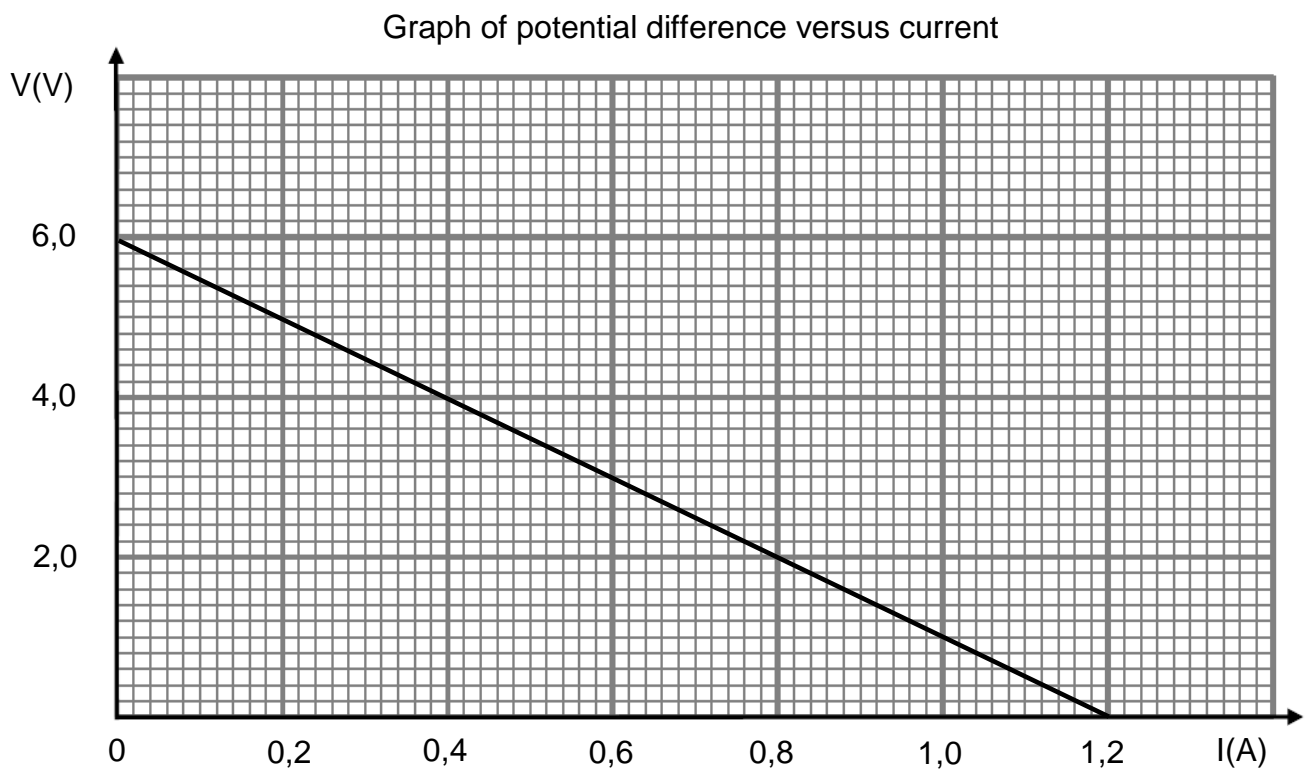

- 9.1.1 Write down the value of the emf of the battery (1)
- 9.1.2 Calculate V_{internal} if the current in the circuit is 0,4 A (3)

- 9.2 A battery with an internal resistance of $0,5 \Omega$ and an emf (ϵ) of 24 V is connected in a circuit, as shown below. With switch **S** closed, the high-resistance voltmeter (**V**) has a reading of $22,26 \text{ V}$

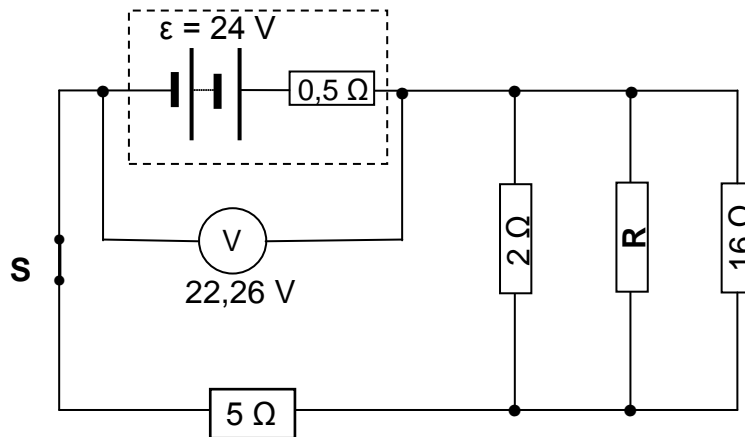

- 9.2.1. Define the term *emf of 24 V* in terms of work done. (2)
- 9.2.2 Calculate the power dissipated in the 16Ω resistor (7)
- 9.2.3 Calculate the current passing through resistor **R** (4)

Resistor **R** is removed from the circuit

- 9.2.4 Will the power dissipated in the 16Ω resistor INCREASE, DECREASE or REMAIN CONSTANT? Explain the answer without doing any calculations. (4)

[21]

QUESTION 10 (Start on a new page.)

A simplified diagram of an AC generator is shown below. The direction of the current in the coil is from **C** to **D**.

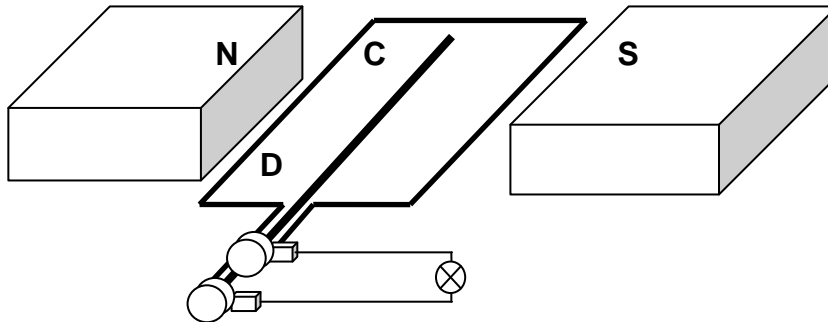

- 10.1 In which direction is the coil being rotated? Choose from **CLOCKWISE** or **ANTICLOCKWISE** (1)

The output potential difference (V_{max}) of the generator shown in the above diagram is 311,13 V at 50 Hz.

- 10.2 Starting from the position shown in the diagram above, sketch a graph of output voltage versus time for one complete cycle of the coil. (2)

- 10.3 An electrical device connected to the generator shown above, consumes $9,45 \times 10^6$ J of energy in two hours. Calculate the:

10.3.1. Power rating of the electrical device. (3)

10.3.2 Maximum current through the electrical device when connected to the generator shown above (5)

[11]

QUESTION 11 (Start on a new page.)

During an investigation, light of different frequencies is shone onto the metal cathode of a photocell. The maximum kinetic energy of the emitted photoelectrons is measured. The graph below shows the results obtained.

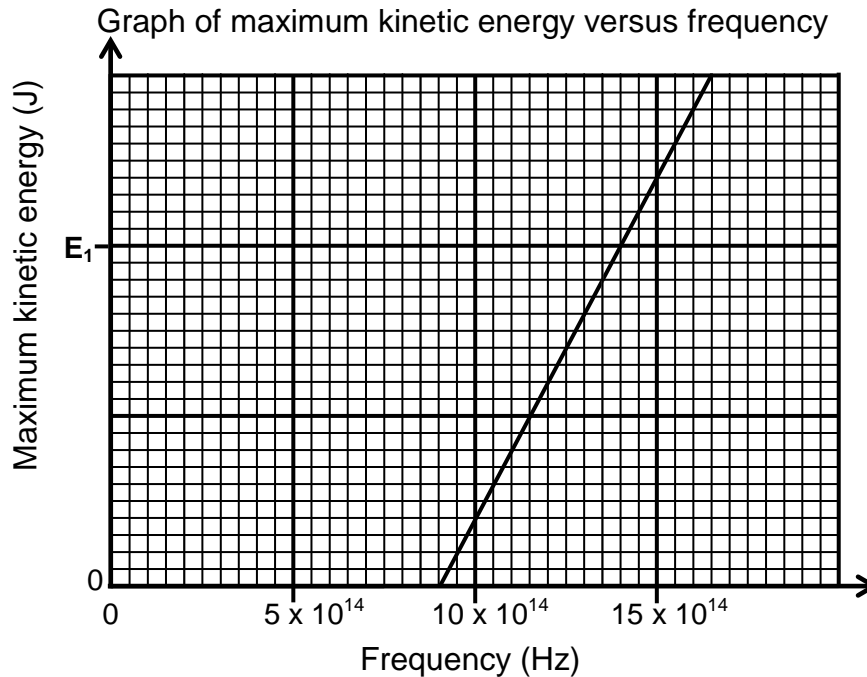

- 11.1 Define the term *work function* in words. (2)
- 11.2 Calculate the work function of the metal. (3)
- 11.3 Calculate the magnitude of maximum kinetic frequency E_1 indicated on the graph. (4)
- The intensity of the incident light of frequency 15×10^{14} Hz is now increased.
- 11.4 How will the maximum velocity of the ejected photoelectron be affected?
Choose from INCREASE, DECREASE or REMAIN THE SAME. Give a reason for the answer. (2)

[11]**TOTAL 150**

**DATA FOR PHYSICAL SCIENCES GRADE 12
PAPER 1 (PHYSICS)**

**GEGEWENS VIR FISIESTE WETENSAPPE GRAAD 12
VRAESTEL 1 (FISIKA)**

TABLE 1: PHYSICAL CONSTANTS/TABEL 1: FISIESTE KONSTANTES

NAME/NAAM	SYMBOL/SIMBOOL	VALUE/WAARDE
Acceleration due to gravity <i>Swaartekragversnelling</i>	g	9,8 m·s ⁻²
Universal gravitational constant <i>Universele gravitasiekonstant</i>	G	6,67 x 10 ⁻¹¹ N·m ² ·kg ⁻²
Speed of light in a vacuum <i>Spoed van lig in 'n vakuum</i>	c	3,0 x 10 ⁸ m·s ⁻¹
Planck's constant <i>Planck se konstante</i>	h	6,63 x 10 ⁻³⁴ J·s
Coulomb's constant <i>Coulomb se konstante</i>	k	9,0 x 10 ⁹ N·m ² ·C ⁻²
Charge on electron <i>Lading op elektron</i>	-e	-1,6 x 10 ⁻¹⁹ C
Electron mass <i>Elektronmassa</i>	m _e	9,11 x 10 ⁻³¹ kg
Mass of Earth <i>Massa van Aarde</i>	M	5,98 x 10 ²⁴ kg
Radius of Earth <i>Radius van Aarde</i>	R _E	6,38 x 10 ⁶ m

TABLE 2: FORMULAE/TABEL 2: FORMULES

MOTION/BEWEGING

$v_f = v_i + a \Delta t$	$\Delta x = v_i \Delta t + \frac{1}{2} a \Delta t^2$ or/of $\Delta y = v_i \Delta t + \frac{1}{2} a \Delta t^2$
$v_f^2 = v_i^2 + 2a\Delta x$ or/of $v_f^2 = v_i^2 + 2a\Delta y$	$\Delta x = \left(\frac{v_i + v_f}{2} \right) \Delta t$ or/of $\Delta y = \left(\frac{v_i + v_f}{2} \right) \Delta t$

FORCE / KRAG

$F_{\text{net}} = ma$	$p = mv$
$f_s^{\text{max}} = \mu_s N$	$f_k = \mu_k N$
$F_{\text{net}} \Delta t = \Delta p$ $\Delta p = mv_f - mv_i$	$w = mg$
$F = G \frac{m_1 m_2}{d^2}$ or/of $F = G \frac{m_1 m_2}{r^2}$	$g = G \frac{M}{d^2}$ or/of $g = G \frac{M}{r^2}$

WORK, ENERGY AND POWER/ARBEID, ENERGIE EN DRYWING

$W = F\Delta x \cos \theta$	$U = mgh$ or/of $E_p = mgh$
$K = \frac{1}{2}mv^2$ or/of $E_k = \frac{1}{2}mv^2$	$W_{\text{net}} = \Delta K$ or/of $W_{\text{net}} = \Delta E_k$ $\Delta K = K_f - K_i$ or/of $\Delta E_k = E_{kf} - E_{ki}$
$W_{\text{nc}} = \Delta K + \Delta U$ or/of $W_{\text{nc}} = \Delta E_k + \Delta E_p$	$P = \frac{W}{\Delta t}$
$P_{\text{ave}} = Fv_{\text{ave}}$ / $P_{\text{gemid}} = Fv_{\text{gemid}}$	

WAVES, SOUND AND LIGHT/GOLWE, KLANK EN LIG

$v = f\lambda$	$T = \frac{1}{f}$
$f_L = \frac{v \pm v_L}{v \pm v_s} f_s$ $f_L = \frac{v \pm v_L}{v \pm v_b} f_b$	$E = hf$ or /of $E = h\frac{c}{\lambda}$
$E = W_o + E_{k(\text{max})}$ or/of $E = W_o + K_{\text{max}}$ where/waar	
$E = hf$ and/en $W_o = hf_o$ and/en $E_{k(\text{max})} = \frac{1}{2}mv_{\text{max}}^2$ or/of $K_{\text{max}} = \frac{1}{2}mv_{\text{max}}^2$	

ELECTROSTATICS / ELEKTROSTATIKA

$F = \frac{kQ_1Q_2}{r^2}$	$E = \frac{kQ}{r^2}$
$V = \frac{W}{q}$	$E = \frac{F}{q}$
$n = \frac{Q}{e}$ or/of $n = \frac{Q}{q_e}$	

CURRENT ELECTRICITY / STROOMELEKTRISITEIT

$R = \frac{V}{I}$	emf (\mathcal{E}) = $I(R + r)$ emk (\mathcal{E}) = $I(R + r)$
$R_s = R_1 + R_2 + \dots$ $\frac{1}{R_p} = \frac{1}{R_1} + \frac{1}{R_2} + \dots$	$q = I \Delta t$
$W = Vq$ $W = VI \Delta t$ $W = I^2 R \Delta t$ $W = \frac{V^2 \Delta t}{R}$	$P = \frac{W}{\Delta t}$ $P = VI$ $P = I^2 R$ $P = \frac{V^2}{R}$

ALTERNATING CURRENT / WISSELSTROOM

$I_{\text{rms}} = \frac{I_{\text{max}}}{\sqrt{2}}$ / $I_{\text{wgk}} = \frac{I_{\text{maks}}}{\sqrt{2}}$	$P_{\text{ave}} = V_{\text{rms}} I_{\text{rms}}$ / $P_{\text{gemiddeld}} = V_{\text{wgk}} I_{\text{wgk}}$
$V_{\text{rms}} = \frac{V_{\text{max}}}{\sqrt{2}}$ / $V_{\text{wgk}} = \frac{V_{\text{maks}}}{\sqrt{2}}$	$P_{\text{ave}} = I_{\text{rms}}^2 R$ / $P_{\text{gemiddeld}} = I_{\text{wgk}}^2 R$
	$P_{\text{ave}} = \frac{V_{\text{rms}}^2}{R}$ / $P_{\text{gemiddeld}} = \frac{V_{\text{wgk}}^2}{R}$