



**education**

Department:  
Education  
PROVINCE OF KWAZULU-NATAL

**PHYSICAL SCIENCES: (PHYSICS) P1**

**PREPARATORY EXAMINATION**

**SEPTEMBER 2017**

**NATIONAL  
SENIOR CERTIFICATE**

**GRADE 12**

**MARKS: 150**

**TIME : 3 hours**

**This question paper consists of 15 pages and a 3-page data sheet.**

**INSTRUCTIONS AND INFORMATION TO CANDIDATES**

1. Write your name on the **ANSWER BOOK**.
2. This question paper consists of TEN questions. Answer ALL the questions in the ANSWER BOOK.
3. Start EACH question on a NEW page in the ANSWER BOOK.
4. Number the answers correctly according to the numbering system used in this question paper.
5. Leave ONE line between two sub-sections, for example between QUESTION 2.1 and QUESTION 2.2.
6. You may use a non-programmable calculator.
7. You may use appropriate mathematical instruments.
8. You are advised to use the attached DATA SHEET.
9. Show ALL formulae and substitutions in ALL calculations.
10. Round off your final numerical answers to a minimum of TWO decimal places.
11. Give brief motivations, discussions, et cetera where required.
12. Write neatly and legibly.

**QUESTION 1: MULTIPLE- CHOICE QUESTIONS**

Four possible options are provided as answers to the following questions. Each question has only ONE correct answer. Choose the best answer and write down **A**, **B**, **C** or **D** next to the question number (1.1–1.10) on your ANSWER BOOK.

1.1 A car is driven along a horizontal road at constant velocity. Which one of the following statements is true?

- A** The forces acting on the car are not in equilibrium.
- B** There are no forces acting on the car.
- C** The resultant force acting on the car is zero.
- D** There is no frictional force acting on the car. (2)

1.2 An airbag can protect a driver from serious injury during a collision. Which ONE of the following best explains why this is possible?

	TIME OF IMPACT	NET FORCE
<b>A</b>	Increases	Increases
<b>B</b>	Decreases	Decreases
<b>C</b>	Increases	Decreases
<b>D</b>	Remain the same	Decreases

(2)

1.3 An object is projected vertically upwards from the roof of a building and it hits the ground some time later. The effects of air resistance are negligible. Up is taken as the positive direction.

The acceleration-time graph which best represents the vertical motion of the object from the time it was projected up until it hit the ground is:

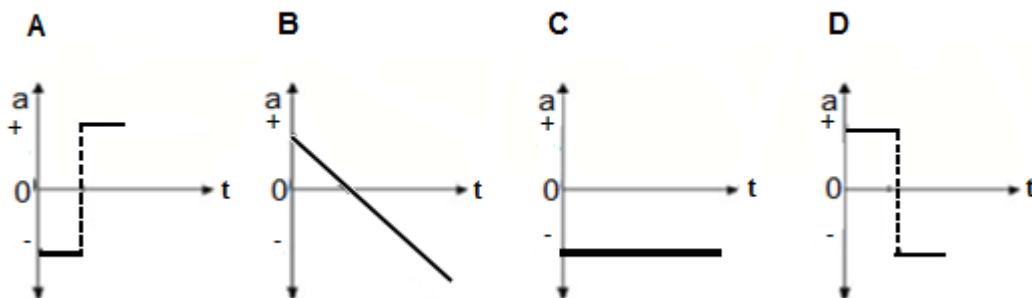

(2)

- 1.4 A vehicle with mass  $m$  is moving horizontally at a constant velocity on a frictionless path. The kinetic energy of the vehicle is  $K$  and the momentum is  $p$ . The velocity of the vehicle can be given as:

- A  $\frac{K}{p}$   
 B  $\frac{2K}{p}$   
 C  $\frac{K}{p}$   
 D  $\frac{p}{K}$

(2)

- 1.5 A car sounds its horn whilst travelling at constant velocity along a straight road. At time  $t = 0$  the car is at position **X** as shown below. At time  $t = t_1$  the car moves past a stationary listener **L**. At time  $t = t_2$  the car is at position **Y**.



Which ONE of the following graphs best represents the variation of the frequency (pitch) of the horn with time as heard by the listener?

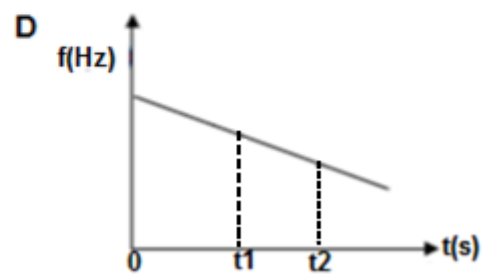
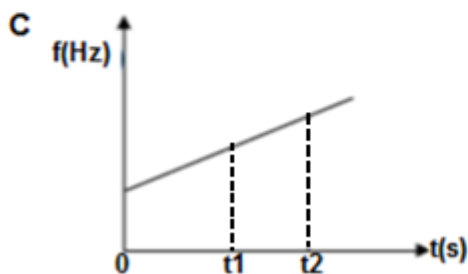
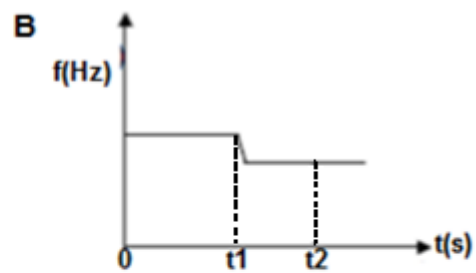
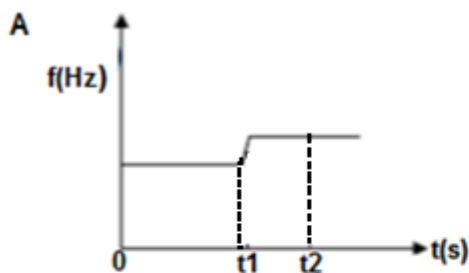

(2)

- 1.6 Which graph represents the relationship between the magnitude of the electrostatic force,  $F_E$ , between two charged spheres and the distance,  $r$ , between the centres of the spheres?

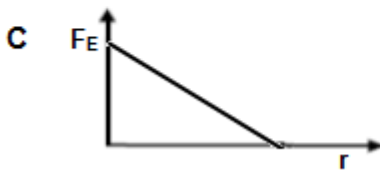
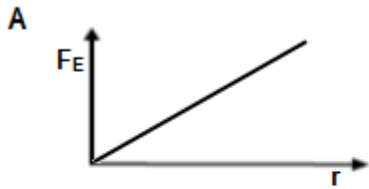

(2)

- 1.7 The figure below shows a 12 V, 21 W lamp. The circuit is protected by a fuse which melts if the current in the circuit exceeds 2 A.

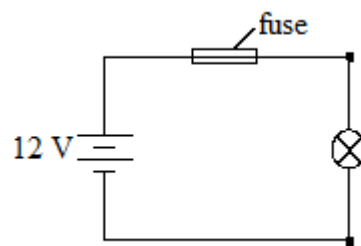

The current passing through the lamp without melting the fuse is:

**A** 0,57 A

**B** 1,75 A

**C** 10,5 A

**D** 6 A

(2)

- 1.8 A lamp connected to an AC supply lights up with the same brightness as it does when connected to an  $X$  volt DC source. The power dissipated by the lamp, is equal to ...

**A**  $\frac{1}{2}(X)(I_{\max})$ .

**B**  $(X)(I_{\max})$ .

**C**  $(X)\frac{I_{\max}}{\sqrt{2}}$

**D**  $(X)(I_{\max})$ .

(2)

- 1.9 The light from an argon discharge tube is analysed. The following line emission spectrum shows two of the spectral lines observed.



The spectrum of light from a distant star appears to have been *red shifted*.

How will the lines appear to shift compared to the above diagram?

- A P and Q will both shift left
- B P and Q will both shift right
- C P will shift right and Q will shift left
- D P will shift left and Q will shift right (2)
- 1.10 The graph below shows the relationship between the kinetic energy of the ejected photo-electrons and the frequency of the incident radiation.

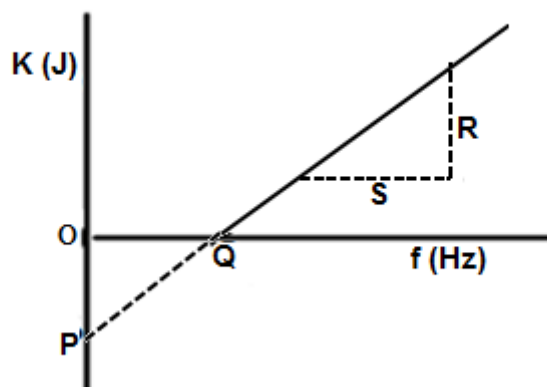

Which set correctly shows the information provided by P, Q, R and S?

	$\frac{R}{S}$	P	Q
A	Planck's constant, $h$	Threshold frequency, $f_0$	Work function, $W_0$
B	Work function, $W_0$	$E_K$ of electrons when $f = 0$	Threshold frequency, $f_0$
C	Threshold frequency, $f_0$	Work function, $W_0$	Planck's constant, $h$
D	Planck's constant, $h$	Negative of work function, $-W_0$	Threshold frequency, $f_0$

(2)  
[20]

**QUESTION 2 (Start on a new page)**

- 2.1 Two blocks of different masses are attached to each other via a light inextensible string which is placed over a massless and frictionless pulley. A block of mass 2 kg is placed on a smooth surface and attached to the wall by a second string which makes an angle of  $70^\circ$  to the vertical as shown in the diagram below. A second block of mass 5 kg is left to hang freely. The entire system is in equilibrium and all forms of friction can be ignored.

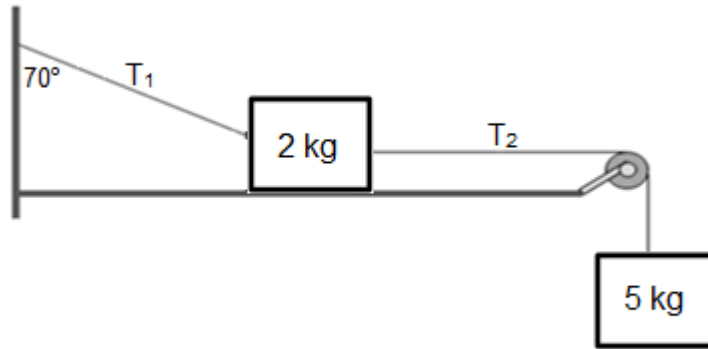

- 2.1.1 State Newton's Second Law of Motion in words. (2)
- 2.1.2 Draw a labelled free body diagram for the 2 kg mass. (4)
- 2.1.3 Determine the magnitude of the tension force  $T_2$ . (2)
- 2.1.4 Calculate the magnitude of the normal force exerted on the 2 kg mass. (4)
- 2.2 An astronaut has a mass of 94 kg on Earth. He goes on a space mission to the moon. On the moon he finds that he has a weight of 152,28 N. The mass of the moon is  $7,348 \times 10^{22}$  kg. Calculate the gravitational acceleration on the moon. (3)

**[15]**

**QUESTION 3 (Start on a new page)**

Ball **A** is thrown vertically upwards from the top of a balcony overlooking the street. It leaves the thrower's hand at a velocity of  $5 \text{ m}\cdot\text{s}^{-1}$  and it hits the street below the balcony. At the same instant that ball **A** is thrown, ball **B** is thrown upwards from the street. Ball **B** leaves the thrower's hand at a velocity of  $8 \text{ m}\cdot\text{s}^{-1}$ .

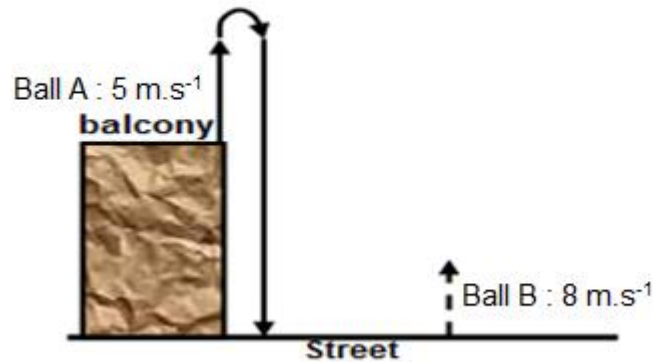

- 3.1 What is meant by a *projectile*? (2)
- 3.2 Calculate the time taken by ball **A** to reach its maximum height. (3)
- 3.3 Calculate the velocity of ball **B** at the moment ball **A** is at its maximum height. (3)
- 3.4 After how many seconds will the magnitudes of the velocities of the two balls be equal? (5)
- 3.5 Use your answer in QUESTION 3.4 to determine the height of ball **A** from its starting point. (3)

**[16]**



**QUESTION 4 (Start on a new page)**

During a visit to an amusement park, Asisipho and Ziphokazi ride the bumper cars. Asisipho in her car moves to the left across the smooth surface at  $2.4 \text{ m}\cdot\text{s}^{-1}$  and collides with Ziphokazi's car which is at rest. The collision is **elastic**. After the collision Asisipho continues to move in the same direction with a velocity of  $0.8 \text{ m}\cdot\text{s}^{-1}$ . The combined mass of Asisipho and her car is  $340 \text{ kg}$ .

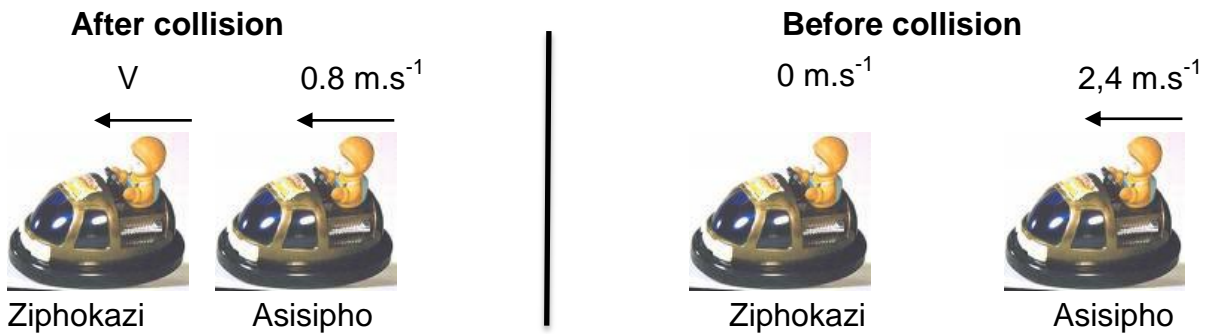

4.1 Name and state the Principle illustrated above.

(3)

4.2 Calculate the combined mass of Ziphokazi and her car.

(8)

[11]

**QUESTION 5 (Start on a new page)**

A skier, mass 70 kg, is ready to ski. He started from rest at point **A** (top of slope) and skied down a slope inclined at  $30^\circ$  to the horizontal. He skied straight from point **A** to point **B** over a distance of 120 m without his ski poles touching the snow as shown in the diagram below, which is not drawn to scale.

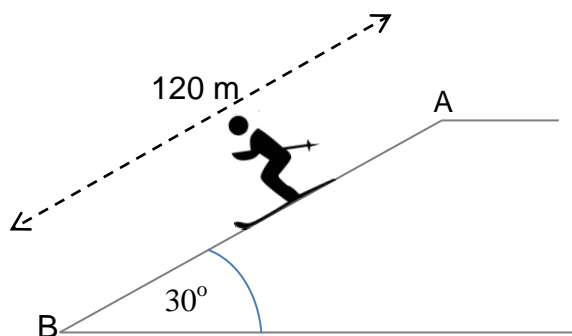

The total kinetic friction between the skis and the slope was 150 N between points **A** and **B**.

- 5.1 Draw a free-body diagram showing all the forces acting on the skier while he was moving down the slope. (3)
- 5.2 Calculate the net work done on the skier as he moved from point **A** to point **B**. (5)
- 5.3 State the WORK-ENERGY THEOREM in words. (2)
- 5.4 Hence, determine the magnitude of the velocity of the skier at the bottom of the slope. (4)

**[14]**

**QUESTION 6 (Start on a new page)**

A man standing on the sidewalk notices that the sound of a racing car changes when the car moves towards him at a constant speed of  $200 \text{ km}\cdot\text{h}^{-1}$  compared to when the car is moving away from him.



Assume that the speed of sound in air is  $340 \text{ m}\cdot\text{s}^{-1}$ .

- 6.1 Name and state the phenomenon illustrated above. (3)
- 6.2 Convert  $200 \text{ km}\cdot\text{h}^{-1}$  to  $\text{m}\cdot\text{s}^{-1}$ . (2)
- 6.3 If the frequency of sound that the man will hear when the car is approaching him is  $298,84 \text{ Hz}$ , calculate the frequency of sound produced by the car. (5)
- 6.4 State TWO uses of the Doppler flow meter in medical field. (2)
- [12]**

**QUESTION 7 (Start on a new page)**

Two small identical, charged spheres which carry charges of  $+3 \text{ nC}$  and  $+5 \text{ nC}$  are placed a distance of  $40 \text{ mm}$  apart as shown in the diagram.

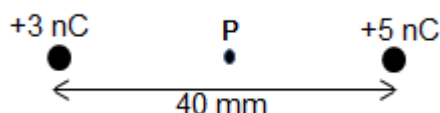

- 7.1 Define electric field strength. (2)
- 7.2 Draw the electric field pattern for these two charged spheres. (3)
- 7.3 Along the line joining the two small spheres, there is a point **P**, which is  $10 \text{ mm}$  from the  $+3 \text{ nC}$  charge. Calculate the magnitude of the resultant electric field strength at **P**. (6)
- 7.4 An electron is placed at point **P**. Calculate the force experienced by the electron due to the electric field. (4)
- [15]**

**QUESTION 8 (Start on a new page)**

- 8.1 In the circuit represented below, the battery has an *emf* of 12 V and an internal resistance,  $r$ . The battery is connected to an ammeter of negligible resistance and three resistors 3,5  $\Omega$ , 2  $\Omega$  and 6  $\Omega$ . There is a voltmeter of high resistance connected across 3,5  $\Omega$ . When the switch is closed, the ammeter has a reading of 2,2 A and  $V_1$  has a reading of 11 V.

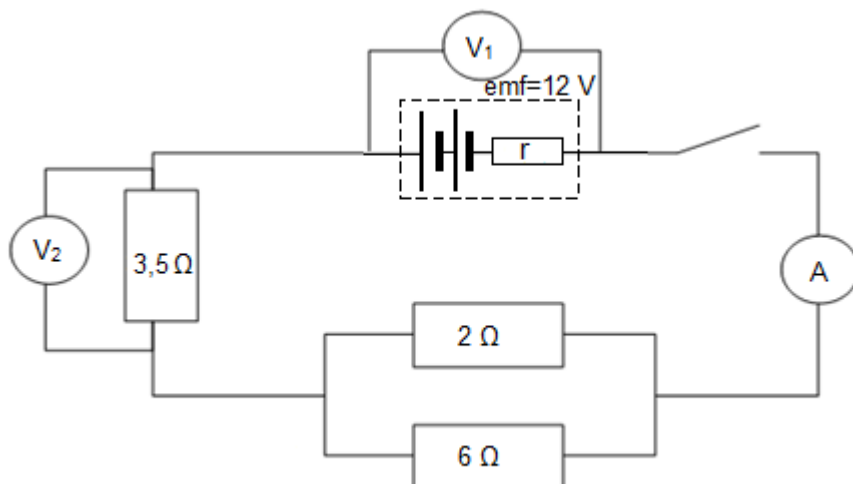

- 8.1.1 State Ohm's Law in words. (2)
- 8.1.2 Calculate the total resistance of the external circuit. (3)
- 8.1.3 Calculate the internal resistance,  $r$ , of the battery. (4)
- 8.1.4 Calculate the reading on  $V_2$ . (3)
- 8.1.5 Calculate how many joules of energy the battery supplies to the 3,5  $\Omega$  in 5 minutes. (4)
- 8.2 The switch is replaced with a high-resistance nichrome wire (i.e. switch is replaced with a resistor).
- How will the temperature of the battery be affected?  
State only INCREASES, DECREASES or REMAIN THE SAME. (1)
- 8.3 An electronic appliance is marked 240 V, 2000 W. Electricity costs R1.25 per kWh. Calculate how much it costs to operate this appliance for 2 hours. (3)

**[20]**

**QUESTION 9 (Start on a new page)**

The diagram below shows the output of a generator installed on a farm.

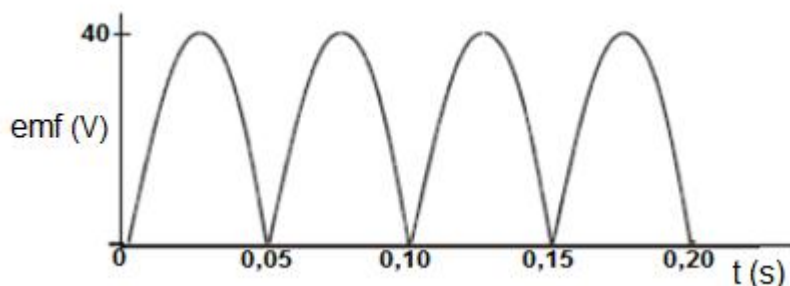

- 9.1 Does this graph represent the output of an AC or a DC generator? Explain. (2)
- 9.2 Name the principle under which generators operate. (1)
- 9.3 State the energy conversion that takes place in generators. (1)
- 9.4 What structural change could be made on a DC generator in order to convert it to an AC generator? (2)
- 9.5 Which one of the following diagrams (**A** or **B**) correctly illustrates the position of the coil at a time of 0,05s? (1)



- 9.6 State two reasons why a generator will be less than 100% efficient, i.e. state two ways that energy is converted into forms other than electrical energy by a generator. (2)
- 9.7 List 2 ways of increasing the output of the generator without affecting the frequency of the induced emf. (2)

Generators need a source of mechanical energy to turn the coil inside a magnetic field. The picture below shows an example of a wind generator.



When the wind blows at maximum speed, the generator delivers  $1.035 \times 10^6 \text{ W}$  in a resistor of  $490 \ \Omega$ .

9.8 Calculate the root-mean square (rms) current produced by this generator. (3)  
**[14]**

**QUESTION 10 (Start on a new page)**

The photocell shown below consists of a metal plate **P** and a smaller electrode **E** placed inside an evacuated glass tube, called a photocell.

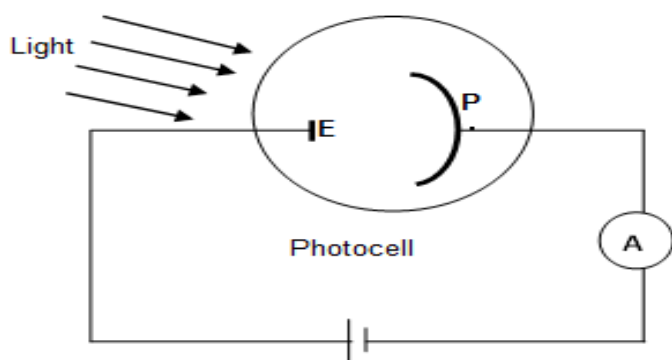

When the photocell is in the dark the ammeter reads zero. But when monochromatic red light with a frequency of  $4.65 \times 10^{14}$  Hz from a 50 W bulb is shone on the photocell, a small current is registered on the ammeter.

The Table below shows the work function of two metals, caesium and gold.

Metal	Caesium	Gold
Work function, $W_0$ (J)	$3,00 \times 10^{-19}$	$7,81 \times 10^{-19}$

- 10.1 Determine by calculation which metal, caesium or gold, should be chosen to make **P** to ensure that the photocell works with red light? Explain your choice clearly. (5)

The 50 W bulb is replaced with another bulb with higher intensity.

- 10.2 What effect will this have on the ammeter reading? Give a reason for your answer. (2)

- 10.3 Light of frequency  $1.21 \times 10^{15}$  Hz now falls onto **P**, and **P** is made of caesium.

- 10.3.1 Calculate the speed of an electron that is emitted. (5)

- 10.3.2 Does the work function of caesium INCREASE, DECREASE or REMAIN THE SAME when different frequencies of light are used? (1)

**[13]**

**GRAND TOTAL: 150**

**DATA FOR PHYSICAL SCIENCES GRADE 12  
PAPER 1 (PHYSICS)**

**GEGEWENS VIR FISIESTE WETENSAPPE GRAAD 12  
VRAESTEL 1 (FISIKA)**

**TABLE 1: PHYSICAL CONSTANTS / TABEL 1: FISIESTE KONSTANTES**

NAME / NAAM	SYMBOL / SIMBOOL	VALUE / WAARDE
Acceleration due to gravity <i>Swaartekragversnelling</i>	G	$9,8 \text{ m}\cdot\text{s}^{-2}$
Universal gravitational constant <i>Universele gravitasiekonstante</i>	G	$6,67 \times 10^{-11} \text{ N}\cdot\text{m}^2\cdot\text{kg}^{-2}$
Speed of light in a vacuum <i>Spoeo van lig in 'n vacuum</i>	C	$3,0 \times 10^8 \text{ m}\cdot\text{s}^{-1}$
Planck's constant <i>Planck se konstante</i>	H	$6,63 \times 10^{-34} \text{ J}\cdot\text{s}$
Coulomb's constant <i>Coulomb se konstante</i>	K	$9,0 \times 10^9 \text{ N}\cdot\text{m}^2\cdot\text{C}^{-2}$
Charge on electron <i>Lading op electron</i>	$e^-$	$-1,6 \times 10^{-19} \text{ C}$
Electron mass <i>Elektronmassa</i>	$m_e$	$9,11 \times 10^{-31} \text{ kg}$
Mass of Earth <i>Massa van Aarde</i>	M	$5,98 \times 10^{24} \text{ kg}$
Radius of Earth <i>Radius van Aarde</i>	$R_E$	$6,38 \times 10^6 \text{ m}$



TABLE 2: FORMULAE / TABEL 2: FORMULES

**MOTION / BEWEGING**

$v_f = v_i + a \Delta t$	$\Delta x = v_i \Delta t + \frac{1}{2} a \Delta t^2$ or/of $\Delta y = v_i \Delta t + \frac{1}{2} a \Delta t^2$
$v_f^2 = v_i^2 + 2a\Delta x$ or/of $v_f^2 = v_i^2 + 2a\Delta y$	$\Delta x = \left( \frac{v_i + v_f}{2} \right) \Delta t$ or/of $\Delta y = \left( \frac{v_i + v_f}{2} \right) \Delta t$

**FORCE / KRAG**

$F_{\text{net}} = ma$	$p = mv$
$f_{s(\text{max})} = \mu_s N$	$f_k = \mu_k N$
$F_{\text{net}} \Delta t = \Delta p$ $\Delta p = mv_f - mv_i$	$w = mg$
$F = \frac{Gm_1 m_2}{r^2}$	$g = \frac{Gm}{r^2}$

**WORK, ENERGY AND POWER / ARBEID, ENERGIE EN DRYWING**

$W = F \Delta x \cos \theta$	$U = mgh$ or/of $E_p = mgh$
$K = \frac{1}{2} mv^2$ or/of $E_k = \frac{1}{2} mv^2$	$W_{\text{net}} = \Delta K$ or/of $W_{\text{net}} = \Delta E_k$ $\Delta K = K_f - K_i$ or/of $\Delta E_k = E_{kf} - E_{ki}$
$W_{\text{nc}} = \Delta K + \Delta U$ or/of $W_{\text{nc}} = \Delta E_k + \Delta E_p$	$P = \frac{W}{\Delta t}$
$P_{\text{av}} = F \cdot v_{\text{av}} / P_{\text{gem}} = F \cdot v_{\text{gem}}$	

**WAVES, SOUND AND LIGHT / GOLWE, KLANK EN LIG**

$v = f \lambda$	$T = \frac{1}{f}$
$f_L = \frac{v \pm v_L}{v \pm v_s} f_s$	$E = hf$ or/of $E = h \frac{c}{\lambda}$
$E = W_o + E_{k(\text{max})}$ or/of $E = W_o + K_{(\text{max})}$ where/waar $E = hf$ and/en $W_o = hf_o$ and/en $E_{k(\text{max})} = \frac{1}{2} mv_{\text{max}}^2$ or/of $K_{(\text{max})} = \frac{1}{2} mv_{\text{max}}^2$	

**ELECTROSTATICS / ELEKTROSTATIKA**

$F = \frac{kQ_1Q_2}{r^2}$	$E = \frac{kQ}{r^2}$
$V = \frac{W}{q}$	$E = \frac{F}{q}$
$n = \frac{Q}{e}$ OR/OF $n = \frac{Q}{q_e}$	

**ELECTRIC CIRCUITS / ELEKTRIESE STROOMBANE**

$R = \frac{V}{I}$	emf ( $\mathcal{E}$ ) = I (R + r) emk ( $\mathcal{E}$ ) = I(R + r)
$R_s = R_1 + R_2 + \dots$ $\frac{1}{R_p} = \frac{1}{R_1} + \frac{1}{R_2} + \dots$	$q = I \Delta t$
$W = Vq$ $W = VI\Delta t$ $W = I^2R\Delta t$ $W = \frac{V^2\Delta t}{R}$	$P = \frac{W}{\Delta t}$ $P = VI$ $P = I^2R$ $P = \frac{V^2}{R}$

**ALTERNATING CURRENT / WISSELSTROOM**

$I_{rms} = \frac{I_{max}}{\sqrt{2}}$ / $I_{wgk} = \frac{I_{maks}}{\sqrt{2}}$	$P_{ave} = V_{rms} I_{rms}$ / $P_{gemiddeld} = V_{wgk} I_{wgk}$
$V_{rms} = \frac{V_{max}}{\sqrt{2}}$ / $V_{wgk} = \frac{V_{maks}}{\sqrt{2}}$	$P_{ave} = I_{rms}^2 R$ / $P_{gemiddeld} = I_{wgk}^2 R$
	$P_{ave} = \frac{V_{rms}^2}{R}$ / $P_{gemiddeld} = \frac{V_{wgk}^2}{R}$