



education

Department of
Education
FREE STATE PROVINCE

PREPARATORY EXAMINATION

GRADE 12

**PHYSICAL SCIENCES P1
PHYSICS**

SEPTEMBER 2020

MARKS: 150

TIME: 3 HOURS

This question paper consists of 14 pages and 3 data sheets.

INSTRUCTIONS AND INFORMATION

1. Write your name and other information in the appropriate spaces on the ANSWER BOOK.
2. This question paper consists of NINE questions. Answer ALL questions in the ANSWER BOOK.
3. Start EACH question on a NEW page in the ANSWER BOOK.
4. Number the answers correctly according to the numbering system used in this question paper.
5. Leave ONE line between two sub-questions, for example between QUESTION 2.1 and QUESTION 2.2.
6. You may use a non-programmable pocket calculator.
7. You may use appropriate mathematical instruments.
8. Show ALL formulae and substitutions in ALL calculations.
9. Round off your FINAL numerical answers to a minimum of TWO decimal places where applicable.
10. Give brief motivations, discussions, etc. where required.
11. You are advised to use the attached DATA SHEETS.
12. Write neatly and legibly.

QUESTION 1

Four options are provided as possible answers to the following questions. Each question has only ONE correct answer. Choose the answer and write down only the letter (A–D) next to the question numbers (1.1–1.10) in the ANSWER BOOK.

1.1 A car is moving at a constant speed.

Which ONE of the following statements about the forces acting on the car is CORRECT?

- A The net force acting on the car is zero.
- B There are no forces acting on the car.
- C The weight of the car is equal to the normal force acting on the car.
- D There is a non-zero net force acting on the car. (2)

1.2 Two spheres X and Y, of masses $2m$ and m respectively, are released from the same height h . Each one of the spheres experiences an acceleration to the surface of the Earth. Ignore the effects of air resistance.

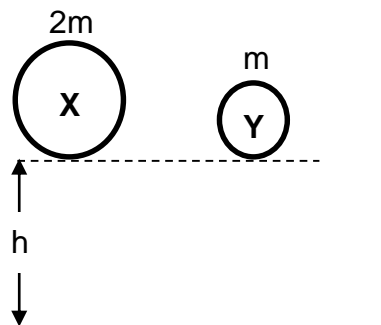

The CORRECT relationship between the acceleration of each sphere and the force acting on each sphere, is ...

| | ACCELERATION (A) | FORCE (F) |
|---|-------------------------|------------------|
| A | $a_x = a_y$ | $F_x = F_y$ |
| B | $a_x = a_y$ | $F_x > F_y$ |
| C | $a_x > a_y$ | $F_x > F_y$ |
| D | $a_x > a_y$ | $F_x = F_y$ |

(2)

1.3 A snooker ball moving with velocity v collides head-on with another snooker ball of the same mass at rest. If the collision is elastic, the velocity of the second snooker ball after the collision is:

A Zero

B $\frac{1}{2}v$

C v

D $2v$

(2)

1.4 The velocity-time graph below represents the vertical motion of an object projected upwards.

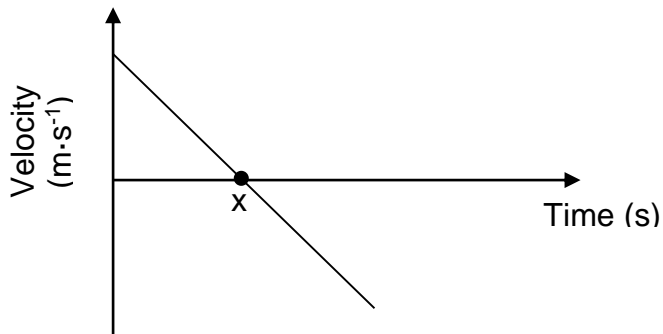

Which ONE of the following correctly describes the acceleration and displacement of the object at point **X** indicated on the graph?

| | ACCELERATION ($m \cdot s^{-2}$) | DISPLACEMENT (m) |
|---|---|-----------------------------|
| A | 9,8 | 0 |
| B | -9,8 | $-\Delta y$ |
| C | 0 | Δy |
| D | -9,8 | Δy |

(2)

- 1.5 An applied force F , accelerates an object of mass m on a horizontal frictionless surface from a velocity v to a velocity of $2v$ over a distance Δx .

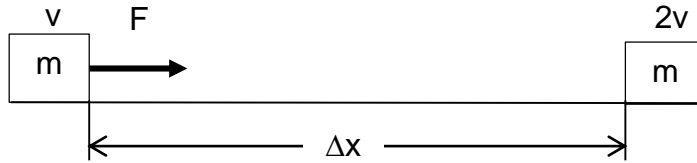

The net work done on the object is equal to ...

- A $\frac{1}{2}mv^2$.
 - B mv^2 .
 - C $\frac{3}{2}mv^2$.
 - D $2mv^2$. (2)
- 1.6 Scientists can use the absorption spectrum from distant stars to determine whether the stars are moving towards the Earth or away from the Earth.

The diagrams below shows the absorption spectrum of a gas from the sun and from four other stars, **A**, **B**, **C** and **D** as observed from the Earth.

Which star, **A**, **B**, **C** or **D** is moving away from the Earth?

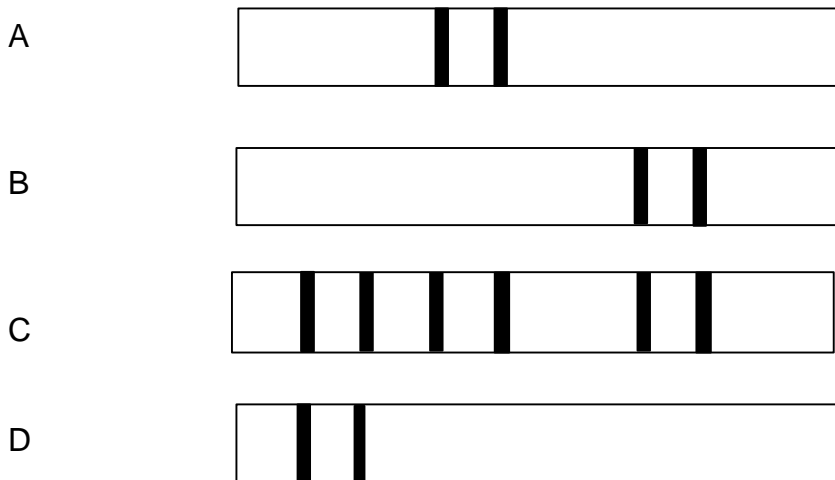
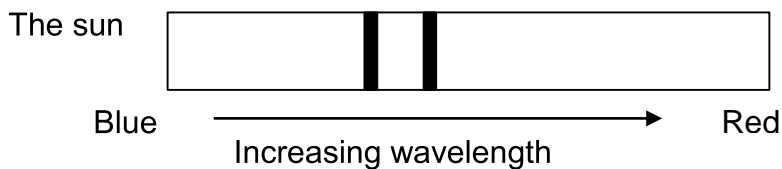

(2)

1.7 **P**, **Q** and **R** are three charged spheres. When **P** and **Q** are brought near each other, they experience an attractive force. When **Q** and **R** are brought near each other, they experience a repulsive force.

Which ONE of the following is TRUE?

- A **P** and **R** have charges with the same sign.
- B **P** and **R** have charges with opposite signs.
- C **P**, **Q** and **R** have charges with the same sign.
- D **P**, **Q** and **R** have equal charges. (2)

1.8 Which ONE of the following graphs best represents the relationship between the magnitude of the electric field (E) and the charge (Q) at a distance r from the charge?

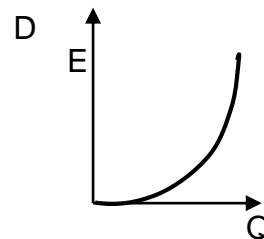
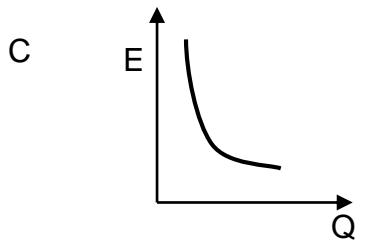
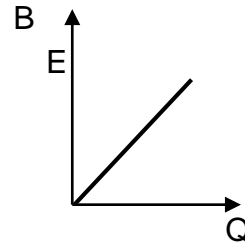
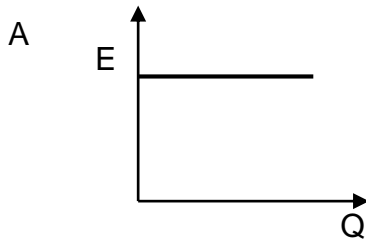

(2)

1.9 In circuit **A** and **B** shown below, all resistors and cells are IDENTICAL.

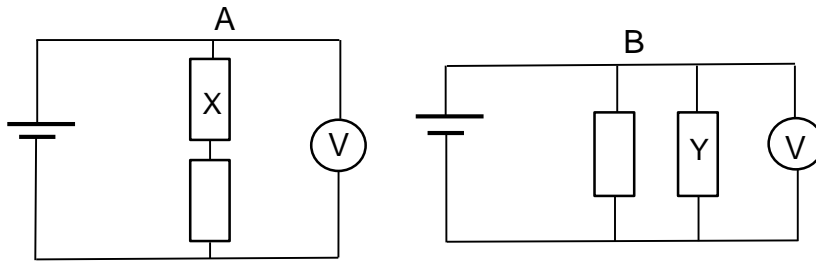

If the power dissipated by **Y** equals $4P$, then the power dissipated by **X** will be ...

- A $\frac{1}{4}P$
- B $\frac{1}{2}P$
- C P
- D $2P$

(2)

1.10 The simplified diagram of an electric motor is shown below.

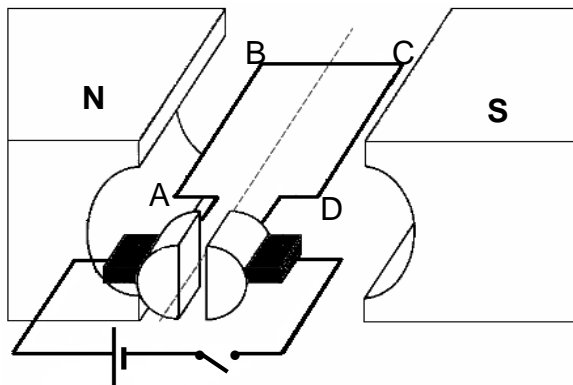

Which ONE of the following statements is TRUE?

- A Coil ABCD will rotate clockwise and mechanical energy will be converted into electrical energy.
- B Coil ABCD will rotate anti-clockwise and electrical energy will be converted into mechanical energy.
- C Coil ABCD will rotate clockwise and electrical energy will be converted into mechanical energy.
- D Coil ABCD will rotate anti-clockwise and mechanical energy will be converted into electrical energy.

(2)
[20]

QUESTION 2 (Start on a new page.)

- 2.1 A block **A** of mass 5 kg, at rest on a rough horizontal table, is connected to another block **B** of mass 10 kg by means of a light inextensible string which passes over a light frictionless pulley. A force of 120 N is applied vertically upwards on block **B** as shown in the diagram below.

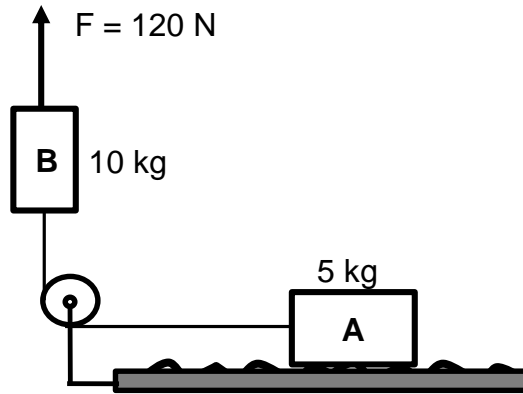

The coefficient of kinetic friction between the surface and block **A** is 0,3. Ignore the effects of air friction.

- 2.1.1 State Newton's Second Law in words. (2)
- 2.1.2 Draw a labelled free-body diagram of ALL forces acting on block **B**. (3)
- Calculate the magnitude of the:
- 2.1.3 Friction force acting on block **A** (3)
- 2.1.4 Tension force acting on block **B** (6)
- 2.2 A man on the surface of planet **Y** weighs HALF his weight compared to his weight on the surface of the Earth. The mass of planet **Y** is TWICE that of the Earth.
- 2.2.1 State Newton's Law of Universal Gravitation in words. (2)
- 2.2.2 Calculate the radius of planet **Y** in terms of the radius of the Earth. (4)

[20]

QUESTION 3 (Start on a new page.)

A helicopter is ascending vertically at a constant speed of $16 \text{ m}\cdot\text{s}^{-1}$. When reaching a height of 2 500 m above the ground, a metal ball is dropped. Ignore the effects of air resistance.

3.1 Define the term *free fall*. (2)

3.2 Name and define in words the law that explains why the ball first moves upwards immediately after it is dropped. (3)

3.3 Calculate:

3.3.1 The maximum height above the earth reached by the ball (4)

3.3.2 The height above the ground when the ball was in the air for 15 s after it was dropped (5)

3.3.3 The time it takes the ball to reach the ground (4)

3.4 Draw the position-time graph for the motion of the ball from the moment it is dropped, till it reaches the ground. Use the ground as a ZERO position.

Indicate:

- (i) The maximum height reached by the ball
 - (ii) The time the ball strikes the ground
- (3)
[21]

QUESTION 4 (Start on a new page.)

A boy and a girl of mass 80 kg and 50 kg respectively are moving on roller skates at a speed of $4 \text{ m}\cdot\text{s}^{-1}$ to the left as shown in the diagram.



The girl now pushes the boy away from her, resulting the boy to move at a velocity of $8 \text{ m}\cdot\text{s}^{-1}$ to the left.

- 4.1 State Newton's Third Law of Motion in words. (2)
 - 4.2 How does the impulse on the girl compare to that on the boy? (2)
 - 4.3 Calculate the girl's velocity immediately after pushing the boy away from her. (4)
 - 4.4 Calculate the impulse on the boy. (4)
- [12]**

QUESTION 5 (Start on a new page.)

The diagram below, not drawn to scale, shows a trolley of mass 38 kg released from rest at point **A** on an incline. **ABC** is a frictionless section and **CD** a rough section of the incline. The trolley reaches point **B** of the incline at a speed of $1,5 \text{ m}\cdot\text{s}^{-1}$.

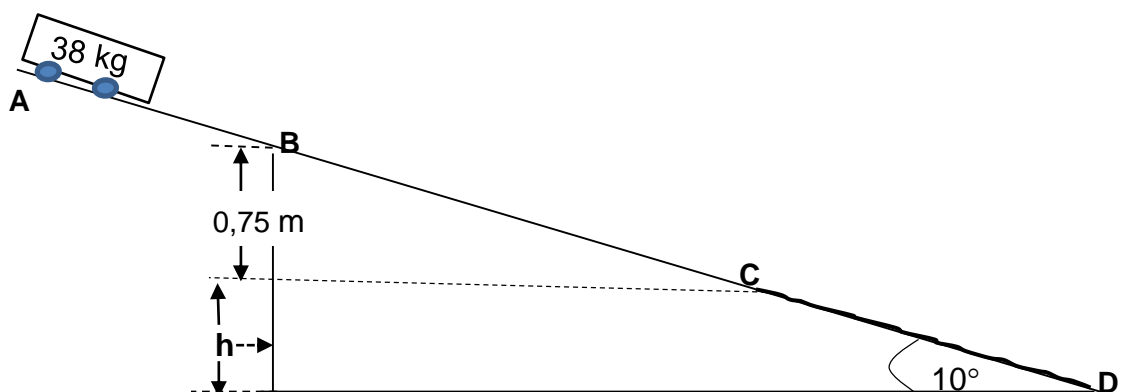

- 5.1 Define the term *non-conservative force*. (2)
- 5.2 Name the non-conservative force acting on the trolley. (1)

- 5.3 Point **C** is a point on the incline 0,75 m lower than point **B**. Calculate the speed of the trolley when it reaches point **C**. (4)

The coefficient of the kinetic friction between the trolley and the surface for section **CD** is 0,21. The trolley comes to rest at point **D**.

- 5.4 Calculate the magnitude of the kinetic frictional force acting on the trolley as it moves from point **C** to **D**. (4)

- 5.5 Use ENERGY PRINCIPLES only to calculate the height **h**. (6)
[17]

QUESTION 6 (Start on a new page.)

The siren of a stationary ambulance emits a note with a wavelength of 0,30 m. While the ambulance moves at a constant velocity, a graph is drawn from the data recorded by a detector placed next to the road a distance away from the ambulance. Take the speed of sound in air as $340 \text{ m}\cdot\text{s}^{-1}$.

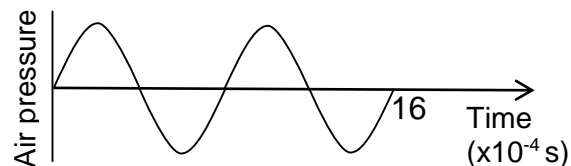

- 6.1 State the Doppler effect in words. (2)
- 6.2 Calculate the frequency of the sound emitted by the siren. (3)
- 6.3 Calculate the speed at which the ambulance is travelling. (7)
[12]

QUESTION 7 (Start on a new page.)

Three point charges, Q_1 , Q_2 , and Q_3 are arranged in space as shown in the diagram below. Q_1 and Q_2 carries charges of $+6 \mu\text{C}$ and $-3 \mu\text{C}$ respectively, and Q_3 is negatively charged with an UNKNOWN value z .

The distance between Q_3 and Q_1 is 30 cm and that between Q_3 and Q_2 is 10 cm.

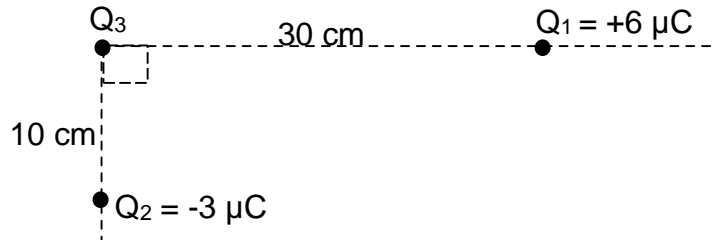

- 7.1 State Coulomb's Law in words. (2)
- 7.2 Draw the electric field pattern associated with point charges Q_1 and Q_3 . (Ignore the influence of point charge Q_2 on the field pattern.) (3)
- 7.3 Calculate the magnitude of the charge on Q_3 if the magnitude of the net force acting on point charge Q_3 due to the presence of point charges Q_1 and Q_2 , is 13,83 N. (5)
- 7.4 Define the term *electric field at a point*. (2)
- 7.5 Calculate the magnitude of the net electric field at the position of Q_3 due to charges Q_1 and Q_2 . (3)

[15]

QUESTION 8 (Start on a new page.)

In the circuit below, the battery can supply a maximum of 38,25 J of energy per 1 coulomb of charges. A high-resistance voltmeter (V) is connected across the battery. **A₁** and **A₂** represent ammeters of negligible resistance. The resistances of the connecting wires are negligible.

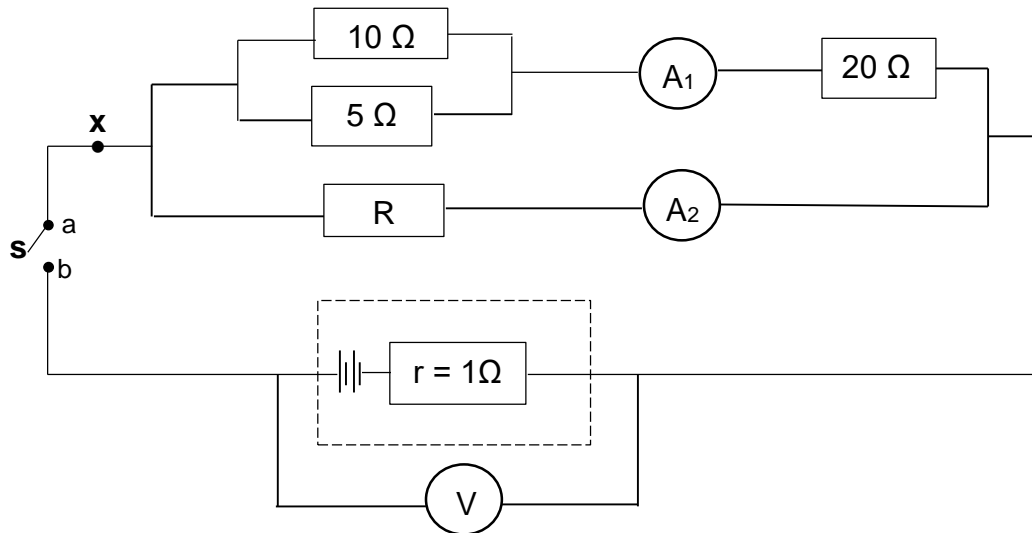

8.1 State Ohm's law in words. (2)

8.2 Give a phrase or term for the underlined words. (1)

Switch S is now closed. The potential difference across the battery now drops by 3,25 V and the 20 Ω resistor delivers a power of 45 W.

8.3 Calculate the:

8.3.1 Reading on ammeter **A₁** (3)

8.3.2 Total current in the circuit (4)

8.3.3 Resistance of **R** (7)

8.4 An additional resistor is connected at position **X** as indicated in the diagram. How will voltmeter reading V be affected?

Write down only INCREASE, DECREASE or STAYS THE SAME.

Give an explanation for your answer. (4)

[21]

QUESTION 9 (Start on a new page.)

The following diagrams show two types of generators.

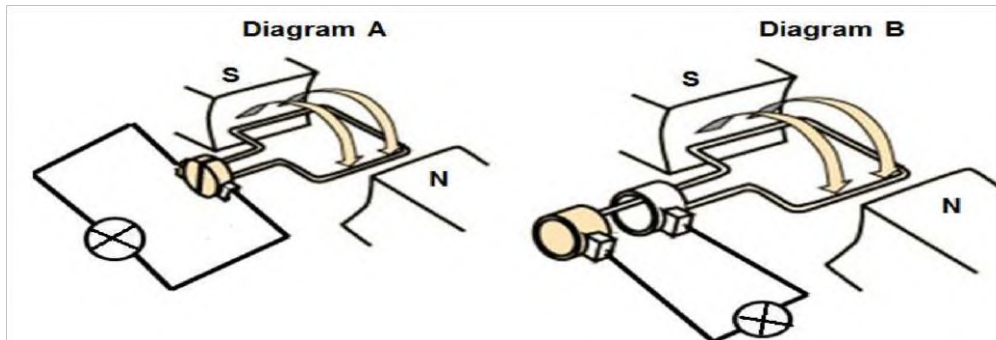

- 9.1 Name the principle on which generators operate. (1)
- 9.2 Which diagram represents a DC generator? Choose from **A** or **B**. Name the essential component that motivates your answer. (2)
- 9.3 The generator in diagram **B** induces a *rms* voltage of 220 V.
- 9.3.1 Define the term *rms voltage*. (2)
- 9.3.2 Calculate the maximum (peak) voltage induced. (3)
- 9.3.3 What influence will an increased rotational speed have on the maximum voltage induced in QUESTION 9.3.2.
Choose from INCREASE, DECREASE or STAY THE SAME. (1)
- 9.4 Draw a graph of the voltage versus time for one cycle (one complete rotation) for an AC generator. (3)
- Indicate on the graph the value of maximum (peak) voltage. (3)
- [12]**

TOTAL: 150

**DATA FOR PHYSICAL SCIENCES GRADE 12
 PAPER 1 (PHYSICS)**

**GEGEWENS VIR FISIESE WETENSKAPPE GRAAD 12
 VRAESTEL 1 (FISIKA)**

TABLE 1: PHYSICAL CONSTANTS/TABEL 1: FISIESE KONSTANTES

| NAME/NAAM | SYMBOL/SIMBOOL | VALUE/WAARDE |
|--|-----------------------|---|
| Acceleration due to gravity <i>Swaartekragversnelling</i> | g | 9,8 m·s ⁻¹ |
| Universal gravitational constant <i>Universele gravitasiekonstant</i> | G | 6,67 x 10 ⁻¹¹ N·m ² ·kg ⁻² |
| Speed of light in a vacuum <i>Spoed van lig in 'n vakuum</i> | c | 3,0 x 10 ⁸ m·s ⁻¹ |
| Planck's constant <i>Planck se konstante</i> | h | 6,63 x 10 ⁻³⁴ J·s |
| Coulomb's constant <i>Coulomb se konstante</i> | k | 9,0 x 10 ⁹ N·m ² ·C ⁻² |
| Charge on electron <i>Lading op elektron</i> | e | -1,6 x 10 ⁻¹⁹ C |
| Electron mass <i>Elektronmassa</i> | m _e | 9,11 x 10 ⁻³¹ kg |
| Mass of the Earth <i>Massa van die Aarde</i> | M | 5,98 x 10 ²⁴ kg |
| Radius of the Earth <i>Radius van die Aarde</i> | R _E | 6,38 x 10 ⁶ m |

TABLE 2: FORMULAE/TABEL 2: FORMULES

MOTION/BEWEGING

| | |
|---|---|
| $v_f = v_i + a \Delta t$ | $\Delta x = v_i \Delta t + \frac{1}{2} a \Delta t^2$ or/of $\Delta y = v_i \Delta t + \frac{1}{2} a \Delta t^2$ |
| $v_f^2 = v_i^2 + 2a\Delta x$ or/of $v_f^2 = v_i^2 + 2a\Delta y$ | $\Delta x = \left(\frac{v_i + v_f}{2} \right) \Delta t$ or/of $\Delta y = \left(\frac{v_i + v_f}{2} \right) \Delta t$ |

FORCE/KRAG

| | |
|--|---|
| $F_{\text{net}} = ma$ | $p = mv$ |
| $f_s^{\text{max}} = \mu_s N$ | $f_k = \mu_k N$ |
| $F_{\text{net}} \Delta t = \Delta p$ $\Delta p = mv_f - mv_i$ | $w = mg$ |
| $F = G \frac{m_1 m_2}{d^2}$ or/of $F = G \frac{m_1 m_2}{r^2}$ | $g = G \frac{M}{d^2}$ or/of $g = G \frac{M}{r^2}$ |

WORK, ENERGY AND POWER/ARBEID, ENERGIE EN DRYWING

| | |
|---|--|
| $W = F \Delta x \cos \theta$ | $U = mgh$ or/of $E_p = mgh$ |
| $K = \frac{1}{2} mv^2$ or/of $E_k = \frac{1}{2} mv^2$ | $W_{\text{net}} = \Delta K$ or/of $W_{\text{net}} = \Delta E_k$ $\Delta K = K_f - K_i$ or/of $\Delta E_k = E_{kf} - E_{ki}$ |
| $W_{\text{nc}} = \Delta K + \Delta U$ or/of $W_{\text{nc}} = \Delta E_k + \Delta E_p$ | $P = \frac{W}{\Delta t}$ |
| $P_{\text{av}} = Fv_{\text{av}}$ / $P_{\text{gemid}} = Fv_{\text{gemid}}$ | |

WAVES, SOUND AND LIGHT/GOLWE, KLANK EN LIG

| | |
|--|---|
| $v = f \lambda$ | $T = \frac{1}{f}$ |
| $f_L = \frac{v \pm v_L}{v \pm v_s} f_s$ $f_L = \frac{v \pm v_L}{v \pm v_b} f_b$ | $E = hf$ or /of $E = h \frac{c}{\lambda}$ |
| $E = W_o + E_{k(\text{max})}$ or/of $E = W_o + K_{\text{max}}$ where/waar | |
| $E = hf$ and/en $W_o = hf_o$ and/en $E_{k(\text{max})} = \frac{1}{2} mv_{\text{max}}^2$ or/of $K_{\text{max}} = \frac{1}{2} mv_{\text{max}}^2$ | |

ELECTROSTATICS/ELEKTROSTATIKA

| | |
|---|----------------------|
| $F = \frac{kQ_1Q_2}{r^2}$ | $E = \frac{kQ}{r^2}$ |
| $V = \frac{W}{q}$ | $E = \frac{F}{q}$ |
| $n = \frac{Q}{e}$ or/of $n = \frac{Q}{q_e}$ | |

ELECTRIC CIRCUITS/ELEKTRIESE STROOMBANE

| | |
|--|---|
| $R = \frac{V}{I}$ | emf (\mathcal{E}) = $I(R + r)$ emk (\mathcal{E}) = $I(R + r)$ |
| $R_s = R_1 + R_2 + \dots$ $\frac{1}{R_p} = \frac{1}{R_1} + \frac{1}{R_2} + \dots$ | $q = I \Delta t$ |
| $W = Vq$ $W = VI \Delta t$ $W = I^2R \Delta t$ $W = \frac{V^2 \Delta t}{R}$ | $P = \frac{W}{\Delta t}$ $P = VI$ $P = I^2R$ $P = \frac{V^2}{R}$ |

ALTERNATING CURRENT/WISSELSTROOM

| | |
|--|---|
| $I_{rms} = \frac{I_{max}}{\sqrt{2}}$ / $I_{wgk} = \frac{I_{maks}}{\sqrt{2}}$ | $P_{ave} = V_{rms} I_{rms}$ / $P_{gemiddeld} = V_{wgk} I_{wgk}$ |
| $V_{rms} = \frac{V_{max}}{\sqrt{2}}$ / $V_{wgk} = \frac{V_{maks}}{\sqrt{2}}$ | $P_{ave} = I_{rms}^2 R$ / $P_{gemiddeld} = I_{wgk}^2 R$ |
| | $P_{ave} = \frac{V_{rms}^2}{R}$ / $P_{gemiddeld} = \frac{V_{wgk}^2}{R}$ |



education

Department of
Education
FREE STATE PROVINCE

**PREPARATORY EXAMINATION
VOORBEREIDENDE EKSAMEN**

GRADE/GRAAD 12

**PHYSICAL SCIENCE: PHYSICS (P1)
FISIESE WETENSKAPPE: FISIKA (V1)**

SEPTEMBER 2020

MARKS/PUNTE: 150

**MARKING GUIDELINES
NASIENRIGLYNE**

**These marking guidelines consist of 18 pages.
Hierdie nasienriglyne bestaan uit 18 bladsye.**

QUESTION/VRAAG 1

- 1.1 A ✓✓ (2)
- 1.2 B ✓✓ (2)
- 1.3 C ✓✓ (2)
- 1.4 D ✓✓ (2)
- 1.5 C ✓✓ (2)
- 1.6 B ✓✓ (2)
- 1.7 B ✓✓ (2)
- 1.8 B ✓✓ (2)
- 1.9 C ✓✓ (2)
- 1.10 B ✓✓ (2)
- [20]**

QUESTION/VRAAG 2

- 2.1.1 When a resultant/net force acts on an object, the object will accelerate in the direction of the force at an acceleration directly proportional to the force ✓ and inversely proportional to the mass of the object. ✓
Wanneer 'n resulterende krag/netto krag op 'n voorwerp inwerk, sal die voorwerp in die rigting van die krag versnel wat direk eweredig is aan die krag en omgekeerd eweredig aan die massa van die voorwerp.

OR/OF

The net or resultant force acting on an object is equal to the rate of change of momentum of the object in the direction of the net force. ✓✓ (2 or 0)
Die netto/resultierende krag wat op 'n voorwerp inwerk, is gelyk aan die tempo van die verandering van momentum van die voorwerp in die rigting van die netto krag. (2)

2.1.2

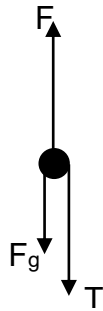

(3)

| Accept the following symbols/Aanvaar die volgende simbole | | |
|---|---|---|
| F | F _{applied} /Force applied/ <i>Toegepaste krag</i> /F _A | ✓ |
| F _g | w / F _w / weight / <i>gewig</i> | ✓ |
| T | F _T / Tension/ <i>Spanning</i> | ✓ |

NOTE/LET WEL:

- Mark awarded for label and arrow./Punt word toegeken vir byskrif en pyltjie.
- Do not penalise for length of arrow since drawing is not to scale. *Moenie vir die lengte van pyltjies penalseer nie omdat diagram nie volgens skaal geteken is nie.*
- Any additional force(s)./Enige addisionele krag(te): $\frac{2}{3}$
- If force(s) do not make contact with body./Indien krag(te) nie met die voorwerp kontak maak nie: $\frac{2}{3}$
- No labels/Geen byskrifte: $\frac{0}{3}$

2.1.3 Option/Opsie 1

$$\begin{aligned}
 f_k &= \mu_k N \checkmark \\
 &= \mu_k mg \\
 &= 0,3 \times 5 \times 9,8 \checkmark \\
 &= 14,7 \text{ N } \checkmark
 \end{aligned}$$

Option/Opsie 2

| |
|---|
| $ \begin{aligned} N &= mg \\ &= 5 \times 9,8 \\ &= 49 \end{aligned} $ |
| $ \begin{aligned} f_k &= \mu_k N \checkmark \\ &= 0,3 \times 49 \checkmark \\ &= 14,7 \text{ N } \checkmark \end{aligned} $ |

(3)

2.1.4 POSITIVE MARKING FROM 2.1.3/POSITIEWE NASIEN VANAF 2.1.3

Option/Opsie 1

Direction of motion as positive/Rigting van beweging as positief

$$\begin{aligned}
 F_{\text{net}} &= ma \quad \checkmark \\
 F + F_g + T &= ma \\
 120 - 10 \times 9,8 - T &= 10a \\
 22 - T &= 10a \\
 \\
 F_{\text{net}} &= ma \\
 T - f_k &= ma \\
 T - 14,7 &= 5a \\
 a &= 0,487 \\
 T - 14,7 &= 5(0,487) \quad \checkmark \\
 T &= 17,13 \text{ N} \quad \checkmark \\
 \text{OR} \\
 T &= 22 - 10a \\
 &= 22 - 10(0,487) \\
 &= 17,13 \text{ N}
 \end{aligned}$$

Notes/Aantekeninge:

- ✓ Formula/Formule
- ✓✓ Substitution for forces/
Vervanging van kragte
- ✓ Substitution for both
masses/Vervanging vir beide
massas
- ✓ Equating Tension forces/
Vergelyk spanningskragte
- ✓ Answer with units/Antwoord
met eenhede

(6)

Option/Opsie 2

Direction of motion as negative/Bewegingsrigting as negatief

$$\begin{aligned}
 F_{\text{net}} &= ma \quad \checkmark \\
 F + F_g + T &= ma \\
 10 \times 9,8 + T - 120 &= -10a \\
 T - 22 &= -10a \\
 \\
 F_{\text{net}} &= ma \\
 f_k - T &= -ma \\
 14,7 - T &= -5a \\
 a &= 0,487 \\
 14,7 - T &= -5(0,487) \quad \checkmark \\
 -T &= -17,13 \\
 T &= 17,13 \text{ N} \quad \checkmark \\
 \text{OR} \\
 T - 22 &= -10a \\
 T &= 22 - 10(0,487) \\
 &= 17,13 \text{ N}
 \end{aligned}$$

- 2.2.1 Each body in the universe attracts every other body with a force that is directly proportional to the product of their masses ✓ and inversely proportional to the square of the distance between their centres. ✓ (2)
Elke liggaam in die heelal trek elke ander liggaam aan met 'n krag wat direk eweredig is aan die produk van hul massas ✓ *en omgekeerd eweredig is aan die kwadraat van die afstand tussen hul middelpunte.* ✓

2.2.2 $F_{\text{planet/planeet}} = \frac{1}{2} F_{\text{earth/aarde}}$ ✓

$$G \frac{M_m 2M_e}{(X)^2} = \frac{1}{2} G \frac{M_m M_e}{R^2} \quad \checkmark$$

$$4R^2 = (X)^2$$

$$2R = X \quad \checkmark$$

Notes/Aantekeninge:

- ✓ ✓ Formula of Gravitational law applied for each object.
Formule van Gravitasiwet wat vir elke voorwerp toegepas word.

- ✓ Relationship between F_{planet} and F_{earth} .
Verhouding tussen F_{planeet} en F_{aarde}

- ✓ Answer/Antwoord

(4)
[20]

QUESTION/VRAAG 3

- 3.1 Motion of an object under the influence of gravity/gravitational force/weight only. ✓✓ (2 or 0)
Beweging van 'n voorwerp slegs onder die invloed van gravitasie/gravitasiekrag/gewig.

OR/OF

Motion in which the only force acting on the object is gravity/gravitational force/weight.
Beweging waartydens die enigste krag wat inwerk gravitasie/gravitasiekrag/gewig is.

ACCEPT/AANVAAR

An object that is launched (or synonyms) with an initial velocity under the influence of the force of gravity only.
'n Voorwerp wat gegooi (of sinonieme) word met 'n aanvanklike snelheid onder die invloed van slegs gravitasiekrag. (2)

- 3.2 Newton's First Law/*Newton se Eerste Wet* ✓
 A body will remain in its state of rest or motion at a constant velocity unless a non-zero net/resultant force acts on it. ✓✓
'n Voorwerp sal in sy posisie van rus of beweging bly teen 'n konstante snelheid tensy 'n nie-nul netto/resulterende krag daarop inwerk. (3)

- 3.3.1 **OPTION/OPSIE 1** ↑ + Positive/Positief **OPTION/OPSIE 2** ↑ - Negative/Negatief

| | | |
|---|--|-----|
| $v_f^2 = v_i^2 + 2a\Delta y \checkmark$ $0 = (16)^2 + 2(-9,8)\Delta y \checkmark$ $\Delta y = 13,06$ Height/ <i>Hoogte</i> = $13,06 + 2500$ = 2513,06 m ✓ | $v_f^2 = v_i^2 + 2a\Delta y \checkmark$ $0 = (-16)^2 + 2(9,8)\Delta y \checkmark$ $\Delta y = -13,06$ Height/ <i>Hoogte</i> = $13,06 + 2500$ = 2513,06 m ✓ | (4) |
|---|--|-----|

| | | |
|--|---|-----|
| <p>3.3.2 Option/Opsie 1</p> Whole motion ↑ Positive <i>Algehele beweging</i> ↑ <i>Positief</i> $\Delta y = v_i\Delta t + \frac{1}{2}a\Delta t^2 \checkmark$ $= 16(15) + \frac{1}{2}(-9,8)(15)^2 \checkmark$ $= -862,5$ Height/ <i>Hoogte</i> = $2500 - 862,5$ ✓ = 1637,5 m ✓ | <p style="text-align: center;">Option/Opsie 2</p> Whole motion ↑ Negative <i>Algehele beweging</i> ↑ <i>Negatief</i> $\Delta y = v_i\Delta t + \frac{1}{2}a\Delta t^2 \checkmark$ $= -16(15) + \frac{1}{2}(9,8)(15)^2 \checkmark$ $= 862,5$ Height/ <i>Hoogte</i> = $2500 - 862,5$ ✓ = 1637,5 m ✓ | (5) |
|--|---|-----|

Option/Opsie 3

Motion from the maximum height. ↓ Positive
 Beweging vanaf die maksimum hoogte. ↓ Positief

$$\begin{aligned}
 V_f &= v_i + g\Delta t \\
 0 &= 16 - 9,8\Delta t \\
 \Delta t &= 1,63 \text{ s} \\
 \\
 \Delta y &= v_i\Delta t + \frac{1}{2}a\Delta t^2 \checkmark \\
 &= 0 + \frac{1}{2}(9,8)(13,37)^2 \checkmark \\
 &= 875,56 \\
 \text{Height/Hoogte} &= 2513,06 - 875,56 \checkmark \\
 &= 1637,5 \text{ m} \checkmark
 \end{aligned}$$

Option/Opsie 4

Motion from the maximum height. ↓ Negative
 Beweging vanaf die maksimum hoogte. ↓ Negatief

$$\begin{aligned}
 V_f &= v_i + g\Delta t \\
 0 &= 16 - 9,8\Delta t \\
 \Delta t &= 1,63 \text{ s} \\
 \\
 \Delta y &= v_i\Delta t + \frac{1}{2}a\Delta t^2 \checkmark \\
 &= 0 + \frac{1}{2}(-9,8)(13,37)^2 \checkmark \\
 &= -875,56 \\
 \text{Height/Hoogte} &= 2513,06 - 875,56 \checkmark \\
 &= 1637,5 \text{ m} \checkmark
 \end{aligned}$$

Option/Opsie 5

Motion point of projection down. ↓ Positive
 Bewegingspunt van afwaartse projeksie. ↓ Positief

$$\begin{aligned}
 V_f &= v_i + g\Delta t \\
 0 &= 16 - 9,8\Delta t \\
 \Delta t &= 1,63 \text{ s} \\
 \\
 \Delta y &= v_i\Delta t + \frac{1}{2}a\Delta t^2 \checkmark \\
 &= 16(11,73) + \frac{1}{2}(9,8)(11,73)^2 \checkmark \\
 &= -862,5 \\
 \text{Height/Hoogte} &= 2500 - 862,5 \checkmark \\
 &= 1637,5 \text{ m} \checkmark \\
 \text{RANGE/GEBIED:} & 1637,5 - 1638,1 \text{ m}
 \end{aligned}$$

Option/Opsie 6

Motion point of projection down. ↓ Negative
 Bewegingspunt van afwaartse projeksie. ↓ Negatief

$$\begin{aligned}
 V_f &= v_i + g\Delta t \\
 0 &= 16 - 9,8\Delta t \\
 \Delta t &= 1,63 \text{ s} \\
 \\
 \Delta y &= v_i\Delta t + \frac{1}{2}a\Delta t^2 \checkmark \\
 &= -16(11,73) + \frac{1}{2}(-9,8)(11,73)^2 \checkmark \\
 &= -862,5 \\
 \text{Height/Hoogte} &= 2500 - 862,5 \checkmark \\
 &= 1637,5 \text{ m} \checkmark
 \end{aligned}$$

3.3.3 **OPTION/OPSIE 1**

Whole motion ↑ +
Algehele beweging

$$\Delta y = v_i \Delta t + \frac{1}{2} a \Delta t^2 \checkmark$$

$$-2500 = 16 \Delta t + \frac{1}{2} (-9,8) \Delta t^2 \checkmark$$

$$\Delta t = 24,34 \text{ s } \checkmark$$

OPTION/OPSIE 2

Whole motion ↑ -
Algehele beweging

$$\Delta y = v_i \Delta t + \frac{1}{2} a \Delta t^2 \checkmark$$

$$2500 = -16 \Delta t + \frac{1}{2} (9,8) \Delta t^2 \checkmark$$

$$\Delta t = 24,34 \text{ s } \checkmark$$

Note: For options 3 and 4 use any of the equations of motion containing Δt to calculate Δt and substitute into equation of $\Delta y = v_i \Delta t + \frac{1}{2} g \Delta t^2$.

Aantekening: Vir opsies 3 en 4, gebruik enige van die bewegingsvergelings wat Δt bevat om Δt te bereken en vervang in vergelyking van $\Delta y = v_i \Delta t + \frac{1}{2} g \Delta t^2$.

- 1) $v_f = v_i + g \Delta t$ $\Delta t = 1,633 \text{ s}$
- 2) $\Delta y = \left(\frac{v_f + v_i}{2} \right) \Delta t$ $\Delta y = 13,061 \text{ m}$; Max height/Maks hoogte = 2513,06 m
- 3) $\Delta y = v_i \Delta t + \frac{1}{2} g \Delta t^2$ $\Delta y = 13,061 \text{ m}$; Max height/Maks hoogte = 2513,06 m

OPTION/OPSIE 3

Motion from maximum height ↑ +
Beweging vanaf maksimum hoogte

$$v_f = v_i + a \Delta t$$

$$0 = 16 + (-9,8) \Delta t$$

$$\Delta t = 1,63 \text{ s}$$

$$\Delta y = v_i \Delta t + \frac{1}{2} a \Delta t^2 \checkmark$$

$$-2513,06 = 0 \Delta t + \frac{1}{2} (-9,8) \Delta t^2 \checkmark$$

$$\Delta t = 22,65 \text{ s}$$

$$\Delta t = 22,65 + 1,63$$

$$= 24,28 \text{ s } \checkmark$$

OPTION/OPSIE 4

Motion from maximum height ↑ -
Beweging vanaf maksimum hoogte

$$v_f = v_i + a \Delta t$$

$$0 = -16 + (9,8) \Delta t$$

$$\Delta t = 1,63 \text{ s}$$

$$\Delta y = v_i \Delta t + \frac{1}{2} a \Delta t^2 \checkmark$$

$$2513,06 = 0 \Delta t + \frac{1}{2} (9,8) \Delta t^2 \checkmark$$

$$\Delta t = 22,65 \text{ s}$$

$$\Delta t = 22,65 + 1,63$$

$$= 24,28 \text{ s } \checkmark$$

(4)

3.4 **POSITIVE MARKING FROM 3.3.3/POSITIEWE NASIEN VANAF 3.3.3**

Take Ground as zero position/Neem grond as zero-posisie

Upward motion as positive./Opwaartse beweging as positief.

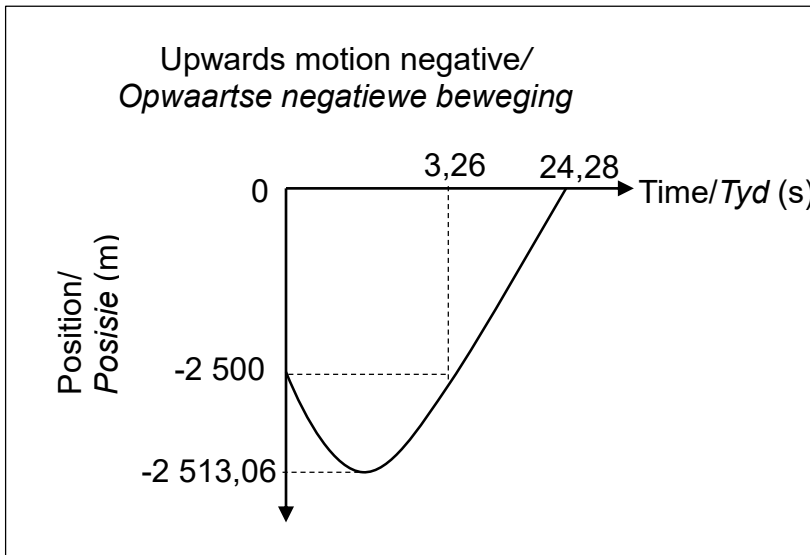
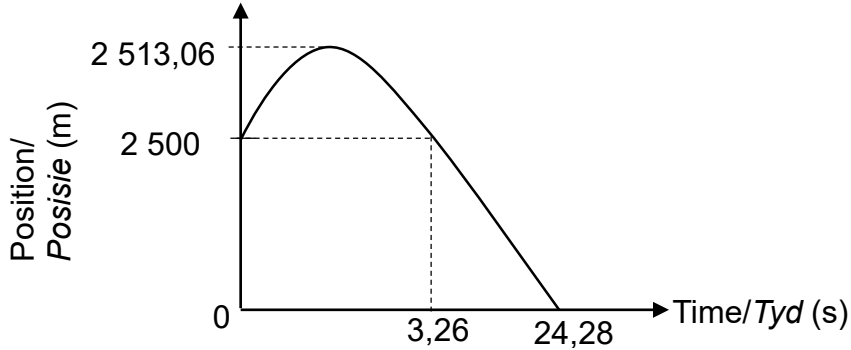

Marking criteria/Nasienriglyne

| | |
|--|---|
| Graph with correct shape, starts at 2 500 and ends on x axis at t_f (24,28 s). Grafiek met korrekte vorm begin by 2 500 en eindig op x-as by t_f (24,28 s). | ✓ |
| Maximum height/Maksimum hoogte (2513,06) | ✓ |
| Time of/Tyd van 24,28 | ✓ |

(3)
[21]

QUESTION/VRAAG 4

4.1 When object A exerts a force on object B, object B will simultaneously exert an oppositely directed force of equal magnitude on object A. ✓✓ (2 or 0)
Wanneer voorwerp A 'n krag op B uitoefen, sal voorwerp B terselfdertyd 'n krag in die teenoorgestelde rigting, van gelyke grootte op voorwerp A uitoefen. (2)

4.2 Equal in magnitude ✓ and opposite in direction. ✓
Gelyk in grootte en rigting is teenoorgesteld. (2)

4.3 **Motion to the left/Beweging na links (+)**

$$\left. \begin{aligned} \Sigma P_f &= \Sigma P_i \\ (m_B + m_G)v_{iBG} &= m_B v_{fB} + m_G v_{fG} \\ (80 + 50)(4) &= 80(8) + 50v_{fG} \end{aligned} \right\} \text{Any/Enige } \checkmark$$
$$v_{fG} = 2,40 \text{ m} \cdot \text{s}^{-1} \text{ to the right/backwards } \checkmark$$

na regs/terugwaarts (4)

Motion to the left/Beweging na links (-)

$$\left. \begin{aligned} \Sigma P_f &= \Sigma P_i \\ (m_B + m_G)v_{iBG} &= m_B v_{fB} + m_G v_{fG} \\ (80 + 50)(-4) &= 80(-8) + 50v_{fG} \end{aligned} \right\}$$
$$v_{fG} = 2,40 \text{ m} \cdot \text{s}^{-1} \text{ to the right/backwards } \checkmark$$

na regs/terugwaarts

4.4 **OPTION/OPSIE 1:**
Motion to left/Beweging na links +

$$\begin{aligned} F_{\text{net}}\Delta t &= \Delta p \text{ (boy/seun)} \\ &= m(v_{fB} - v_{iB}) \quad \left. \vphantom{F_{\text{net}}\Delta t} \right\} \text{Any/Enige } \checkmark \\ &= 80(8 - 4) \checkmark \\ &= 320 \checkmark \text{ N}\cdot\text{s to the left/na links } \checkmark \end{aligned}$$

OR/OF

**POSITIVE MARKING FROM 4.3/
 POSITIEWE NASIEN VANAF 4.3**

$$\begin{aligned} F_{\text{net}}\Delta t &= \Delta p \text{ (girl/dogter)} \quad \left. \vphantom{F_{\text{net}}\Delta t} \right\} \text{Any/Enige } \checkmark \\ &= m(v_{fB} - v_{iB}) \checkmark \\ &= 50(-2,4 - 4) = -320 \\ &= 320 \text{ N}\cdot\text{s to the right/} \\ &\quad \text{na regs } \checkmark \end{aligned}$$

$$F_{\text{net}}\Delta t \text{ (boy/seun)} = 320 \text{ N}\cdot\text{s to the } \checkmark \\ \text{left/na links}$$

OPTION/OPSIE 2:
Motion to right/Beweging na regs (+)

$$\begin{aligned} F_{\text{net}}\Delta t &= \Delta p \text{ (boy/seun)} \quad \left. \vphantom{F_{\text{net}}\Delta t} \right\} \text{Any/Enige } \checkmark \\ &= m(v_{fB} - v_{iB}) \\ &= 80(-8 - (-4)) \checkmark \\ &= -320 \\ &= 320 \checkmark \text{ N}\cdot\text{s to the left/na links } \checkmark \end{aligned}$$

OR/OF

**POSITIVE MARKING FROM 4.3/
 POSITIEWE NASIEN VANAF 4.3**

$$\begin{aligned} F_{\text{net}}\Delta t &= \Delta p \text{ (girl/dogter)} \quad \left. \vphantom{F_{\text{net}}\Delta t} \right\} \text{Any/Enige } \checkmark \\ &= m(v_{fB} - v_{iB}) \\ &= 50(2,4 - (-4)) \checkmark \\ &= 320 \text{ N}\cdot\text{s to the right/na regs} \end{aligned}$$

$$F_{\text{net}}\Delta t \text{ (boy/seun)} = 320 \checkmark \text{ N}\cdot\text{s to the } \checkmark \\ \text{left/na links}$$

(4)
[12]

QUESTION/VRAAG 5

5.1 A force for which the work done in moving an object between two points is dependent of the path taken. $\checkmark\checkmark$ (2 or 0)
'n Krag waarvoor die arbeid wat verrig is om 'n voorwerp tussen twee punte te beweeg, afhanklik is van die pad wat gevolg word. (2)

5.2 Frictional (force)/Wrywing (krag) \checkmark (1)

5.3 **Option/Opsie 1**

$$\begin{aligned} (U + K)_i &= (U + K)_f \\ mgh_i + \frac{1}{2}mv_i^2 &= mgh_f + m \frac{1}{2}mv_f^2 \quad \left. \vphantom{(U + K)_i} \right\} \text{Any/Enige } \checkmark \end{aligned}$$

$$\begin{aligned} (38)(9,8)(0,75) + \frac{1}{2} 38(1,5)^2 &= 9,8(0) + \frac{1}{2} 38v_f^2 \checkmark \\ v_f &= 4,12 \text{ m}\cdot\text{s}^{-1} \checkmark \end{aligned} \quad (4)$$

Option/Opsie 2

$$\begin{aligned} W_{nc} &= \Delta U + \Delta K \\ &= mg(h_f - h_i) + \frac{1}{2}m(v_f^2 - v_i^2) \quad \left. \vphantom{W_{nc}} \right\} \text{Any/Enige } \checkmark \end{aligned}$$

$$0 = 38(9,8)(0 - 0,75) + \frac{1}{2}(38)(v_f^2 - 1,5^2) \checkmark$$

$$v_f = 4,12 \text{ m}\cdot\text{s}^{-1} \checkmark$$

5.4

$$\left. \begin{aligned} f_k &= \mu_k N \\ &= \mu_k mg \cos \theta \\ &= 0,21(38)(9,8) \cos 10^\circ \\ &= 77,02 \text{ N} \end{aligned} \right\} \text{Any/Enige } \checkmark$$

(4)

5.5 **POSITIVE MARKING 5.3 AND 5.4/POSITIEWE NASIEN 5.3 EN 5.4**

Option/Opsie 1

$$\left. \begin{aligned} W_{\text{net}} &= \Delta K \\ W_f + W_{\text{fg}} &= \frac{1}{2}m(v_f^2 - v_i^2) \\ f_k \Delta x \cos \theta + mg \sin \theta \Delta x \cos \theta &= \frac{1}{2}m(v_f^2 - v_i^2) \end{aligned} \right\} \text{Any/Enige } \checkmark$$

$$\underline{77,016 \Delta x \cos 180^\circ + 38 \times 9,8 \sin 10^\circ \Delta x \cos 0^\circ} = \frac{1}{2}(38)(0 - 4,12^2) \checkmark$$

$$-12,35 \Delta x = -322,514$$

$$\Delta x = 26,11$$

$$\sin 10^\circ = \frac{h}{\Delta x}$$

$$= \frac{h}{26,11}$$

$$h = 4,535 \text{ m } \checkmark$$

(6)
[17]

QUESTION/VRAAG 6

- 6.1 It is the (apparent) change in frequency (or pitch) of the sound (detected by a listener) ✓ because the sound source and the listener have different velocities relative to the medium of sound propagation. ✓
Dit is die (waarskynlike) verandering in frekwensie (of toonhoogte) van die klank (soos waageneem deur 'n luisteraar) omdat die bron van die klankgolf en die waarnemer verskillende snelhede het relatief tot die medium van klankvoortplanting. (2)

OR/OF

An (apparent) change in (observed/detected) frequency (pitch), (wavelength) ✓ as a result of the relative motion between a source and an observer ✓ (listener).
'n (Waarskynlike) verandering in (waargenome) frekwensie (toonhoogte), (golflengte) as 'n gevolg van die relatiewe beweging tussen die bron en die waarnemer (luisteraar).

6.2 $v = f\lambda$ ✓
 $340 = f(0,3)$ ✓
 $f = 1133,33 \text{ Hz}$ ✓ (3)

6.3 **POSITIVE MARKING FROM 6.2/POSITIEWE NASIEN VANAF 6.2**

$$f = \frac{1}{T} \checkmark \quad \text{OR/OF} \quad f = \frac{\text{waves/golwe}}{\text{Time/tyd}} \checkmark$$
$$= \frac{1}{8 \times 10^{-4}} \checkmark \quad = \frac{2}{16 \times 10^{-4}} \checkmark$$
$$= 1250 \text{ Hz}$$
$$f_L = \left(\frac{v \pm v_L}{v \pm v_S} \right) f_s \checkmark \quad \text{OR/OF} \quad f_L = \left(\frac{v}{v - v_S} \right) f_s$$
$$1250 \checkmark = \left(\frac{340}{340 - v_S} \right) 1133,33 \checkmark$$
$$v_S = 31,73 \text{ m} \cdot \text{s}^{-1} \checkmark$$

(7)
[12]

QUESTION/VRAAG 7

- 7.1 The electrostatic force of attraction or repulsion between two point charges is directly proportional to the product (of the magnitudes) of the charges and inversely proportional to the square of the distance between them. ✓
Die elektrostatische aantrekkingskrag of afstootkrag tussen twee puntladings is direk eweredig aan die produk (van die groottes) van die ladings en omgekeerd eweredig aan die kwadraat van die afstand tussen hulle. (2)

NOTE/LET WEL:

-1 for every key word/phrase omitted. If **masses** used instead of charges, **0/2**.
-1 vir elke sleutelwoord/frase wat uitgelaat is. Indien **massas** en nie ladings gebruik word nie, **0/2**.

7.2

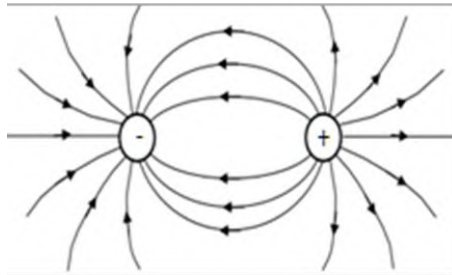

Marking criteria/Nasienkriteria

| | |
|--|---|
| Correct direction away from the + sphere/Korrekte rigting weg van die + sfeer | ✓ |
| Shape of the electric field/Vorm van die elektriese veld | ✓ |
| Field lines starting on the sphere and not crossing/Veldlyne begin op die sfeer en kruis nie | ✓ |

(3)

7.3

$$F = \frac{kQ_1Q_2}{r^2} \checkmark$$

$$F_{13} = \frac{kQ_1Q_2}{r^2} = \frac{9 \times 10^9 (6 \times 10^{-6})z}{(30 \times 10^{-2})^2} \checkmark$$
$$= 6 \times 10^5 z$$

$$F_{23} = \frac{kQ_2Q_3}{r^2} = \frac{9 \times 10^9 (3 \times 10^{-6})z}{(10 \times 10^{-2})^2} \checkmark$$
$$= 27 \times 10^5 z$$

$$F_{\text{net}}^2 = F_{13}^2 + F_{23}^2$$
$$(13,83)^2 = (6 \times 10^5 z)^2 + (27 \times 10^5 z)^2 \checkmark$$
$$z = 5 \times 10^{-6} \text{ C} \checkmark \quad (5)$$

- 7.4 The electric field at a point is the (electrostatic) force experienced per unit positive charge placed at that point.
Die elektriese veld op 'n punt is die (elektrostatiese) krag wat ervaar word per eenheid positiewe lading wat op daardie punt geplaas word. (2)

NOTE/LET WEL:

- 1 for every key word omitted.
- 1 vir elke sleutelwoord wat uitgelaat is.

7.5

$$E_{\text{NET}} = \frac{F_{\text{NET}}}{q} \checkmark$$
$$= \frac{13,83}{5 \times 10^{-6}} \checkmark$$
$$= 2,77 \times 10^6 \text{ N.C}^{-1} \checkmark \quad (3)$$

[15]

QUESTION/VRAAG 8

8.1 Potential difference across a conductor is directly proportional to the current ✓ in the conductor provided the temperature is constant. ✓
Potensiaalverskil oor 'n geleier is direk eweredig aan die stroom in die geleier mits die temperatuur konstant is. (2)

8.2 Emf of the battery/Emk van die battery ✓ (1)

8.3.1 **Option/Opsie 1**

$$P = I^2 R \checkmark$$

$$45 = I^2 (20) \checkmark$$

$$I = 1,5 A \checkmark$$

Option/Opsie 2

$$P = \frac{V^2}{R}$$

$$45 = \frac{V^2}{20}$$

$$V = 30$$

$$R = \frac{V}{I} \checkmark$$

$$20 = \frac{30}{I} \checkmark$$

$$I = 1,5 A \checkmark$$

(3)

8.3.2 **Option/Opsie 1**

$$V_{\text{lost}} = Ir \checkmark$$

$$3,25 \checkmark = I(1) \checkmark$$

$$I = 3,25 A \checkmark$$

Option/Opsie 2

$$\text{Emf/Emk} = IR + Ir \checkmark$$

$$38,25 \checkmark = 35 + I(1) \checkmark$$

$$I = 3,25 A \checkmark$$

(4)

8.3.3 **POSITIVE MARKING FROM 8.3.1 & 8.3.2**
POSITIEWE NASIEN VANAF 8.3.1 & 8.3.2

Option/Opsie 1

$$\text{Emf} = I(R_p + r) \checkmark$$

$$38,25 \checkmark = 3,25(R_p + 1) \checkmark$$

$$R_p = 10,77 \Omega$$

$$\frac{1}{R_p} = \frac{1}{R} + \frac{1}{R_{20+I}}$$

$$\checkmark \frac{1}{10,77} = \frac{1}{R} + \frac{1}{23,33} \checkmark \checkmark$$

$$\frac{1}{R} = 0,05$$

$$R = 20 \Omega \checkmark$$

Option/Opsie 2

$$V_p = V_{\text{Ext}}$$

$$= 38,25 - 3,25 \checkmark$$

$$= 35V$$

$$V_p = IR_p \checkmark$$

$$35 = 3,25 R_p \checkmark$$

$$R_p = 10,77 \Omega$$

Option/Opsie 3

$$V_{20\Omega} = IR$$

$$= 1,5(20) \checkmark$$

$$= 30V$$

$$V_p = V_{20\Omega} + V_{5\Omega}$$

$$= 30 + 5$$

$$= 35V$$

(7)

- 8.4 Increase ✓
Total resistance in circuit increase and the total current decrease. ✓
 V_{internal} will decrease. ✓
Therefore: V_{external} will increase ✓ (because emf stays constant).

Toeneem

Totale weerstand in stroombaan neem toe en die totale stroom neem af.

V_{intern} sal afneem.

Daarom: V_{ekstern} sal toeneem (omdat emk konstant bly).

(4)

[21]

QUESTION/VRAAG 9

- 9.1 Generators: Electromagnetic induction ✓
Generators: Elektromagnetiese induksie (1)
- 9.2 A ✓
Split ring commutator/*Spleetring kommutator* ✓ (2)
- 9.3.1 The *rms* voltage of AC is the DC potential difference which dissipates the same amount of energy as AC. ✓✓
Die wgc spanning van WS is die GS-potensiaalverskil wat dieselfde hoeveelheid energie as WS verbruik. (2)
- 9.3.2
$$V_{\text{rms}} = \frac{V_{\text{max}}}{\sqrt{2}} \quad \checkmark$$
$$220 = \frac{V_{\text{max}}}{\sqrt{2}} \quad \checkmark$$
$$V_{\text{max}} = 311,13 \text{ V} \quad \checkmark$$
 (3)
- 9.3.3 Increase/*Neem toe* ✓ (1)

9.4 Graph of voltage versus time/*Spanning-teenoor-tydgrafiek*

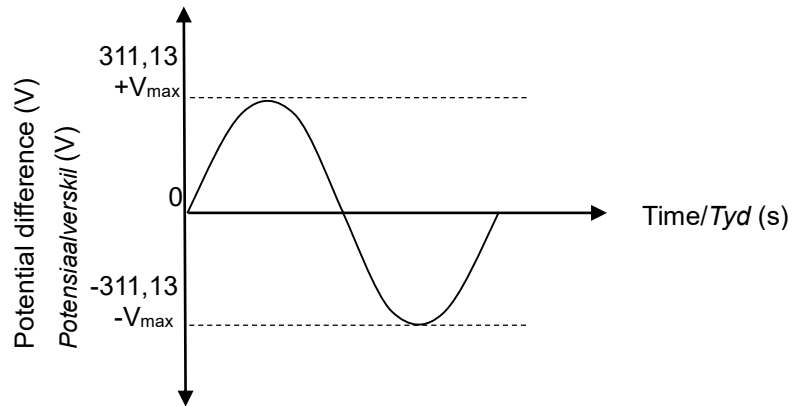

(3)

Marking criteria/Nasienkriteria

| | |
|---|---|
| Shape – sinusoidal curves <i>Vorm – sinusvormige krommes</i> | ✓ |
| Peak value/ <i>Piek waarde</i> | ✓ |
| One cycle/ <i>Een siklus</i> | ✓ |

[12]

TOTAL/TOTAAL: 150