



education

Department:
Education
PROVINCE OF KWAZULU-NATAL

**NATIONAL
SENIOR CERTIFICATE**

GRADE 12

PHYSICAL SCIENCES: PHYSICS (P1)

COMMON TEST

JUNE 2018

MARKS: 100

TIME : 2 hours

This question paper consists of 9 pages and 2 data sheets.

INSTRUCTIONS AND INFORMATION TO CANDIDATES

1. Write your name on the **ANSWER BOOK**.
2. This question paper consists of **SEVEN** questions. Answer **ALL** the questions in the **ANSWER BOOK**.
3. Start **EACH** question on a **NEW** page in the **ANSWER BOOK**.
4. Number the answers correctly according to the numbering system used in this question paper.
5. Leave **ONE** line between two subsections, for example between **QUESTION 2.1** and **QUESTION 2.2**.
6. You may use a non-programmable calculator.
7. You may use appropriate mathematical instruments.
8. You are advised to use the attached **DATA SHEET**.
9. Show **ALL** formulae and substitutions in **ALL** calculations.
10. Round off your final numerical answers to a minimum of **TWO** decimal places.
11. Give brief motivations, discussions, et cetera where required.
12. Write neatly and legibly.

QUESTION 1: MULTIPLE- CHOICE QUESTIONS

Four options are provided as possible answers to the following questions. Each question has only ONE correct answer. Write only the letter (A - D) next to the question number (1.1 – 1.7) in the ANSWER BOOK, for example 1.4 D.

- 1.1 A spaceship experiences a weight of X on earth. It is sent into space and lands on a planet which has a mass twice that of the earth and a radius $\frac{1}{2}$ that of the earth. The weight of the spaceship will be ...

- (A) $8X$
 B $\frac{1}{2}X$
 C X
 D $\frac{1}{4}X$

X

(2)

- 1.2 Two Carts, X and Y, move along a frictionless horizontal track with the same momentum. Cart X has TWICE the mass of Cart Y.

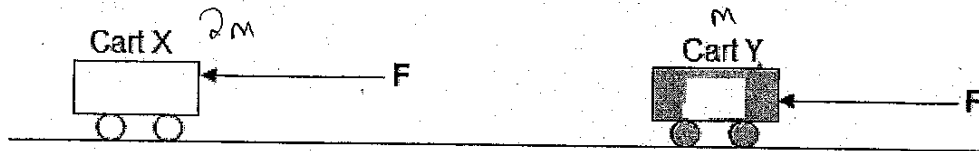

When the horizontal retarding force F is applied simultaneously to both carts, Cart X stops in a time of t seconds.

The time taken for Cart Y to stop will be...

$$p = m \times v$$

- (A) $\frac{1}{2}t$
 B t
 C $2t$
 D $4t$

(2)

- 1.3 An object, moving vertically upwards, reaches a maximum height and falls back to the ground. Ignore air resistance. Which ONE of the following statements is TRUE?

The object experiences an acceleration which

- A is first downwards and then upwards
 B is first upwards and then downwards
 (C) is always downwards.
 D decreases first and then increases

(2)

1.4 The graph shows how the momentum of a motorcycle changes with time.

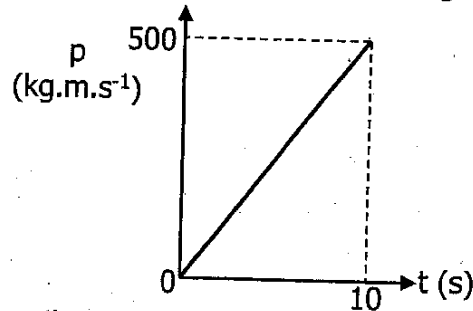

What is the resultant force on the motorcycle?

- A 50 N
- B 500 N
- C 2500 N
- D 5000 N

(2)

1.5 A girl is lifting boxes of identical mass from the ground onto a bench. At first, it takes her 2 s to lift each box. Later in the day it takes her 3 s. Which of the following statements will now be true when she lifts the boxes later in the day?

- A Less work is done in lifting each box.
- B More work is done in lifting each box.
- C Less power is required to lift each box.
- D Greater power is required to lift each box.

(2)

1.6 A girl stands next to the road as a fire engine approaches her with its sirens blaring and the red flashlights on. Which is the correct observation that the girl makes?

	Frequency of sound heard	Colour of flashlight
A	Lower	Red
<input checked="" type="radio"/> B	Higher	Red
C	Lower	Orange
D	Higher	Orange

(2)

1.7 Light reaching the Earth from a galaxy moving away is shifted towards...

- A shorter wavelengths
- B greater velocities
- C higher frequencies
- D longer wavelengths

(2)
[14]

QUESTION 2

Block A (mass 3.5 kg) and Block B (mass 5.5 kg) are connected via a light, inextensible string, X, over a frictionless pulley. Block A is attached to a fixed point by string Y, and is placed on a rough horizontal surface.

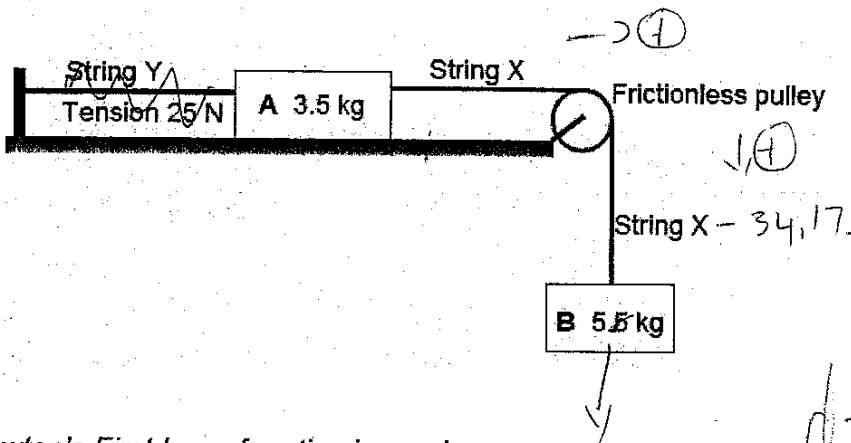

- 2.1 State Newton's First Law of motion in words. (2)
- 2.2 Calculate the magnitude of the tension in string X. (2)
- 2.3 Draw a labelled force diagram to represent the HORIZONTAL forces acting on Block A. (3)
- 2.4 Calculate the magnitude of the frictional force acting between block A and the surface. (3)

String Y is cut and the system starts accelerating. The tension in string X is now 34.17 N.

- 2.5 State Newton's Second Law of motion in words. (2)
- 2.6 Calculate the magnitude of the acceleration of the system. (4)

[16]

$$F_{net} = ma$$

$$(-25N) + (x) = 5,5(0)$$

$$-25N + x = 0$$

$$x = 25N$$

$$\longrightarrow$$

$$F_{net} = ma$$

$$(-25N) + (-ff) = 3,5(0)$$

$$(-25N) + (-ff)$$

$$F_{net} = ma$$

$$x + F_g = 5,5(0)$$

$$x - (5,5 \times 9,8)$$

$$x - 53,9 = 0$$

$$x = 53,9$$

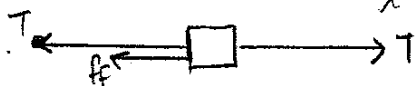

28,9

QUESTION 3

A ball is thrown vertically upwards by a boy standing on top of a building. The ball hits the ground below and bounces vertically upwards.

The graph below shows the motion of the ball.

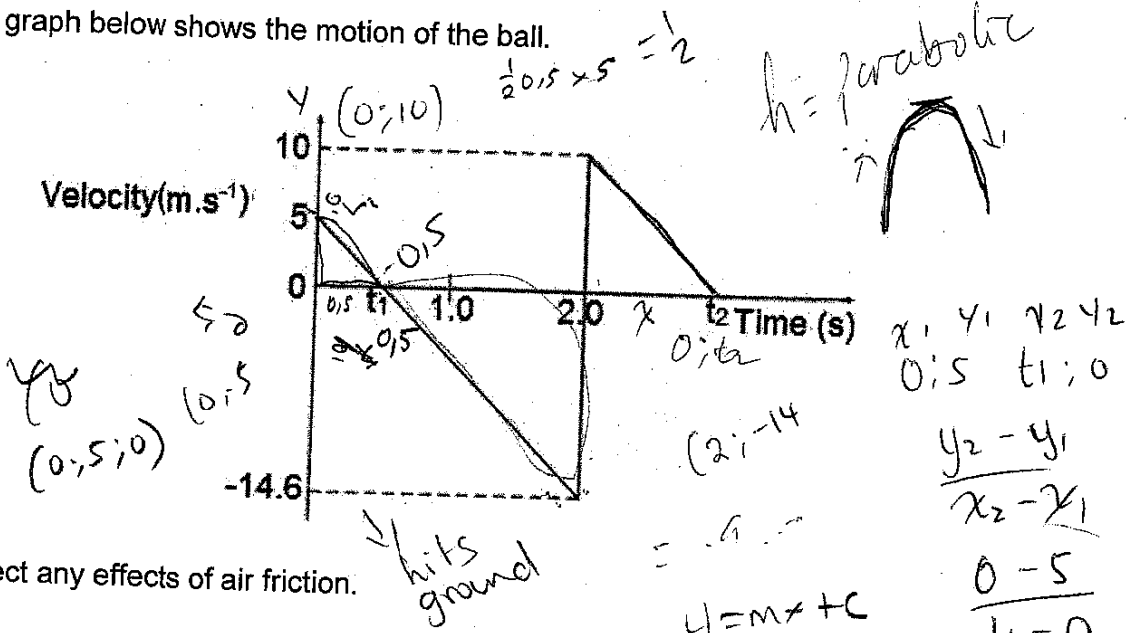

Neglect any effects of air friction.

- 3.1 Define a projectile. (2)
- 3.2 What does t_1 , indicated on the graph, represent? (1)
- 3.3 Determine the value of t_1 . (3)
- 3.4 Calculate the height of the building. = 9.6 (4)
- 3.5 Calculate the value of t_2 . (3)
- 3.6 USE THE GRAPH (i.e. do not use equations of motion) to calculate the distance between the initial position of the ball (i.e. when it leaves the boy's hand) and its maximum height after bouncing. (3)

[16]

$$y = mx + c$$

$$5 = -14.6t_1 + 0$$

$$= 0.5$$

$$v_f = v_i + a \Delta t$$

$$-14.6 = 5 + (-9.8) \Delta t$$

$$\frac{-14.6}{-49} = \frac{-49 \Delta t}{-49}$$

$$= \Delta t$$

w

QUESTION 4

Two boys set up an experiment where they gently push trolley 1 down a gentle slope, and it then collides with a stationary trolley 2.



They want to work out the momentum of the trolleys before and after the collision

- 4.1 Give a reasonable hypothesis for this experiment. (2)
- 4.2 State the definition of *momentum*. (2)

A small car of mass 1 084 kg was travelling east at a speed of $30 \text{ m}\cdot\text{s}^{-1}$. A large SUV of mass 3 437 kg was travelling west at a speed of $25 \text{ m}\cdot\text{s}^{-1}$. The two vehicles collided head on with each other.

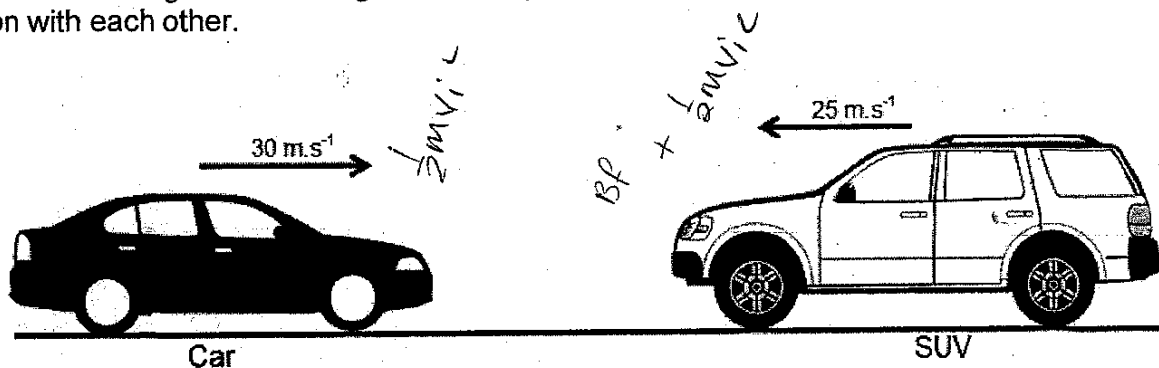

Immediately after the collision, the small car was moving west at $5 \text{ m}\cdot\text{s}^{-1}$.

- 4.3 NAME the law that can be used to calculate the velocity of the SUV immediately after the collision. (1)
- 4.4 Determine the velocity of the SUV immediately after the collision. (5)
- 4.5 Explain what is meant by an *inelastic collision*. (2)
- 4.6 Use calculations to determine if the collision was elastic or not. $E_k \frac{1}{2} m_1 v_1^2 + \frac{1}{2} m_2 v_2^2 = \frac{1}{2} m_1 v_1'^2 + \frac{1}{2} m_2 v_2'^2$ (6)
- 4.7 Both drivers are wearing seat belts. Which driver is likely to be more severely injured on impact? Explain the answer by referring to acceleration and velocity. (3)

$$m_1 \cdot v_{1i} + m_2 \cdot v_{2i} = m_1 \cdot v_{1f} + m_2 \cdot v_{2f}$$

$$a = \frac{\Delta v}{\Delta t} \quad \checkmark \quad a \propto v$$

[21]

QUESTION 5

A weightlifter raises a pack of weights of mass 160 kg through a height of 90 cm. To do this, he exerts a force of 2800 N on the weights.

The effects of air resistance may be ignored.

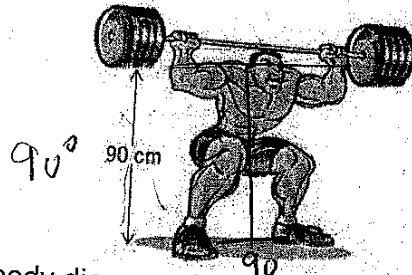

$$E_p = mgh$$

$$= 160 \times 9.8 \times 0,09$$

$$= \underline{141,12 \text{ J}}$$

5.1 Draw a labelled free body diagram showing all forces acting on the weights when they are held 90 cm above the ground. (2)

5.2 Calculate the net work done by the weightlifter on the weights. (4)

QUESTION 6

[6]

The diagram shows part of the roller-coaster at the amusement park. The carriages are pulled from P to Q at a steady speed by an electric motor with a power output of 48 kW. Points Q and R are 68 m and 5 m, respectively, above the ground. At Q the carriages have effectively no kinetic energy and they run freely down to R. The total mass of the carriages is 3 600 kg.

Ignore the effects of air friction.

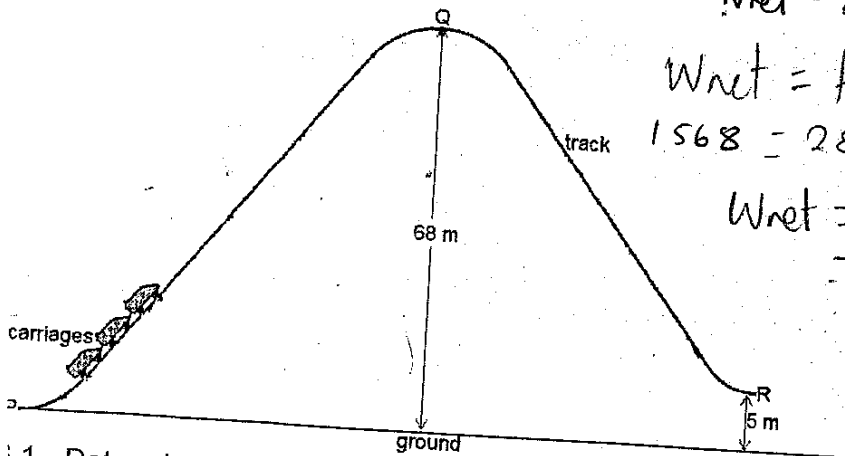

6.2 B

$$W_{net} = 0$$

$$W_{net} = F \cdot d \cdot \cos \theta$$

$$1568 = 2800 \text{ N} \cdot 0,09$$

$$W_{net} = E_p + 2800 \text{ N}$$

$$= 141,12 + 2800 \cdot 1/2 = 1/2 mv^2$$

$$E_k + E_p$$

1.1 Determine the total mechanical energy of the carriages at point Q. (3)

2 State the definition of power. (2)

3 Calculate the time taken for the carriages to move from P to Q. (3)

4 State the principle of conservation of mechanical energy in words. (2)

5 Calculate the speed of the carriages on reaching point R. (4)

[14]

QUESTION 7

$$v = 0$$

$$v_c = ?$$

A stationary source emits a sound wave of frequency 5000 Hz. An object approaches to this source with an unknown velocity. The sound wave is reflected from the moving object, which is then detected by the source.

Take the speed of sound in air as 340 m.s^{-1} .

- 7.1 State the definition of the *Doppler Effect*. (2)
- 7.2 Calculate the wavelength of the waves being generated by the source. (3)
- 7.3 Calculate the velocity of the object if the detected wave, by the source, has a frequency of 5104 Hz. (6)
- 7.4 State TWO applications of the Doppler Effect in Medical Science. (2)

TOTAL: [13]
100

3.3 use gradient
use $v_f = v_i + a \Delta t$

0,5 s

1 2 3 4 5 6 7 8 9 10 11 12 13 14 15 16 17 18 19 20 21 22 23 24 25 26 27 28 29 30 31 32 33 34 35 36 37 38 39 40 41 42 43 44 45 46 47 48 49 50 51 52 53 54 55 56 57 58 59 60 61 62 63 64 65 66 67 68 69 70 71 72 73 74 75 76 77 78 79 80 81 82 83 84 85 86 87 88 89 90 91 92 93 94 95 96 97 98 99 100





education

Department: Education
PROVINCE OF KWAZULU-NATAL

PHYSICAL SCIENCES P1

MARKING GUIDELINE

COMMON TEST

JUNE 2018

NATIONAL SENIOR CERTIFICATE

GRADE 12

This marking guideline consists of 6 pages.

QUESTION 1

- 1.1 A✓✓
- 1.2 B✓✓
- 1.3 C✓✓
- 1.4 A✓✓
- 1.5 C✓✓
- 1.6 B✓✓
- 1.7 D✓✓

7x2 = [14]

QUESTION 2

2.1 An object continues in a state of rest or uniform velocity unless it is acted upon by a net or resultant force. ✓✓ (2)

2.2 $T_x = mg$
 $= (5.5)(9.8) ✓$
 $= 53.90 \text{ N} ✓$

2.3



Accepted Labels

- T_x : Tension X ✓
- T_y : Tension Y ✓
- F_f / $f_{s,max}$: Friction ✓

2.4 POSITIVE MARKING FROM QUESTION 2.3

$T_y + T_x + F_f = 0 ✓$
 $-25 + 53.9 + F_f = 0 ✓$
 $F_f = -28,90$
 $F_f = 28,90 \text{ N} ✓$

(3)

(3)

2.5 When a resultant/net force acts on an object, the object will accelerate in the direction of the force at an acceleration directly proportional to the force and inversely proportional to the mass of the object. ✓✓ (2)

OR

The resultant/net force acting on an object is equal to the rate of change of momentum of the object in the direction of the resultant/net force. ✓✓

2.6 $F_{\text{net}} = ma \checkmark$

$$mg + (-Tx) = ma$$

$$(5.5)(9.8) \checkmark - 34.17 \checkmark = 5.5a$$

$$a = 3.59 \text{ m.s}^{-2} \checkmark$$

(4) [16]

QUESTION 33.1 An object upon which the only force acting is the force of gravity. $\checkmark \checkmark$

(2)

3.2 Time taken by the ball to reach the maximum height. \checkmark

(1)

3.3

Upward is positive

$$v_f = v_i + a \Delta t \checkmark$$

$$0 = 5 + (-9.8) \Delta t \checkmark$$

$$t = 0.51 \text{ s} \checkmark$$

Downward is positive

$$v_f = v_i + a \Delta t \checkmark$$

$$0 = -5 + 9.8 \Delta t \checkmark$$

$$t = 0.51 \text{ s} \checkmark$$

(3)

3.4 **OPTION 1****Upward is positive**

$$v_f^2 = v_i^2 + 2a\Delta y \checkmark$$

$$(-14.6)^2 \checkmark = 5^2 + 2(-9.8) \Delta y \checkmark$$

$$\Delta y = -9.6$$

$$\text{height} = 9.6 \text{ m} \checkmark$$

Downward is positive

$$v_f^2 = v_i^2 + 2a\Delta y \checkmark$$

$$(14.6)^2 \checkmark = (-5)^2 + 2(9.8) \Delta y \checkmark$$

$$\Delta y = 9.6 \text{ m}$$

$$\text{height} = 9.6 \text{ m} \checkmark$$

(4)

OPTION 2 POSITIVE MARKING FROM QUESTION 3.3

$$\Delta y = \text{area of triangle 1} + \text{area of triangle 2} \checkmark$$

$$= \frac{1}{2}(0.51)(5) \checkmark + \frac{1}{2}(2-0.51)(-14.6) \checkmark$$

$$= -9.60$$

$$\text{height} = 9.60 \text{ m} \checkmark$$

(4)

OPTION 3 $\Delta y = \text{area of a trapezium}$

$$= \frac{1}{2}(\text{sum of parallel sides}) \times (\text{perpendicular distance}) \checkmark$$

$$= \frac{1}{2}(-5-14.6) \checkmark \times (2-1.02) \checkmark$$

$$= -9.60$$

$$\text{height} = 9.60 \text{ m} \checkmark$$

(4)

3.5 **OPTION 1****Upward is positive**

$$v_f = v_i + a \Delta t \checkmark$$

$$0 = 10 + (-9.8) \Delta t \checkmark$$

$$\Delta t = 1.02 \text{ s} \checkmark$$

Downward is positive

$$v_f = v_i + a \Delta t \checkmark$$

$$0 = -10 + (9.8) \Delta t \checkmark$$

$$\Delta t = 1.02 \text{ s} \checkmark$$

(3)

OPTION 2

$$\text{slope} = \frac{\Delta y}{\Delta t}$$

$$-9.8 = \frac{0-10}{\Delta t}$$

$$\Delta t = 1.02 \text{ s}$$

(3)

3.6 **OPTION 1**

distance = area of triangle 1 + area of triangle 2 + area of triangle 3

$$= \frac{1}{2}(0.51)(5) + \frac{1}{2}(2-0.51)(-14.6) \checkmark + \frac{1}{2}(2+1.02)(10) \checkmark$$

$$= -4.50$$

$$\text{distance} = 4.50 \text{ m} \checkmark$$

(4)

OPTION 2

distance = area of a trapezium + area of triangle

$$= \frac{1}{2}(-5-14.6) \times (2-1.02) \checkmark + \frac{1}{2}(1.02)(10) \checkmark$$

$$= -9.604 + 5.10$$

$$= -4.504$$

$$\text{distance} = 4.50 \text{ m} \checkmark$$

(3) [16]

QUESTION 44.1 Total momentum of the trolleys before collision will equal total momentum after collision because momentum should be conserved in an isolated system. $\checkmark \checkmark$

(2)

4.2 The product of mass and velocity of on object. $\checkmark \checkmark$

(2)

4.3 Law of conservation of (linear) momentum. \checkmark

(1)

4.4

total Pbefore = total Pafter \checkmark

$$(1084)(30) + (3437)(-25) \checkmark = (1084)(-5) + 3437v_f \checkmark$$

$$v_f = -13.96$$

$$v_f = 13.96 \text{ m.s}^{-1} \checkmark \text{ (west)} \checkmark$$

(5)

4.5

total Kbefore = $\frac{1}{2}mv_1^2 + \frac{1}{2}mv_2^2 \checkmark$

$$= \frac{1}{2}(1084)(30)^2 + \frac{1}{2}(3437)(-25)^2 \checkmark$$

$$= 1.56 \times 10^6 \text{ J} \checkmark$$

total Kafter = $\frac{1}{2}mv_1^2 + \frac{1}{2}mv_2^2$

$$= \frac{1}{2}(1084)(-5)^2 + \frac{1}{2}(3437)(-13.96)^2 \checkmark$$

$$= 3.48 \times 10^5 \text{ J} \checkmark$$

Inelastic collision \checkmark

(6)

- 4.6 Small car driver ✓
(small car-driver system) has greater acceleration ✓
(small car-driver system) has greater change in velocity ✓

(3)
[21]

QUESTION 5

5.1



Accepted Labels

F_{applied} : Applied force ✓
F_g : weight ✓

5.2 $W_{net} = F_{net}\Delta x \cos\theta$ ✓
 $= F_{applied}\Delta x \cos\theta + F_g\Delta x \cos\theta$ ✓
 $= (2800)(0.9)\cos 0^\circ + (160)(9.8)(0.9)\cos 180^\circ$ ✓
 $= 1108.80 \text{ J}$ ✓

(2)

(4)
[6]

QUESTION 6

6.1 $E_M = K + U$ ✓
 $= \frac{1}{2}mv^2 + mgh$ ✓
 $= 0 + (3600)(9.8)(68)$ ✓
 $= 2.40 \times 10^6 \text{ J}$ ✓

(3)

- 6.2 Power is the rate at which work is done or energy is expended. ✓✓

(2)

6.3 $P = \frac{W}{\Delta t}$ ✓
 $48000 = \frac{2399040}{\Delta t}$ ✓
 $\Delta t = 49.98 \text{ s}$ ✓

(3)

6.4 $(K + U)_c = (K + U)_R$ ✓
 $0 + 2399040 = \frac{1}{2}(3600)v^2 + (3600)(9.8)(5)$ ✓
 $v = 35.14 \text{ m.s}^{-1}$ ✓

(4)
[12]

14

QUESTION 7

- 7.1 Apparent change in frequency (or pitch) of the sound detected by a listener because the sound source and the listener have different velocities relative to the medium of sound propagation. ✓✓

(2)

OR

Apparent change in the observed frequency of a sound wave when the source of the sound is moving relative to the listener. ✓✓

(2)

7.2 $v = f\lambda$ ✓
 $340 = 5000\lambda$ ✓
 $\lambda = 0.068 \text{ m}$ ✓

(3)

7.3 $f_l = \frac{v \pm v_l}{v \pm v_s} f_s$ ✓

Shift 1: $f_l = \frac{340 + v_o}{340} (5000)$ ✓

Shift 2: $f_l = \frac{340}{340 - v_o} f_s$ ✓

$5104 = \left(\frac{340}{340 - v_o} \right) \times \frac{340 + v_o}{340} (5000)$ ✓

(6)

$v_o = 3.50 \text{ m.s}^{-1}$, towards the source ✓

- 7.4 To measure heartbeat of the unborn foetus in the womb. ✓
 To measure blood flow rate. ✓

(2)

[13]

TOTAL: 100

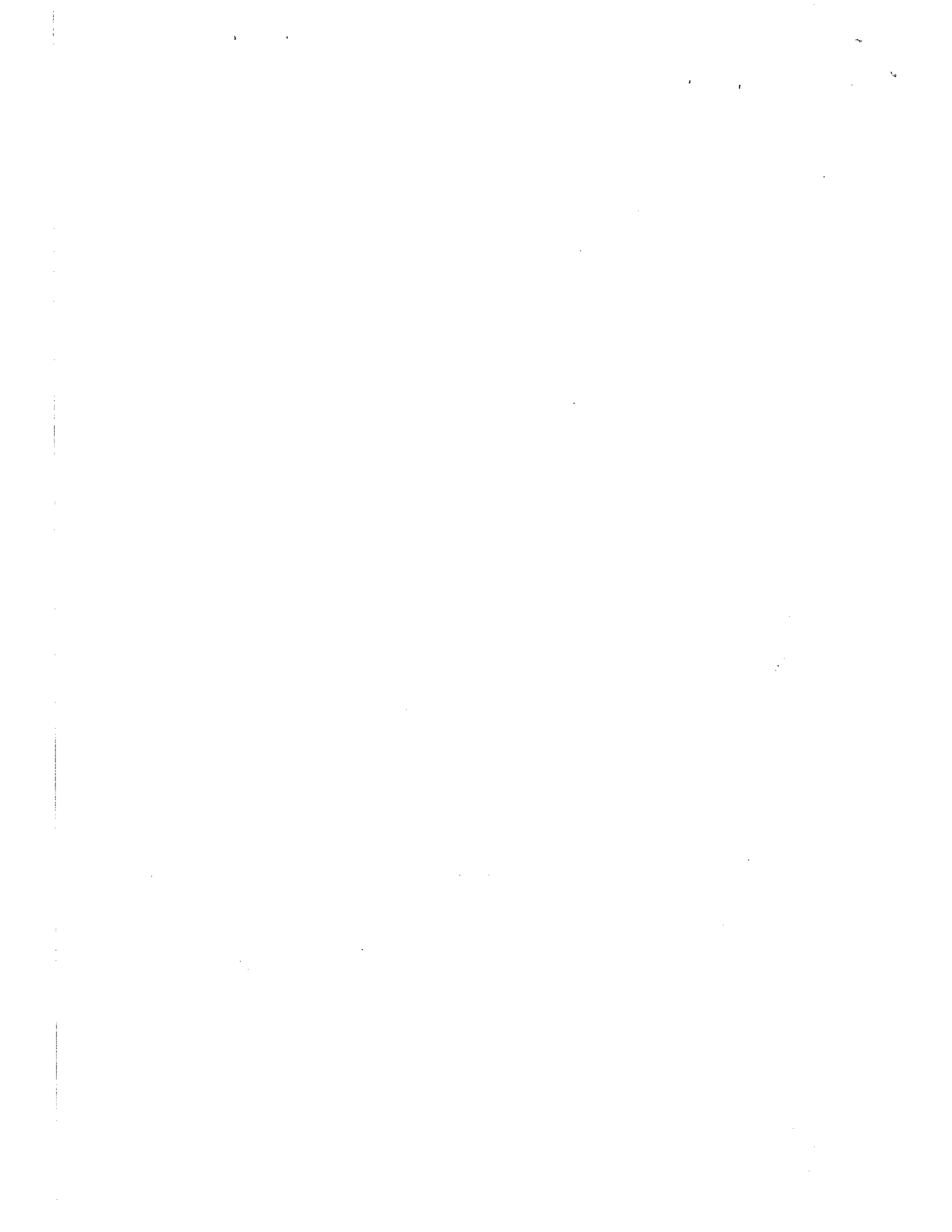



education

Department:
Education
PROVINCE OF KWAZULU-NATAL

**NATIONAL
SENIOR CERTIFICATE**

GRADE 12

PHYSICAL SCIENCES P2 (CHEMISTRY)

COMMON TEST

JUNE 2018

MARKS: 100

TIME: 2 Hours

This question paper consists of 11 pages and 2 data sheets.

INSTRUCTIONS AND INFORMATION TO CANDIDATES

1. Write your name and other information in the appropriate spaces on the ANSWER BOOK.
2. The question paper consists of SEVEN questions. Answer ALL the questions in the ANSWER BOOK.
3. Start EACH question on a NEW page in the ANSWER BOOK.
4. Number the answers correctly according to the numbering system used in this question paper.
5. Leave one line between two sub-questions, for example between QUESTION 2.1 and QUESTION 2.2.
6. You may use a non-programmable pocket calculator.
7. You may use appropriate mathematical instruments.
8. You are advised to use the attached DATA SHEETS.
9. Show ALL formulae and substitutions in ALL calculations.
10. Round off your final numerical answers to a minimum of TWO decimal places where applicable.
11. Give brief motivations, discussions, et cetera where required.
12. Write neatly and legibly.

QUESTION 1: MULTIPLE – CHOICE QUESTIONS

Various options are provided as possible answers to the following questions. Choose the answer and write only the letter (A-D) next to the question number (1.1 – 1.7) in the ANSWER BOOK, for example 1.8 D.

1.1 Which one of the following organic compounds is a tertiary alcohol?

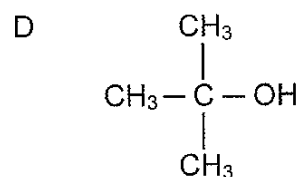
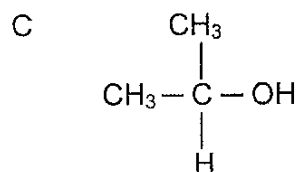
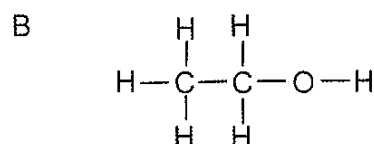
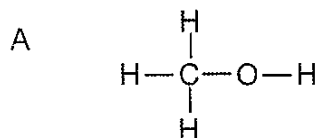

(2)

1.2 The melting points of four hydrocarbons that are chain isomers are shown in the table below:

Hydrocarbon	Melting Point (°C)
P	28
Q	-56,5
R	-95
S	-182,5

The hydrocarbon with the longest chain is . . .

- A P
B Q
C R
D S

(2)

1.3 A polymer that is the product of a condensation polymerisation reaction is, . . .

- A polyactic acid
 - B polypropylene
 - C polyvinyl chloride
 - D polytetrafluoroethene
- (2)

1.4 The reaction below reaches equilibrium at 900 °C.



The Kc expression at 900 °C is equal to . . .

- A $\frac{[\text{CaCO}_3][\text{CaO}]}{[\text{CO}_2]}$
 - B $\frac{[\text{CO}_2]}{[\text{CaCO}_3][\text{CaO}]}$
 - C $[\text{CO}_2]$
 - D $[\text{CaCO}_3][\text{CaO}]$
- (2)

1.5 The rate of a chemical reaction can be expressed in . . .

- A moles of product formed per litre of solution.
 - B volume of gas formed per unit time.
 - C energy consumed per mole.
 - D grams per mole.
- (2)

1.6 The equation below represents a chemical reaction at equilibrium in a closed container:

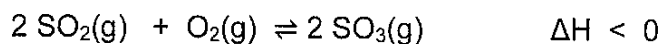

The yield of $\text{SO}_3(\text{g})$ can be increased by . . .

- A removing some of the $\text{O}_2(\text{g})$ from the reaction.
 - B removing some of the $\text{SO}_2(\text{g})$ from the reaction.
 - C increasing the temperature at which the reaction occurs.
 - D decreasing the temperature at which the reaction occurs.
- (2)

1.7 Which one of the following aqueous solutions is a WEAK base?

- A $0,5 \text{ mol} \cdot \text{dm}^{-3} \text{ HCl}$
 - B $0,5 \text{ mol} \cdot \text{dm}^{-3} \text{ NaOH}$
 - C $0,5 \text{ mol} \cdot \text{dm}^{-3} \text{ Na}_2\text{CO}_3$
 - D $0,5 \text{ mol} \cdot \text{dm}^{-3} \text{ CH}_3\text{COOH}$
- (2)

[14]

QUESTION 2 (Start on a new page.)

The letters A to E in the table below represent five organic compounds.

A	$\begin{array}{ccccccc} & \text{H} & & \text{H} & & \text{H} & & \text{O} & & & \\ & & & & & & & & & & \\ \text{H} & - \text{C} & - & \text{C} & - & \text{C} & - & \text{C} & - & \text{H} & \\ & & & & & & & & & & \\ & \text{H} & & \text{H} & & \text{H} & & & & & \end{array}$	B	$\begin{array}{ccccccc} & \text{H} & & \text{H} & & \text{O} & & \text{H} & & & \\ & & & & & & & & & & \\ \text{H} & - \text{C} & - & \text{C} & - & \text{C} & - & \text{C} & - & \text{H} & \\ & & & & & & & & & & \\ & \text{H} & & \text{H} & & & & \text{H} & & & \end{array}$
C	$\text{CH}_3\text{CH}(\text{CH}_3)\text{CH}_2\text{CH}(\text{CH}_3)\text{CH}_2\text{CH}_3$	D	$\begin{array}{ccccccc} & \text{H} & & & & \text{H} & & & & & \\ & & & & & & & & & & \\ \text{H} & - \text{C} & - & \text{C} \equiv \text{C} & - & \text{C} & - & \text{CH}_3 & & & \\ & & & & & & & & & & \\ & \text{H} & & & & \text{CH}_3 & & & & & \end{array}$
E	Ethene		

2.1 Write down the LETTER that represents EACH of the following:

2.1.1 An isomer of 4-methylheptane (1)

2.1.2 A ketone (1)

2.2 For compound D, write down:

2.2.1 It's IUPAC name. (2)

2.2.2 The general formula of the homologous series to which it belongs. (1)

2.3 Write down the structural formula of the polymer of compound E. (1)

[6]

QUESTION 3 (Start on a new page.)

M and N are TWO straight chain organic compounds that belong to different homologous series.

3.1 Explain what is meant by the underlined phrase in the above statement. (1)

Both M and N have the molecular formula, $C_3H_6O_2$.

3.2 Name the type of isomer that compounds M and N represent.
(Choose from CHAIN, POSITIONAL or FUNCTIONAL isomer) (1)

3.3 Compound M has a higher vapour pressure than compound N.

3.3.1 Define vapour pressure. (2)

3.3.2 Explain in terms of intermolecular forces and energy the difference in the vapour pressure of compound M and compound N. (3)

3.3.3 Which compound, M or N has a higher boiling point? Give a reason for the answer. (2)

3.3.4 Write down the IUPAC name and structural formula of compound N. (3)

[12]

QUESTION 4 (Start on a new page.)

In the flow diagram below, A, B, C, D, E and F represent organic reactions. **P** and **Q** represent organic compounds.

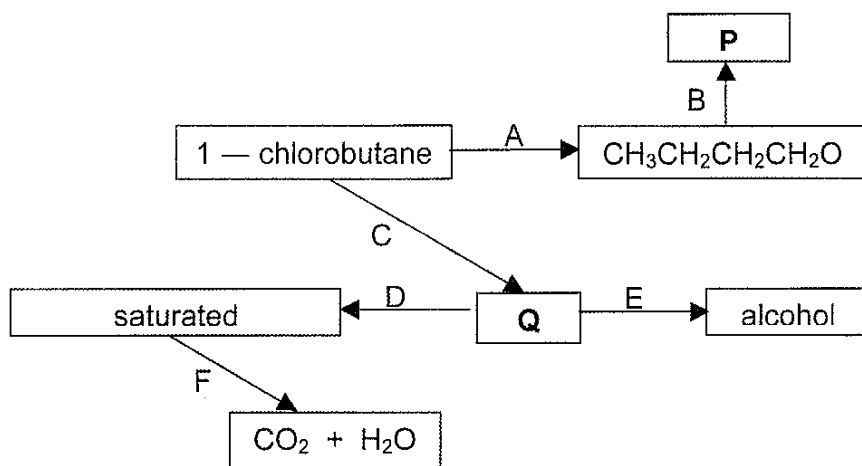

Reaction C represents a dehydrohalogenation reaction.

- 4.1 Name the type of reaction represented by:
- 4.1.1 A (1)
- 4.1.2 D (1)
- 4.1.3 F (1)
- 4.2 Give a reason why the hydrocarbon produced by reaction D is described as saturated. (1)
- 4.3 Write down the name or formula of the catalyst needed for reaction D. (1)
- 4.4 Reaction B is carried out in a water bath to produce a pleasant smelling organic compound, P, with the molecular formula $C_7H_{14}O_2$.
- 4.4.1 Give a reason why reaction B is carried out in water bath instead of direct heating over a flame. (1)
- 4.4.2 Draw the structural formulae for compound P. (3)
- 4.5 State the conditions that must be satisfied for reaction C. (2)
- 4.6 The alcohol produced by reaction E is a positional isomer of the alcohol produced by reaction A.
- 4.6.1 Write down the structural formula for compound Q. (2)
- 4.6.2 Give the IUPAC name of the alcohol produced by reaction E. (2)
- 4.7 Write a balanced equation, using molecular formulae to show the reaction that takes place when reaction F takes place in excess oxygen. (3)

[18]

QUESTION 5 (Start on a new page)

- 5.1 The Maxwell-Boltzmann curve labelled L, below, represents the number of particles against kinetic energy for a hypothetical reaction:

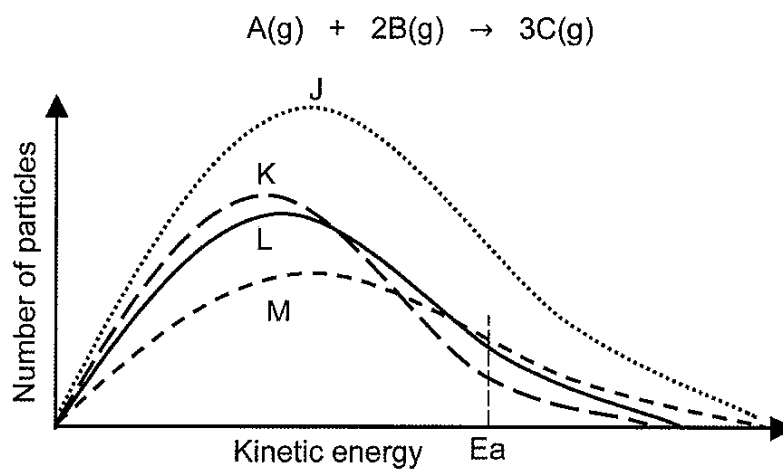

J, K and M represent the curves obtained when the reaction conditions are changed for the hypothetical reaction.

- 5.1.1 Identify the reaction condition that was changed to obtain curve J. (1)
- 5.1.2 Explain how the change identified in question 5.1.1 affects the rate of the reaction. (3)
- 5.1.3 State the change that was made to the reaction conditions to obtain curve K. (1)

- 5.2 Learners use copper(II)oxide(CuO) powder to decompose hydrogen peroxide, during a class experiment. They add 1 g copper(II)oxide to 100 cm³ hydrogen peroxide in a flask connected to a delivery tube. The reaction that takes place is represented by the following balanced equation.

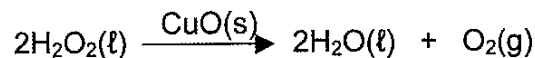

The volume of oxygen produced is measured every 10 seconds. The results obtained are shown in the sketch graph below:

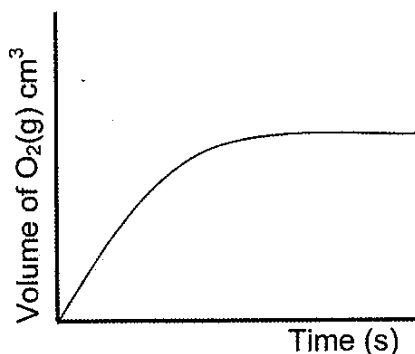

- 5.2.1 What happens to the gradient of the above graph as the reaction proceeds. (Choose from INCREASES, DECREASES or REMAINS THE SAME) (1)

- 5.2.2 Give a reason for the answer to question 5.2.1. (1)

The learners repeat the above experiment but this time forget to add the copper(II)oxide powder. They notice that the volume of oxygen gas produced per second decreases.

- 5.2.3 Copy the above graph in your answer book and label it A. On the same system of axes sketch a graph to show the results that will be obtained. Label this graph B. (3)

- 5.2.4 Explain fully why the volume of oxygen gas produced per second decreases. (4)
[14]

QUESTION 6 (Start on a new page)

Sulphur dioxide gas reacts with an unknown quantity of oxygen gas in a sealed 2 dm³ container at a temperature T °C, according to the following balanced equation:

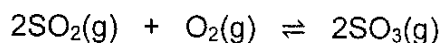

The equilibrium constant K_c for this reaction at T °C is 160.

The graph below, not drawn to scale, shows how the mass of SO₂(g) present in the container changes with time at T °C.

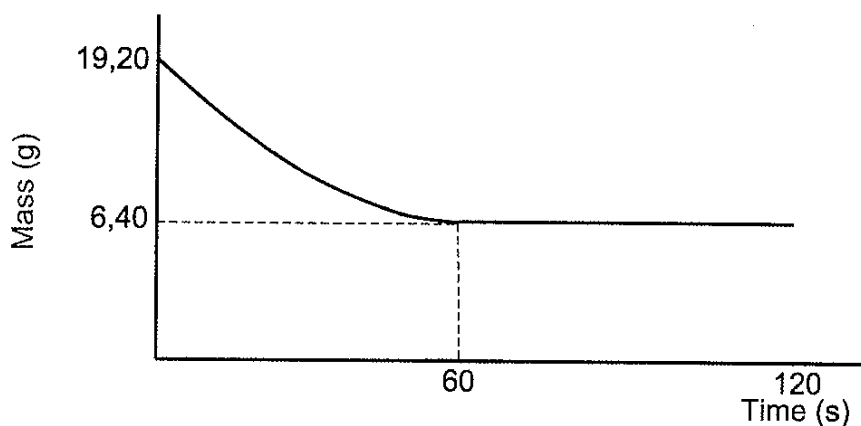

The reaction between the gases sulphur dioxide and oxygen reaches equilibrium after 60 s.

- 6.1 Why is the reaction said to be in equilibrium after 60 s? (2)
- 6.2 Calculate the initial number of moles of O₂(g) that was present in the container. (8)
- 6.3 The temperature is NOW increased. The K_c value decreases.
- 6.3.1 State Le Chatelier's Principle. (2)
- 6.3.2 Is the reaction between sulphur dioxide and oxygen endothermic or exothermic? Explain the answer. (4)

[16]

QUESTION 7 (Start on a new page.)

7.1 A learner dissolves sodium acetate crystals in water and measures the pH of the solution.

7.1.1 Define the term *hydrolysis of a salt*. (2)

7.1.2 Will the pH of the solution be GREATER THAN, SMALLER THAN or EQUAL TO 7? (1)

7.1.3 Write a relevant balanced equation to support the answer to question 7.1.2. (3)

7.2 Hydrochloric acid is a strong monoprotic acid.

7.2.1 Define an acid in terms of the Lowry Brønsted theory. (2)

7.2.2 Give a reason why hydrochloric acid is referred to as a monoprotic acid. (1)

7.3 In a titration to determine the concentration of undiluted hydrochloric acid, a standard solution of a strong base, barium hydroxide of concentration $0,1 \text{ mol}\cdot\text{dm}^{-3}$ is used. 10 cm^3 of the hydrochloric acid is diluted with 40 cm^3 water to a volume of 50 cm^3 .

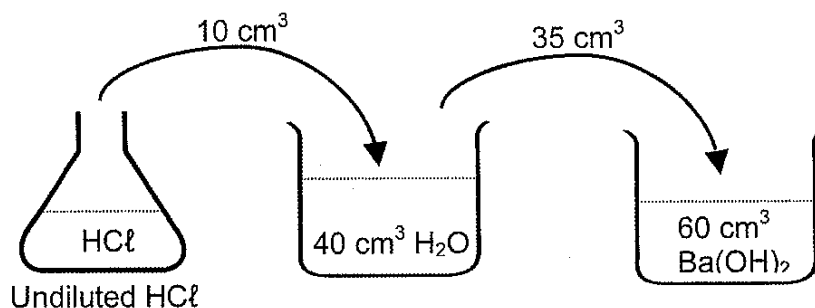

60 cm^3 of the barium hydroxide solution neutralizes exactly 35 cm^3 of the diluted hydrochloric acid solution.

7.3.1 The following indicators are available for the titration:

INDICATOR	pH range
P	3,10 – 4,40
Q	6,60 – 7,60
R	8,30 – 10,00

Which ONE of the above indicators (P, Q or R) is most suitable to indicate the exact endpoint in this titration? Give a reason for the answer. (2)

7.3.2 Calculate the concentration of the undiluted hydrochloric acid.
The balanced equation for the reaction is:

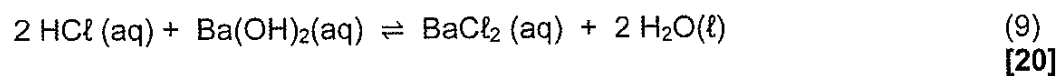

(9)
[20]

TOTAL MARKS: 100

**DATA FOR PHYSICAL SCIENCES GRADE 12
PAPER 2 (CHEMISTRY)**

**GEGEWENS VIR FISIESTE WETENSAPPE GRAAD 12
VRAESTEL 2 (CHEMIE)**

TABLE 1: PHYSICAL CONSTANTS/TABEL 1: FISIESTE KONSTANTES

NAME/NAAM	SYMBOL/SIMBOOL	VALUE/WAARDE
Standard pressure <i>Standaarddruk</i>	p^θ	$1,013 \times 10^5 \text{ Pa}$
Molar gas volume at STP <i>Molêre gasvolume by STD</i>	V_m	$22,4 \text{ dm}^3 \cdot \text{mol}^{-1}$
Standard temperature <i>Standaardtemperatuur</i>	T^θ	273 K
Charge on electron <i>Lading op elektron</i>	e	$-1,6 \times 10^{-19} \text{ C}$
Avogadro's constant <i>Avogadro-konstante</i>	N_A	$6,02 \times 10^{23} \text{ mol}^{-1}$

TABLE 2: FORMULAE/TABEL 2: FORMULES

$n = \frac{m}{M}$	$n = \frac{N}{N_A}$
$c = \frac{n}{V}$ or/of $c = \frac{m}{MV}$	$n = \frac{V}{V_m}$
$\frac{c_a V_a}{c_b V_b} = \frac{n_a}{n_b}$	$\text{pH} = -\log[\text{H}_3\text{O}^+]$
$K_w = [\text{H}_3\text{O}^+][\text{OH}^-] = 1 \times 10^{-14}$ at/by 298 K	
$E_{\text{cell}}^\theta = E_{\text{cathode}}^\theta - E_{\text{anode}}^\theta$ / $E_{\text{sel}}^\theta = E_{\text{katode}}^\theta - E_{\text{anode}}^\theta$	
or/of $E_{\text{cell}}^\theta = E_{\text{reduction}}^\theta - E_{\text{oxidation}}^\theta$ / $E_{\text{sel}}^\theta = E_{\text{reduksie}}^\theta - E_{\text{oksidasie}}^\theta$	
or/of $E_{\text{cell}}^\theta = E_{\text{oxidising agent}}^\theta - E_{\text{reducing agent}}^\theta$ / $E_{\text{sel}}^\theta = E_{\text{oksideermiddel}}^\theta - E_{\text{reduseermiddel}}^\theta$	

TABLE 3: THE PERIODIC TABLE OF ELEMENTS
TABEL 3: DIE PERIODIEKE TABEL VAN ELEMENTE

	(i)	(ii)	3	4	5	6	7	8	9	10	11	12	13	14	15	16	17	18
	1	2											(iii)	(iv)	(v)	(vi)	(vii)	(viii)
	H	He											B	C	N	O	F	Ne
1,1	1	4											11	12	14	16	19	20
0,1	Li	Be											13	14	15	16	17	18
7	7	9											Al	Si	P	S	Cl	Ar
23	23	24											27	28	31	32	35,5	40
19	19	20	21	22	23	24	25	26	27	28	29	30	31	32	33	34	35	36
39	39	40	45	48	51	52	55	56	59	59	63,5	65	70	73	75	79	80	84
37	37	38	39	40	41	42	43	44	45	46	47	48	49	50	51	52	53	54
85	85	88	89	91	92	96	96	101	103	106	108	112	115	119	122	128	127	131
86	86	88	89	91	92	96	96	101	103	106	108	112	115	119	122	128	127	131
87	87	88	89	91	92	96	96	101	103	106	108	112	115	119	122	128	127	131
133	133	137	139	179	181	184	186	190	192	195	197	201	204	207	209			
87	87	88	89	179	181	184	186	190	192	195	197	201	204	207	209			
Fr	Fr	Ra	Ac										Tl	Pb	Bi	Po	At	Rn
87	87	88	89	179	181	184	186	190	192	195	197	201	204	207	209			
140	140	141	144	144	144	144	144	144	144	144	144	144	144	144	144	144	144	144
90	90	91	92	92	92	92	92	92	92	92	92	92	92	92	92	92	92	92
Th	Th	Pa	U	Np	Pu	Am	Cm	Bk	Cf	Es	Fm	Md	No	Lr				
232	232	238	238	238	238	238	238	238	238	238	238	238	238	238	238	238	238	238
Ce	Ce	Pr	Nd	Pm	Sm	Eu	Gd	Tb	Dy	Ho	Er	Tm	Yb	Lu				
140	140	141	144	144	150	152	157	159	163	165	167	169	173	175				
90	90	91	92	93	94	95	96	97	98	99	100	101	102	103				
Th	Th	Pa	U	Np	Pu	Am	Cm	Bk	Cf	Es	Fm	Md	No	Lr				
232	232	238	238	238	238	238	238	238	238	238	238	238	238	238				

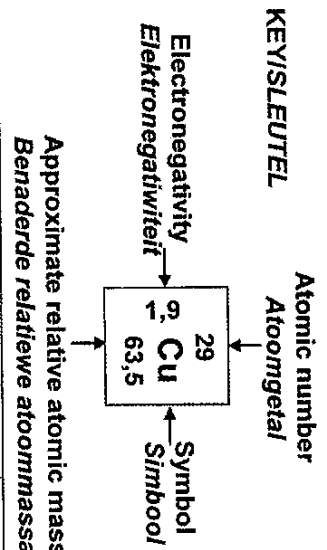

Grades 12, 11, 10 /



education

Department
Education
PROVINCE OF KWAZULU-NATAL

PHYSICAL SCIENCES P2 (CHEMISTRY)

MARKING GUIDELINE

COMMON TEST

JUNE 2018

**NATIONAL
SENIOR CERTIFICATE**

GRADE 12

MARKS: 100

TIME: 2 hours

This marking guideline consists of 7 pages.

The marking guidelines as per 2014 Examination Guidelines, pages 34 – 37 must be applied when marking this Paper.

Copyright Reserved

Please Turn Over

Physical Sciences P2

NSC – Marking Guideline

June 2018 Common Test

QUESTION 1

- 1.1 D ✓✓ (2)
- 1.2 A ✓✓ (2)
- 1.3 A ✓✓ (2)
- 1.4 C ✓✓ (2)
- 1.5 B ✓✓ (2)
- 1.6 D ✓✓ (2)
- 1.7 C ✓✓ (2) [14]

QUESTION 2

- 2.1 2.1.1 C ✓ (1)
- 2.1.2 B ✓ (1)
- 2.2 2.2.1 4-methylpent-2-yne ✓ (2)
- 2.2.2 C_nH_{2n-2} ✓ (1)

2.3

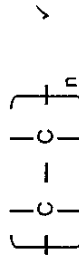

(1)
[6]

Please Turn Over

QUESTION 3

- 3.1 They have different functional groups ✓ (1)
- 3.2 functional ✓ (1)
- 3.3 Pressure exerted by a vapour at equilibrium with its liquid in a closed system. ✓✓ (2)

3.3.2 The intermolecular forces between molecules of M are weaker than the intermolecular forces of N ✓
They will require less energy to overcome ✓
M has a higher vapour pressure ✓

OR

The intermolecular forces between molecules of N are stronger than the intermolecular forces of M ✓
They will require more energy to overcome ✓
N has a lower vapour pressure ✓

3.3.3 N ✓ has a lower vapour pressure ✓ (3)

3.3.4 N ✓ has a lower vapour pressure ✓ (2)

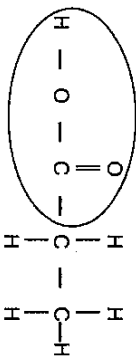

- Whole structure correct: 2/2
- Only functional group correct: 1/2
- More than one functional group: 0/2
- propanoic acid ✓

(3)
[12]

QUESTION 4

- 4.1 substitution/hydrolysis ✓ (1)
- 4.1.1 addition/hydrogenation ✓ (1)
- 4.1.3 combustion ✓ (1)

4.2 contains only single bonds between atoms of carbon/no multiple bonds between atoms of carbon ✓ (1)

4.3 Pt/platinum ✓ (1)

4.4 4.4.1 alcohol is flammable/burns easily ✓ (1)

4.4.2

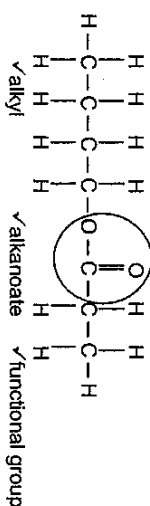

(3)

4.5 (Strongly) heat the haloalkane under reflux ✓
With a concentrated solution of sodium hydroxide/potassium hydroxide in ethanol ✓ (2)

4.6 4.6.1

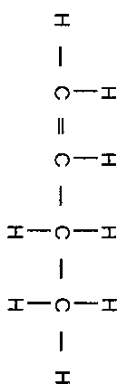

- ✓ double bond between first and second carbon
- ✓ 4 carbon atoms

(2)

4.6.2 butan-2-ol ✓ (2)

4.7 $2C_4H_{10} + 13O_2 \rightarrow 8CO_2 + 10H_2O$ ✓LHS ✓RHS ✓BAL (3)
[18]

QUESTION 5

- 5.1 concentration ✓ (1)
- 5.1.1 concentration ✓ (1)
- 5.1.2 an increase in concentration increases the number of reacting molecules ✓
number of effective collision that occur per unit time increases ✓ (3)
- 5.1.3 temperature decreases ✓ (1)
- 5.2 decreases ✓ (1)
- 5.2.1 decreases ✓ (1)
- 5.2.2 reaction rate decreases ✓ (1)

5.2.3

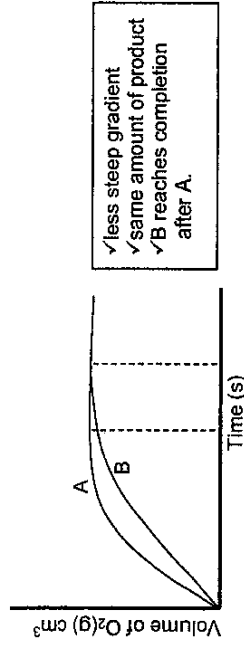

- 5.2.4 CuO is a catalyst ✓
Removal of the catalyst increases the activation energy ✓
Fewer particles have sufficient energy. ✓
Number of effective collisions that occur per unit time decreases ✓ (4)
[14]

QUESTION 6

- 6.1 The rate of the forward reaction equals the rate of the reverse reaction./
amount of reactants and products remain the same ✓✓ (2)

6.2

Initial quantity (mol)	SO ₂	O ₂	SO ₃
	$\frac{19,2}{64} = 0,3$ ✓	x	0
Change (mol)	-0,2	-0,1	+0,2
Quantity at equilibrium (mol)	$\frac{6,4}{64} = 0,1$ ✓	x - 0,1	0,2
Equilibrium concentration (mol.dm ⁻³)	$\frac{0,1}{2} = 0,05$	$\frac{x-0,1}{2}$	$\frac{0,2}{2} = 0,1$
			Divide by 2 ✓

$$K_c = \frac{[\text{SO}_3]^2}{[\text{SO}_2]^2 [\text{O}_2]} \quad \checkmark = \frac{(0,1)^2}{(0,05)^2 \left(\frac{x-0,1}{2}\right)} \quad \checkmark = 160$$

$$x = 0,15 \text{ mol}$$

(8)

6.3

- 6.3.1 When the equilibrium in a closed system is disturbed, the system will re-instate a new equilibrium by favouring the reaction that will oppose the disturbance. ✓✓ (2 or 0) (2)
- 6.3.2 exothermic ✓
K_c decreases: concentration of products decreases while concentration of reactants increases ✓
Reverse reaction is favoured ✓
According to Le Chatelier's Principle an increase in temperature Favours the endothermic reaction ✓ (4)
[16]

QUESTION 7

7.1

7.1.1 the reaction of a salt with water ✓✓ (2)

7.1.2 greater than ✓ (1)

7.1.3 $\text{CH}_3\text{COO}^- + \text{H}_2\text{O} \rightleftharpoons \text{CH}_3\text{COOH} + \text{OH}^-$ LHS ✓ RHS ✓ BAL ✓ (3)

7.2

7.2.1 a substance that produces hydrogen ions/hydronium ions/oxonium ions/ H_3O^+ when it dissolves in water. ✓✓ (2)

7.2.2 it ionises to produce ONE proton ✓ (1)

7.3

7.3.1 Q ✓

Reaction is between a strong acid and a strong base. ✓ OR (2)
pH at the endpoint will be approximately 7. ✓

7.3.2

Option 1: $n(\text{HCl}) = 2n(\text{Ba}(\text{OH})_2)$ ✓ $= 2cV$ ✓ $= 2(0,1) \times (0,06)$ ✓ $= 0,012 \text{ mol}$ $c(\text{HCl}) = n/V$ ✓ $= \frac{0,012}{0,035}$ ✓ $c = 0,343 \text{ dm}^3$ ✓	Option 2: $\frac{c_A}{c_B} = \frac{V_A}{V_B} = \frac{n_A}{n_B}$ ✓ $\frac{c_A}{(0,1)} = \frac{(35)}{(60)}$ ✓ $c_A = \frac{2}{1}$ ✓ $c_A = 0,343 \text{ mol} \cdot \text{dm}^{-3}$ ✓
--	---

$c_1V_1 = c_2V_2$ for equating moles of H⁺/OH⁻ balanced
 $c(0,1) = (0,343)(50)$ ✓
 $c = 1,715 \text{ mol} \cdot \text{dm}^{-3}$ ✓

0,343 mol HCl in 1 dm³ ✓
 x mol HCl in 0,050 dm³ }
 $x = 0,0171 \text{ mol}$
 $c = n/V$
 $= 0,0171/0,01$ ✓
 $= 1,71 \text{ mol} \cdot \text{dm}^{-3}$ ✓

(9)

[20]

TOTAL MARKS: 100