



education

DEPARTMENT: EDUCATION
MPUMALANGA PROVINCE

**NATIONAL
SENIOR CERTIFICATE**

GRADE 12

PHYSICAL SCIENCES: CHEMISTRY (P2)

SEPTEMBER 2018

MARKS: 150

TIME: 3 hours

This question paper consists of 16 pages and 4 data sheets.

INSTRUCTIONS AND INFORMATION

1. Write your name in the appropriate space on the ANSWER BOOK.
2. This question paper consists of TEN questions. Answer ALL the questions in the ANSWER BOOK.
3. Start EACH question on a NEW page in the ANSWER BOOK.
4. Number the answers correctly according to the numbering system used in this question paper.
5. Leave ONE line between two sub questions, for example between QUESTION 2.1 and QUESTION 2.2.
6. You may use a non-programmable calculator.
7. You may use appropriate mathematical instruments.
8. You are advised to use the attached DATA SHEETS.
9. Show ALL formulae and substitutions in ALL calculations.
10. Round off your final numerical answers to a MINIMUM of TWO decimal places.
11. Give brief motivations, discussions, etcetera where required.
12. Write neatly and legibly.

QUESTION 1 : MULTIPLE-CHOICE QUESTIONS

Various options are provided as possible answers to the following questions. Choose the answer and write down the letter (A-D) next to the question number (1.1-1.10) in the ANSWER BOOK, for example 1.11 D.

1.1 Consider the organic compound below:

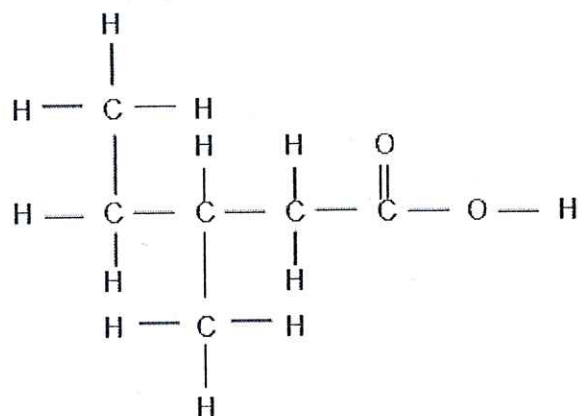

The IUPAC name of this compound is:

- A 1,2-dimethylbutanoic acid
- B 3-methylpentanoic acid
- C hexanoic acid
- D 1-ethyl-1-methylpropanoic acid (2)

1.2 The complete combustion of propane is represented by the balanced equation below:

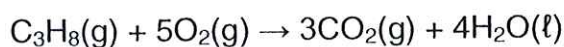

30 cm³ of propane is mixed with 200 cm³ of oxygen and the mixture is ignited. What is the volume, in cm³, of the CO₂ in the resulting gas mixture? (All the volumes are measured at the same temperature and pressure)

- A 230
- B 140
- C 120
- D 90 (2)

1.3 Consider the following diagram:

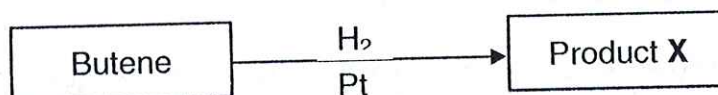

The name of product X as well as the type of reaction taking place respectively, are:

	Product X	Type of reaction
A	dichlorobutene	hydration
B	butadiene	addition
C	butane	hydrogenation
D	butyne	elimination

1.4 The Maxwell-Boltzmann distribution curves below show the number of particles as a function of their kinetic energy for a reaction, at four different temperatures. The minimum kinetic energy needed for effective collisions to take place, is represented by E .

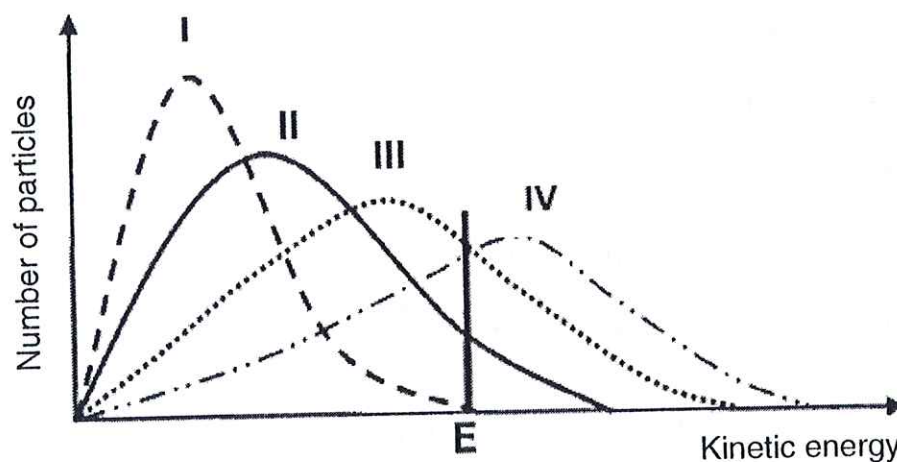

Which ONE of the curves represents the reaction that takes place at the highest temperature?

- A I
- B II
- C III
- D IV

(2)

1.5 The reaction represented by the equation below, reaches equilibrium.

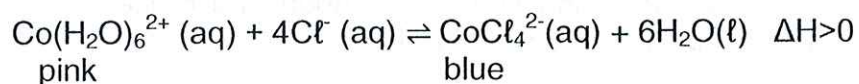

Which ONE of the following changes in the reaction mixture will change the colour from blue to pink?

- A Add a catalyst.
- B Heat the reaction mixture.
- C Add a few drops of concentrated hydrochloric acid in the reaction mixture.
- D Put the reaction mixture in ice. (2)

1.6 Which ONE is the conjugated acid of HC_2O_4^- ?

- A $\text{C}_2\text{O}_4^{2-}$
- B OH^-
- C $\text{H}_2\text{C}_2\text{O}_4$
- D $\text{H}_2\text{C}_2\text{O}_4^-$ (2)

1.7 Which ONE of the following solutions can be stored in an aluminium container?

- A $\text{CuSO}_4(\text{aq})$
- B $\text{ZnSO}_4(\text{aq})$
- C $\text{NaCl}(\text{aq})$
- D $\text{Pb}(\text{NO}_3)_2(\text{aq})$

1.8 In all electrochemical cells, the cathode is always the ...

- A positive electrode.
- B negative electrode.
- C electrode where reduction takes place.
- D electrode where oxidation takes place. (2)

1.9 Which ONE of the following statements about the process of extraction of aluminium in an electrolytic cell, is TRUE?

- A Carbon dioxide is released at the anode.
- B Aluminium forms at the anode.
- C The oxygen formed at the anode, reacts with the aluminium.
- D Carbon dioxide gas is released at the cathode.

(2)

1.10 The process in industry whereby nitrogen gas is prepared, is called:

- A Contact process.
- B Fractional distillation
- C Ostwald process.
- D Haber process

(2)
[20]

QUESTION 3 (Start on a new page)

A learner received four bottles containing different organic compounds. He took a sample from each bottle and determined the boiling point of each under the same conditions. The results are shown in the table below.

	Compound	Molecular formula	Molecular mass ($\text{g}\cdot\text{mol}^{-1}$)	Boiling point ($^{\circ}\text{C}$)
A	Ethane	C_2H_6	30,0	-89
B	Chloroethane	$\text{C}_2\text{H}_5\text{Cl}$	64,5	12
C	Ethanol	$\text{C}_2\text{H}_6\text{O}$	46,0	78
D	Ethanoic acid	$\text{C}_2\text{H}_4\text{O}_2$	60,0	118

- 3.1 Define the term *boiling point*. (2)
- 3.2 For this experiment write down the:
- 3.2.1 Independent variable. (1)
- 3.2.2 The variable that was controlled during the investigation. (1)
- 3.3 From the table, write down the letter (**A**, **B**, **C** or **D**) of a compound that will be in gas phase at 10°C . (1)
- 3.4 Write down the type of intermolecular force (Van der Waals force) between the molecules of each of the following compounds:
- 3.4.1 Compound **A** (1)
- 3.4.2 Compound **B** (1)
- 3.5 Which ONE of compound **A** or **B**, will have the higher vapour pressure at a given temperature? Refer to the data in the table and explain your answer. (2)
- 3.6 Explain the difference in the boiling points of compounds **C** and **D**. (3)
- 3.7 How will the boiling point of the ester, methyl methanoate compare to that of compound **D**? Choose from HIGHER THAN or LOWER THAN. (1)

QUESTION 4 (Start on a new page)

The flow diagram below shows how alcohols react to form other organic compounds.

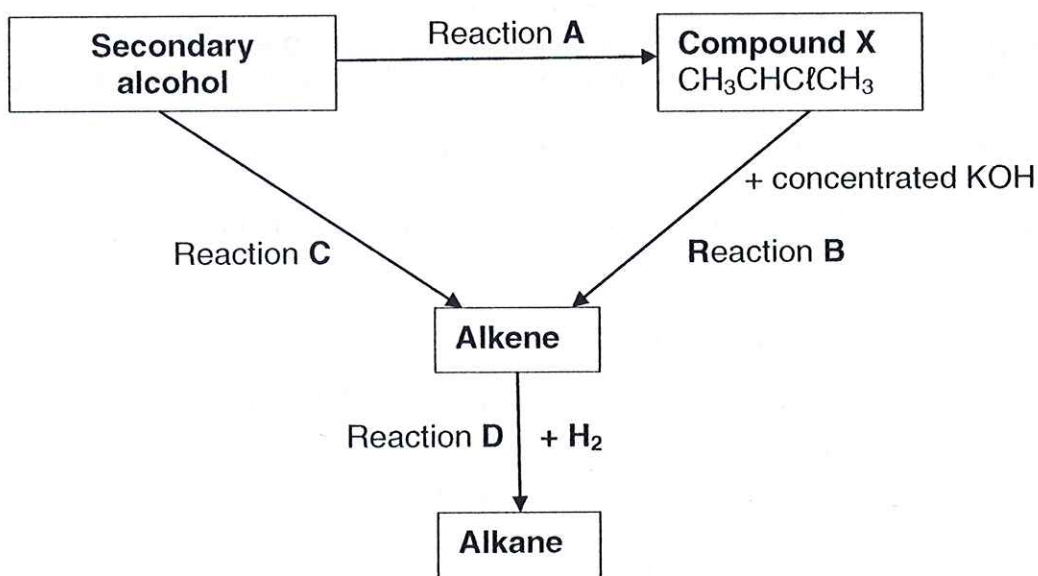

4.1 Write down the type of reaction represented by reaction:

4.1.1 **A** (1)

4.1.2 **B** (1)

4.1.3 **D** (1)

4.2 In reaction **B**, compound **X** is converted to an alkene. Write down the:

4.2.1 IUPAC name of compound **X**. (2)

4.2.2 Balanced equation for the reaction **B**, using structural formulae. (4)

4.3 Reaction **C** takes place in the presence of a strong acid.

4.3.1 Explain the term *secondary alcohol*. (2)

4.3.2 Write down the IUPAC name of the alcohol used. (2)

[13]

QUESTION 5 (Start on a new page)

The following apparatus was used by a group of learners in an investigation to find out how surface area affects the rate of the reaction.

In both experiments, magnesium with the same mass (25g) were used.

In EXPERIMENT I, small pieces were used. In EXPERIMENT II, one big piece was used.

100 cm³ of a 0,1 mol·dm⁻³ hydrochloric acid solution was used in both experiments.

During the reaction, the gas that formed, was collected in the gas syringe which measures the volume of gas produced.

The balanced equation for the reaction is:

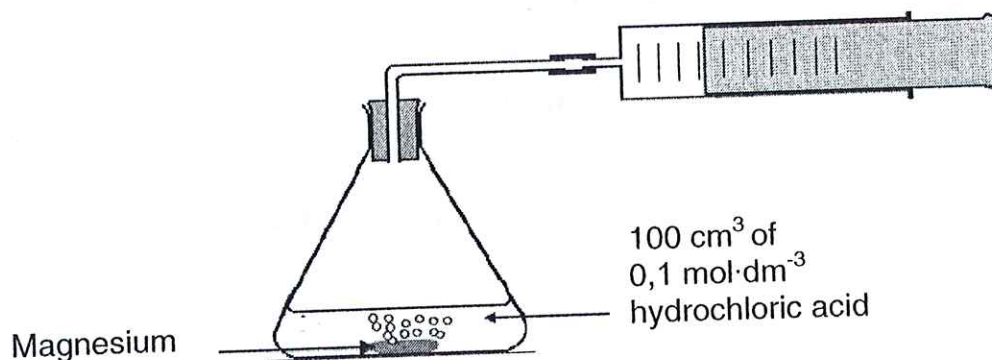
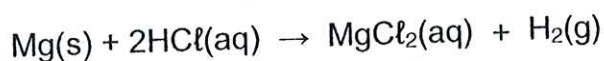

The learners performed the experiments and plotted a graph of their results for EXPERIMENT I, which is represented below.

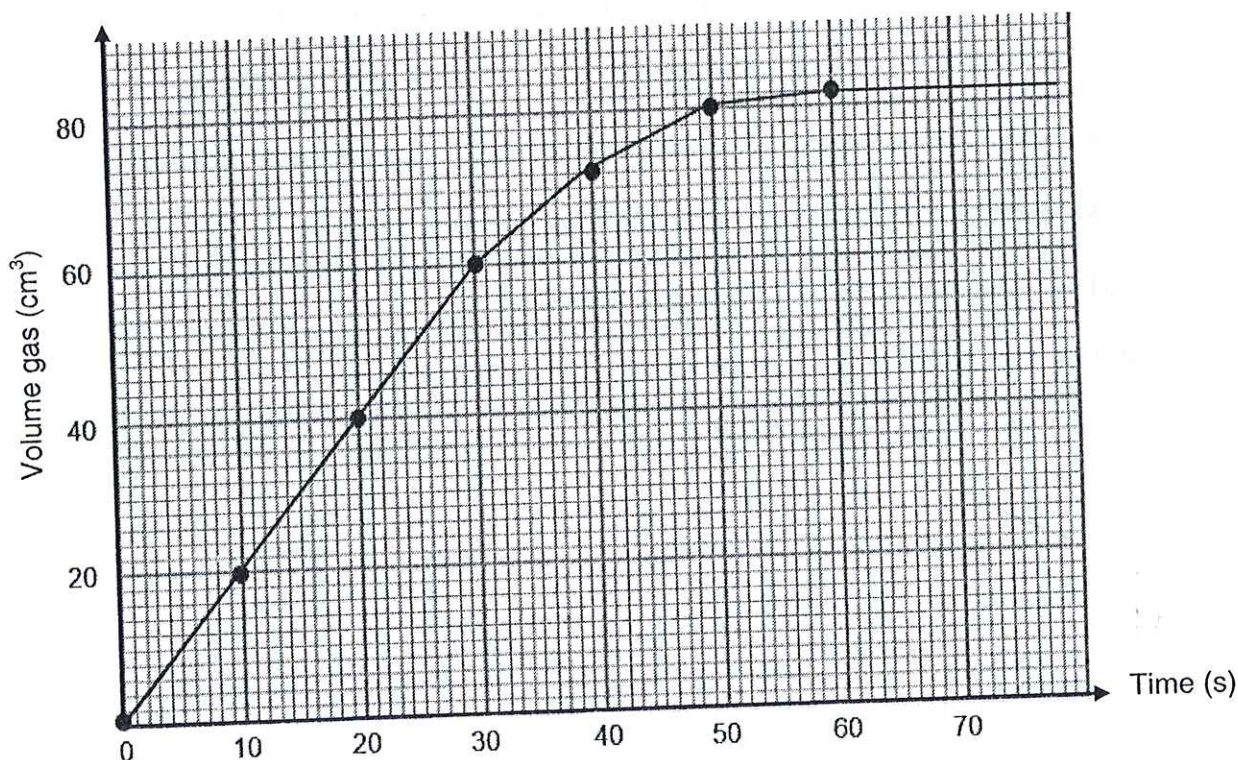

- 5.1 Write down the dependent variable for this investigation. (1)
- 5.2 Besides the mass and the concentration of the reactants, give ONE other variable that must be kept constant during this investigation. (1)
- 5.3 Use the graph to calculate the average rate of the reaction (in $\text{dm}^3 \cdot \text{s}^{-1}$) for the first 30 seconds. (3)
- 5.4 Predict how the gradient of EXPERIMENT II would compare to that of EXPERIMENT I plotted in the graph. Choose from GREATER THAN, LESS THAN or EQUAL TO. (1)
- 5.5 Use the collision theory to explain how the increase in surface area of the magnesium affects the rate of the reaction. (3)
- 5.6 Calculate the mass of magnesium that remains after the reaction has been completed. (6)

[15]

QUESTION 6 (Start on a new page)

The reaction represented by the equation below, reaches equilibrium in a closed container at a certain temperature.

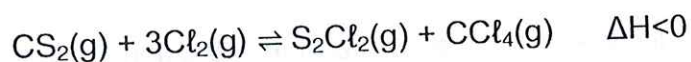

- 6.1 Is the above equilibrium a HOMOGENEOUS or a HETEROGENEOUS equilibrium? (1)
- 6.2 Give a reason for the answer in QUESTION 6.1. (2)
- 6.3 Initially 1,2 moles of $\text{CS}_2(\text{g})$ and 4 moles of $\text{Cl}_2(\text{g})$ are injected into a 2 dm^3 sealed container. Analysis of the equilibrium mixture shows that 138,6 g of $\text{CCl}_4(\text{g})$ is present. Calculate the equilibrium constant (K_c) at this temperature. (8)
- 6.4 More S_2Cl_2 is added to the equilibrium mixture at a constant temperature and pressure. How will this change the following?
Choose from: INCREASES, DECREASES or REMAINS THE SAME. (1)
- 6.4.1 Concentration of $\text{CCl}_4(\text{g})$. (1)
- 6.4.2 Number of moles of Cl_2 . (1)
- 6.4.3 Value of the equilibrium constant (K_c). (1)
- 6.5 Use Le Chatelier's principle to explain the answer in QUESTION 6.4.2. (3)

The graph below shows the change in the rate of reaction after further changes were made to the above equilibrium mixture.

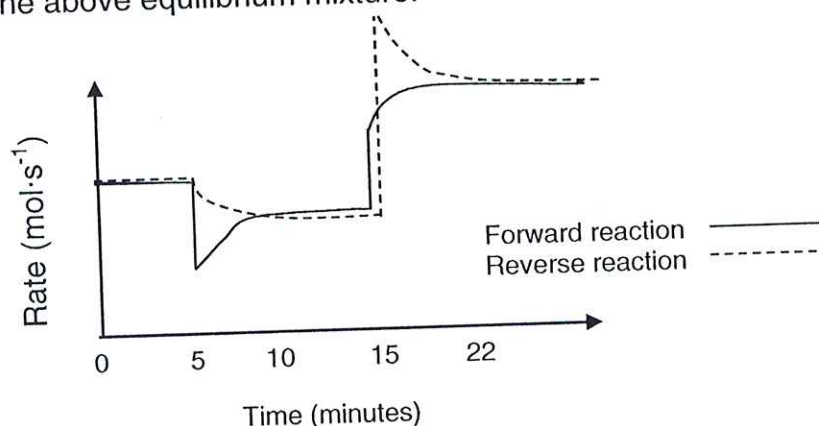

- 6.6 Write down a possible disturbance, other than temperature, responsible for the sudden change in reaction rate in the 5th minute. (1)
- 6.7 If the change in reaction rate at the 15th minute is due to a change in temperature, did the temperature INCREASE or DECREASE? (1)
- 6.8 Refer to the graph and explain the answer in QUESTION 6.7. (1)

[20]

QUESTION 7 (Start on a new page)

- 7.1 Give a reason why sodium hydroxide is classified as a *strong base*. (2)
- 7.2 Determine the pH of a $0,2 \text{ mol}\cdot\text{dm}^{-3}$ solution of H_2SO_4 at 25°C . (3)
- 7.3 Calculate the concentration of a NaOH solution with a pH of 13. (3)
- 7.4 A few crystals of sodium carbonate (Na_2CO_3) are added to water in a test tube.
- 7.4.1 Is the solution in the test tube ACIDIC, BASIC or NEUTRAL? (1)
- 7.4.2 Use a balanced equation to explain your answer in QUESTION 7.4.1. (2)
- 7.5 A 25 g sample of impure sodium carbonate (Na_2CO_3) is treated with EXCESS dilute sulphuric acid.

The balanced chemical equation for the reaction is:

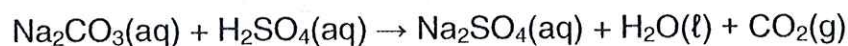

During the reaction, $4,48 \text{ dm}^3$ of carbon dioxide gas is collected at STP.
Calculate the percentage purity of the sodium carbonate. (5)

[16]

QUESTION 8 (Start on a new page)

A galvanic cell is set up based on the reaction represented by the equation below. The reaction takes place under standard conditions.

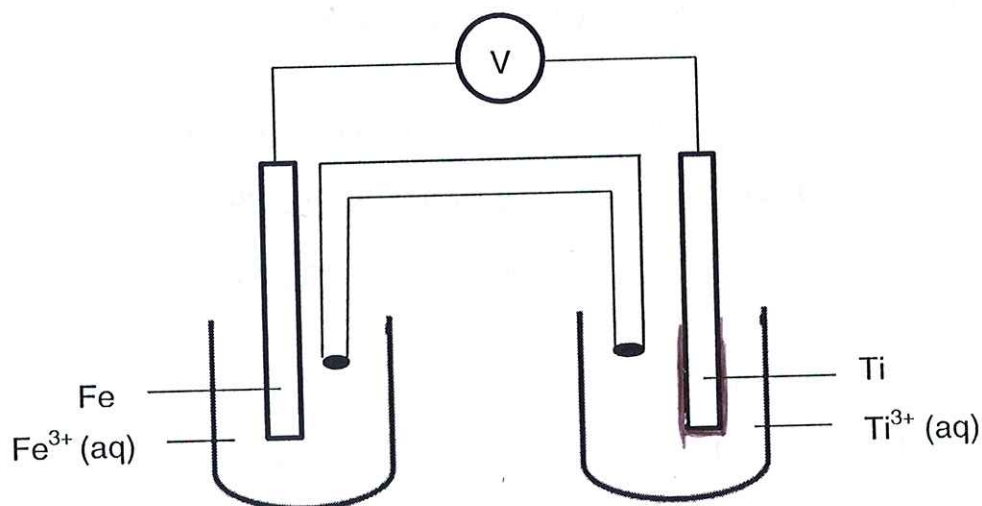
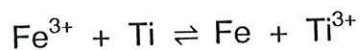

- 8.1 Define the term *oxidation* in terms of oxidation number. (2)
- 8.2 State TWO functions of the salt bridge. (2)
- 8.3 Write down the:
- 8.3.1 Half-reaction that takes place at the cathode. (2)
- 8.3.2 Cell notation for this cell. (3)
- 8.4 The initial reading on the voltmeter is 1,57 V.
Calculate the standard reduction potential of the Ti electrode. (4)
- 8.5 Write down the value of the reading on the voltmeter when the cell reaction reaches equilibrium. (1)

[14]

QUESTION 9 (Start on a new page)

High purity silver is obtained by electrolysis using a thin, pure silver cathode and an acidified solution of silver sulphate.

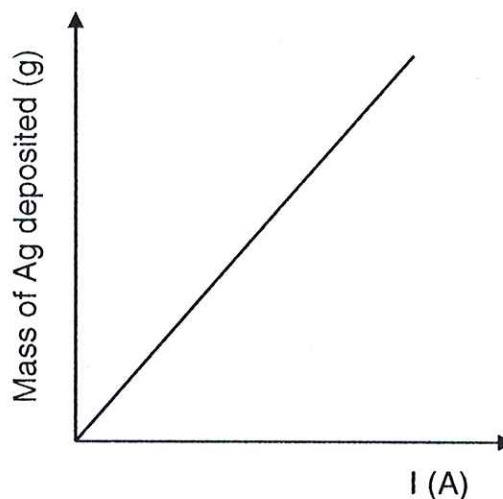
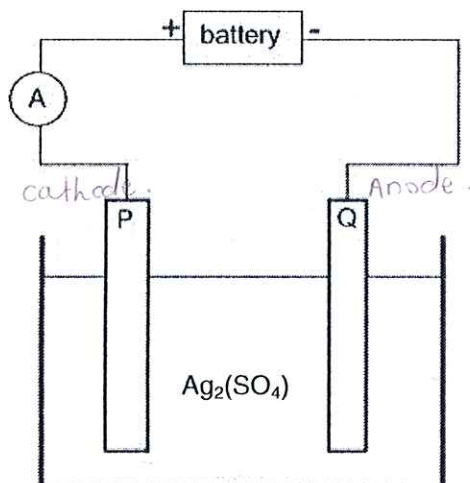

- 9.1 Define the term *electrolysis*. (2)
- 9.2 Write down the:
- 9.2.1 Half reaction that takes place at the anode. (2)
- 9.2.2 Nett cell reaction that takes place in the cell. (2)
- 9.3 State the relationship between CURRENT and the MASS DEPOSITED depicted by the graph. (1)
- 9.4 When a constant current flows for 60 min, 17 g of pure silver is deposited at one of the electrodes.
- 9.4.1 At which electrode, **P** or **Q**, will the silver be deposited? (1)
- 9.4.2 Would the mass loss at the other electrode be LARGER THAN, SMALLER THAN or EQUAL TO 17 g? (1)
- 9.4.3 Calculate the number of moles of silver deposited. (2)
- 9.4.4 Calculate the number of electrons transferred. (2)

[13]

QUESTION 10 (Start on a new page)

- 10.1 The flow diagram below represents the processes used to manufacture fertilizer **A**. Both the Haber and the Ostwald processes are part of the total process.

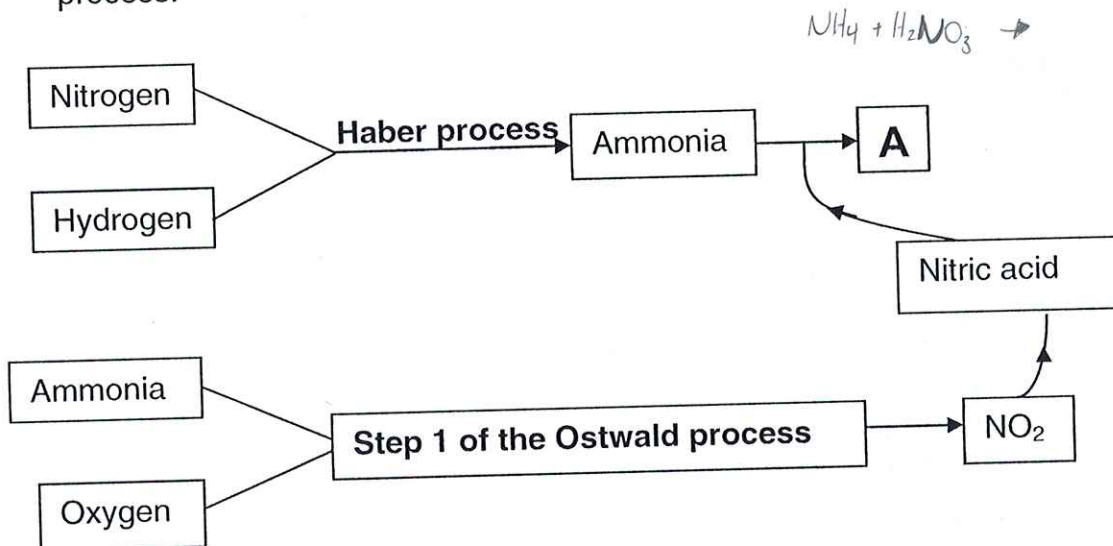

- 10.1.1 Write down the name of a suitable catalyst used in the Haber process. (1)
- 10.1.2 Write down the FORMULA of the compound represented by **A**. (1)
- 10.1.3 Write down a balanced chemical equation for **Step 1** of the Ostwald process. (3)

- 10.2 You want to start a vegetable garden in your community. You obtain the following bags of fertilisers as described below.

NPK $\%N = \frac{4}{19} \times 43 = 9,052\%$ $\%P = \frac{9}{19} \times 45 = 13,58\%$ $\%K = \frac{9}{19} \times 45 = 20,37\%$
X: 4:6:9 (43)
Y: 15:3:3 (51) $N = \frac{15}{21} \times 51 = 36,43\%$ $P = \frac{3}{21} \times 51 = 7,29\%$ $K = \frac{3}{21} \times 51 = 7,29\%$

- 10.2.1 From fertilisers **X** and **Y**, choose a fertiliser which is most suitable for the growth of tomatoes. (1)
- 10.2.2 Give a reason for the answer in QUESTION 10.2.1. (1)
- 10.2.3 Calculate the mass of potassium in a 20 kg bag of fertiliser **Y**. (3)

[10]

TOTAL: 15

**DATA FOR PHYSICAL SCIENCES GRADE 12
PAPER 2 (CHEMISTRY)**

**GEGEWENS VIR FISIESTE WETENSKAPPE GRAAD 12
VRAESTEL 2 (CHEMIE)**

TABLE 1: PHYSICAL CONSTANTS/TABEL 1: FISIESTE KONSTANTES

NAME/NAAM	SYMBOL/SIMBOOL	VALUE/WAARDE
Standard pressure <i>Standaarddruk</i>	p^θ	$1,013 \times 10^5 \text{ Pa}$
Molar gas volume at STP <i>Molêre gasvolume by STD</i>	V_m	$22,4 \text{ dm}^3 \cdot \text{mol}^{-1}$
Standard temperature <i>Standaardtemperatuur</i>	T^θ	273 K
Charge on electron <i>Lading op elektron</i>	e	$-1,6 \times 10^{-19} \text{ C}$
Avogadro's constant <i>Avogadro-konstante</i>	N_A	$6,02 \times 10^{23} \text{ mol}^{-1}$

TABLE 2: FORMULAE/TABEL 2: FORMULES

$n = \frac{m}{M}$	$n = \frac{N}{N_A}$
$c = \frac{n}{V}$ or/of $c = \frac{m}{MV}$	$n = \frac{V}{V_m}$
$\frac{c_a V_a}{c_b V_b} = \frac{n_a}{n_b}$	$\text{pH} = -\log[\text{H}_3\text{O}^+]$
$K_w = [\text{H}_3\text{O}^+][\text{OH}^-] = 1 \times 10^{-14} \text{ at/by } 298 \text{ K}$	
$E_{\text{cell}}^\theta = E_{\text{cathode}}^\theta - E_{\text{anode}}^\theta$ / $E_{\text{sel}}^\theta = E_{\text{katode}}^\theta - E_{\text{anode}}^\theta$ or/of $E_{\text{cell}}^\theta = E_{\text{reduction}}^\theta - E_{\text{oxidation}}^\theta$ / $E_{\text{sel}}^\theta = E_{\text{reduksie}}^\theta - E_{\text{oksidasie}}^\theta$ or/of $E_{\text{cell}}^\theta = E_{\text{oxidising agent}}^\theta - E_{\text{reducing agent}}^\theta$ / $E_{\text{sel}}^\theta = E_{\text{oksideermiddel}}^\theta - E_{\text{reduseermiddel}}^\theta$	

TABLE 3: THE PERIODIC TABLE OF ELEMENTS
TABEL 3: DIE PERIODIEKE TABEL VAN ELEMENTE

1	2	3	4	5	6	7	8	9	10	11	12	13	14	15	16	17	18
(I)	(II)	KEY/SLEUTEL										(III)	(IV)	(V)	(VI)	(VII)	(VIII)
1 H 1,0	2 He 4	3 Li 7	4 Be 9	5 B 10,8	6 C 12	7 N 14	8 O 16	9 F 19	10 Ne 20	11 Na 23	12 Mg 24	13 Al 27	14 Si 28	15 P 31	16 S 32	17 Cl 35,5	18 Ar 40
19 K 39	20 Ca 40	21 Sc 45	22 Ti 48	23 V 51	24 Cr 52	25 Mn 55	26 Fe 56	27 Co 59	28 Ni 59	29 Cu 63,5	30 Zn 65	31 Ga 70	32 Ge 73	33 As 75	34 Se 79	35 Br 80	36 Kr 84
37 Rb 86	38 Sr 88	39 Y 89	40 Zr 91	41 Nb 92	42 Mo 96	43 Tc 98	44 Ru 101	45 Rh 103	46 Pd 106	47 Ag 108	48 Cd 112	49 In 115	50 Sn 119	51 Sb 122	52 Te 128	53 I 127	54 Xe 131
55 Cs 133	56 Ba 137	57 La 139	72 Hf 179	73 Ta 181	74 W 184	75 Re 186	76 Os 190	77 Ir 192	78 Pt 195	79 Au 197	80 Hg 201	81 Tl 204	82 Pb 207	83 Bi 209	84 Po 209	85 At	86 Rn
87 Fr 226	88 Ra 226	89 Ac	89 Ac	89 Ac	89 Ac	89 Ac	89 Ac	89 Ac	89 Ac	89 Ac	89 Ac	89 Ac	89 Ac	89 Ac	89 Ac	89 Ac	89 Ac

58 Ce 140	59 Pr 141	60 Nd 144	61 Pm	62 Sm 150	63 Eu 152	64 Gd 157	65 Tb 159	66 Dy 163	67 Ho 165	68 Er 167	69 Tm 169	70 Yb 173	71 Lu 175
90 Th 232	91 Pa	92 U 238	93 Np	94 Pu	95 Am	96 Cm	97 Bk	98 Cf	99 Es	100 Fm	101 Md	102 No	103 Lr

29 Cu 63,5	Symbol Simbool
------------------	-------------------

29 Cu 63,5	Atomic number Atoomgetal
------------------	-----------------------------

29 Cu 63,5	Electronegativity Elektronegatiwiteit
------------------	--

29 Cu 63,5	Approximate relative atomic mass Benaderde relatiewe atoommassa
------------------	--

TABLE 4A: STANDARD REDUCTION POTENTIALS
TABEL 4A: STANDAARD-REDUKSIEPOTENSIALE

Half-reactions/Halfreaksies	E° (V)
$F_2(g) + 2e^- \rightleftharpoons 2F^-$	+ 2,87
$Co^{3+} + e^- \rightleftharpoons Co^{2+}$	+ 1,81
$H_2O_2 + 2H^+ + 2e^- \rightleftharpoons 2H_2O$	+1,77
$MnO_4^- + 8H^+ + 5e^- \rightleftharpoons Mn^{2+} + 4H_2O$	+ 1,51
$Cl_2(g) + 2e^- \rightleftharpoons 2Cl^-$	+ 1,36
$Cr_2O_7^{2-} + 14H^+ + 6e^- \rightleftharpoons 2Cr^{3+} + 7H_2O$	+ 1,33
$O_2(g) + 4H^+ + 4e^- \rightleftharpoons 2H_2O$	+ 1,23
$MnO_2 + 4H^+ + 2e^- \rightleftharpoons Mn^{2+} + 2H_2O$	+ 1,23
$Pt^{2+} + 2e^- \rightleftharpoons Pt$	+ 1,20
$Br_2(l) + 2e^- \rightleftharpoons 2Br^-$	+ 1,07
$NO_3^- + 4H^+ + 3e^- \rightleftharpoons NO(g) + 2H_2O$	+ 0,96
$Hg^{2+} + 2e^- \rightleftharpoons Hg(l)$	+ 0,85
$Ag^+ + e^- \rightleftharpoons Ag$	+ 0,80
$NO_3^- + 2H^+ + e^- \rightleftharpoons NO_2(g) + H_2O$	+ 0,80
$Fe^{3+} + e^- \rightleftharpoons Fe^{2+}$	+ 0,77
$O_2(g) + 2H^+ + 2e^- \rightleftharpoons H_2O_2$	+ 0,68
$I_2 + 2e^- \rightleftharpoons 2I^-$	+ 0,54
$Cu^+ + e^- \rightleftharpoons Cu$	+ 0,52
$SO_2 + 4H^+ + 4e^- \rightleftharpoons S + 2H_2O$	+ 0,45
$2H_2O + O_2 + 4e^- \rightleftharpoons 4OH^-$	+ 0,40
$Cu^{2+} + 2e^- \rightleftharpoons Cu$	+ 0,34
$SO_4^{2-} + 4H^+ + 2e^- \rightleftharpoons SO_2(g) + 2H_2O$	+ 0,17
$Cu^{2+} + e^- \rightleftharpoons Cu^+$	+ 0,16
$Sn^{4+} + 2e^- \rightleftharpoons Sn^{2+}$	+ 0,15
$S + 2H^+ + 2e^- \rightleftharpoons H_2S(g)$	+ 0,14
$2H^+ + 2e^- \rightleftharpoons H_2(g)$	0,00
$Fe^{3+} + 3e^- \rightleftharpoons Fe$	- 0,06
$Pb^{2+} + 2e^- \rightleftharpoons Pb$	- 0,13
$Sn^{2+} + 2e^- \rightleftharpoons Sn$	- 0,14
$Ni^{2+} + 2e^- \rightleftharpoons Ni$	- 0,27
$Co^{2+} + 2e^- \rightleftharpoons Co$	- 0,28
$Cd^{2+} + 2e^- \rightleftharpoons Cd$	- 0,40
$Cr^{3+} + e^- \rightleftharpoons Cr^{2+}$	- 0,41
$Fe^{2+} + 2e^- \rightleftharpoons Fe$	- 0,44
$Cr^{3+} + 3e^- \rightleftharpoons Cr$	- 0,74
$Zn^{2+} + 2e^- \rightleftharpoons Zn$	- 0,76
$2H_2O + 2e^- \rightleftharpoons H_2(g) + 2OH^-$	- 0,83
$Cr^{2+} + 2e^- \rightleftharpoons Cr$	- 0,91
$Mn^{2+} + 2e^- \rightleftharpoons Mn$	- 1,18
$Al^{3+} + 3e^- \rightleftharpoons Al$	- 1,66
$Mg^{2+} + 2e^- \rightleftharpoons Mg$	- 2,36
$Na^+ + e^- \rightleftharpoons Na$	- 2,71
$Ca^{2+} + 2e^- \rightleftharpoons Ca$	- 2,87
$Sr^{2+} + 2e^- \rightleftharpoons Sr$	- 2,89
$Ba^{2+} + 2e^- \rightleftharpoons Ba$	- 2,90
$Cs^+ + e^- \rightleftharpoons Cs$	- 2,92
$K^+ + e^- \rightleftharpoons K$	- 2,93
$Li^+ + e^- \rightleftharpoons Li$	- 3,05

Increasing oxidising ability/Toenemende oksiderende vermoë

Increasing reducing ability/Toenemende reduserende vermoë

NSS

TABLE 4B: STANDARD REDUCTION POTENTIALS
TABEL 4B: STANDAARD-REDUKSIEPOTENSIALE

Increasing oxidising ability/Toenemende oksiderende vermoë

Half-reactions/Halfreaksies	E^{\ominus} (V)
$\text{Li}^+ + \text{e}^- \rightleftharpoons \text{Li}$	-3,05
$\text{K}^+ + \text{e}^- \rightleftharpoons \text{K}$	-2,93
$\text{Cs}^+ + \text{e}^- \rightleftharpoons \text{Cs}$	-2,92
$\text{Ba}^{2+} + 2\text{e}^- \rightleftharpoons \text{Ba}$	-2,90
$\text{Sr}^{2+} + 2\text{e}^- \rightleftharpoons \text{Sr}$	-2,89
$\text{Ca}^{2+} + 2\text{e}^- \rightleftharpoons \text{Ca}$	-2,87
$\text{Na}^+ + \text{e}^- \rightleftharpoons \text{Na}$	-2,71
$\text{Mg}^{2+} + 2\text{e}^- \rightleftharpoons \text{Mg}$	-2,36
$\text{Al}^{3+} + 3\text{e}^- \rightleftharpoons \text{Al}$	-1,66
$\text{Mn}^{2+} + 2\text{e}^- \rightleftharpoons \text{Mn}$	-1,18
$\text{Cr}^{2+} + 2\text{e}^- \rightleftharpoons \text{Cr}$	-0,91
$2\text{H}_2\text{O} + 2\text{e}^- \rightleftharpoons \text{H}_2(\text{g}) + 2\text{OH}^-$	-0,83
$\text{Zn}^{2+} + 2\text{e}^- \rightleftharpoons \text{Zn}$	-0,76
$\text{Cr}^{3+} + 3\text{e}^- \rightleftharpoons \text{Cr}$	-0,74
$\text{Fe}^{2+} + 2\text{e}^- \rightleftharpoons \text{Fe}$	-0,44
$\text{Cr}^{3+} + \text{e}^- \rightleftharpoons \text{Cr}^{2+}$	-0,41
$\text{Cd}^{2+} + 2\text{e}^- \rightleftharpoons \text{Cd}$	-0,40
$\text{Co}^{2+} + 2\text{e}^- \rightleftharpoons \text{Co}$	-0,28
$\text{Ni}^{2+} + 2\text{e}^- \rightleftharpoons \text{Ni}$	-0,27
$\text{Sn}^{2+} + 2\text{e}^- \rightleftharpoons \text{Sn}$	-0,14
$\text{Pb}^{2+} + 2\text{e}^- \rightleftharpoons \text{Pb}$	-0,13
$\text{Fe}^{3+} + 3\text{e}^- \rightleftharpoons \text{Fe}$	-0,06
$2\text{H}^+ + 2\text{e}^- \rightleftharpoons \text{H}_2(\text{g})$	0,00
$\text{S} + 2\text{H}^+ + 2\text{e}^- \rightleftharpoons \text{H}_2\text{S}(\text{g})$	+0,14
$\text{Sn}^{4+} + 2\text{e}^- \rightleftharpoons \text{Sn}^{2+}$	+0,15
$\text{Cu}^{2+} + \text{e}^- \rightleftharpoons \text{Cu}^+$	+0,16
$\text{SO}_4^{2-} + 4\text{H}^+ + 2\text{e}^- \rightleftharpoons \text{SO}_2(\text{g}) + 2\text{H}_2\text{O}$	+0,17
$\text{Cu}^{2+} + 2\text{e}^- \rightleftharpoons \text{Cu}$	+0,34
$2\text{H}_2\text{O} + \text{O}_2 + 4\text{e}^- \rightleftharpoons 4\text{OH}^-$	+0,40
$\text{SO}_2 + 4\text{H}^+ + 4\text{e}^- \rightleftharpoons \text{S} + 2\text{H}_2\text{O}$	+0,45
$\text{Cu}^+ + \text{e}^- \rightleftharpoons \text{Cu}$	+0,52
$\text{I}_2 + 2\text{e}^- \rightleftharpoons 2\text{I}^-$	+0,54
$\text{O}_2(\text{g}) + 2\text{H}^+ + 2\text{e}^- \rightleftharpoons \text{H}_2\text{O}_2$	+0,68
$\text{Fe}^{3+} + \text{e}^- \rightleftharpoons \text{Fe}^{2+}$	+0,77
$\text{NO}_3^- + 2\text{H}^+ + \text{e}^- \rightleftharpoons \text{NO}_2(\text{g}) + \text{H}_2\text{O}$	+0,80
$\text{Ag}^+ + \text{e}^- \rightleftharpoons \text{Ag}$	+0,80
$\text{Hg}^{2+} + 2\text{e}^- \rightleftharpoons \text{Hg}(\ell)$	+0,85
$\text{NO}_3^- + 4\text{H}^+ + 3\text{e}^- \rightleftharpoons \text{NO}(\text{g}) + 2\text{H}_2\text{O}$	+0,96
$\text{Br}_2(\ell) + 2\text{e}^- \rightleftharpoons 2\text{Br}^-$	+1,07
$\text{Pt}^{2+} + 2\text{e}^- \rightleftharpoons \text{Pt}$	+1,20
$\text{MnO}_2 + 4\text{H}^+ + 2\text{e}^- \rightleftharpoons \text{Mn}^{2+} + 2\text{H}_2\text{O}$	+1,23
$\text{O}_2(\text{g}) + 4\text{H}^+ + 4\text{e}^- \rightleftharpoons 2\text{H}_2\text{O}$	+1,23
$\text{Cr}_2\text{O}_7^{2-} + 14\text{H}^+ + 6\text{e}^- \rightleftharpoons 2\text{Cr}^{3+} + 7\text{H}_2\text{O}$	+1,33
$\text{Cl}_2(\text{g}) + 2\text{e}^- \rightleftharpoons 2\text{Cl}^-$	+1,36
$\text{MnO}_4^- + 8\text{H}^+ + 5\text{e}^- \rightleftharpoons \text{Mn}^{2+} + 4\text{H}_2\text{O}$	+1,51
$\text{H}_2\text{O}_2 + 2\text{H}^+ + 2\text{e}^- \rightleftharpoons 2\text{H}_2\text{O}$	+1,77
$\text{Co}^{3+} + \text{e}^- \rightleftharpoons \text{Co}^{2+}$	+1,81
$\text{F}_2(\text{g}) + 2\text{e}^- \rightleftharpoons 2\text{F}^-$	+2,87

Increasing reducing ability/Toenemende reduserende vermoë