



education

DEPARTMENT: EDUCATION
MPUMALANGA PROVINCE

**NATIONAL
SENIOR CERTIFICATE**

GRADE 12

**PHYSICAL SCIENCES: CHEMISTRY (P2)
SEPTEMBER 2016**

MARKS: 150

TIME: 3 hours

This question paper consists of 18 pages and 4 data sheets.

INSTRUCTIONS AND INFORMATION

1. Write your name in the appropriate space on the ANSWER BOOK.
2. This question paper consists of TEN questions. Answer ALL the questions in the ANSWER BOOK.
3. Start EACH question on a NEW page in the ANSWER BOOK.
4. Number the answers correctly according to the numbering system used in this question paper.
5. Leave ONE line between two sub questions, for example between QUESTION 2.1 and QUESTION 2.2.
6. You may use a non-programmable calculator.
7. You may use appropriate mathematical instruments.
8. You are advised to use the attached DATA SHEETS.
9. Show ALL formulae and substitutions in ALL calculations.
10. Round off your final numerical answers to a MINIMUM of TWO decimal places.
11. Give brief motivations, discussions, et cetera where required.
12. Write neatly and legibly.



QUESTION 1 : MULTIPLE-CHOICE QUESTIONS

Four options are provided as possible answers to the following questions. Each question has only ONE correct answer. Choose the answer and write only the letter (A – D) next to the question number (1.1 – 1.10) in the ANSWER BOOK, for example, 1.11 E.

1.1 Which ONE of the following elements is a non-mineral nutrient?

- A Mg
- B Na
- C C
- D Zn

(2)

1.2 Which ONE of the following is a catalyst used in the Haber process?

- A Silica gel
- B Iron oxide
- C Vanadium pentoxide
- D Nickel

(2)

1.3 Consider the following reaction in equilibrium in a closed container.

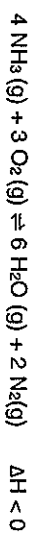

Which ONE of the following changes in the conditions at equilibrium will result in an increase in the value of the equilibrium constant, K_c ?

- A Increasing the ammonia concentration
- B Increasing the temperature
- C Decreasing the temperature
- D Adding a platinum catalyst

(2)

1.4 Which type of reaction is illustrated by the following chemical equation

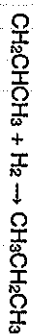

- A Esterification
- B Addition
- C Elimination
- D Substitution

(2)

1.5 A compound with molecular formula $\text{C}_4\text{H}_8\text{O}_2$ could be

- (i) an alcohol
- (ii) a carboxylic acid
- (iii) an ester

Which ONE of the following statements is CORRECT?

- A (i) only
- B (i) and (ii) only
- C (i) and (iii) only
- D (ii) and (iii) only

(2)

1.6 Ammonium sulphate ($(\text{NH}_4)_2\text{SO}_4$) is dissolved in water. Which ONE of the following statements regarding the solution formed, is CORRECT?

- A $\text{pH} = 7$
- B $[\text{H}_3\text{O}^+] \cdot [\text{OH}^-] < 1 \times 10^{-14}$
- C $[\text{H}_3\text{O}^+] > [\text{OH}^-]$
- D $[\text{H}_3\text{O}^+] < [\text{OH}^-]$

(2)

1.7 Consider the reversible reaction represented below:

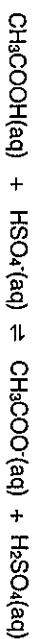

The strongest base in the reaction above is:

- A CH_3COO^-
 - B CH_3COOH
 - C HSO_4^-
 - D H_2SO_4
- (2)

1.8 Which ONE of the following will be changed by the addition of a catalyst?

- A The amount of products present at equilibrium
 - B The concentration of reactants present at equilibrium
 - C The length of time for which the reaction remains at equilibrium
 - D The time it takes to reach equilibrium
- (2)

1.9 A hypothetical electrochemical cell is constructed by combining two half-cells. The two half-reactions and electrode potentials are given below:

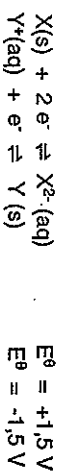

Which ONE of the following statements is TRUE?

- A $\text{X}^{2-}(\text{aq})$ will be oxidised more readily than $\text{Y}(\text{s})$
 - B $\text{Y}^+(\text{aq})$ will be one of the products formed in the cell reaction
 - C The mass of X will increase when the cell is delivering current
 - D Electrons will flow from X (s) to Y (s) in the external circuit when the cell is delivering current
- (2)

1.10 A Zn – Cu cell has been operating for some time but the net cell reaction has not reached equilibrium. How will an increase in the $[\text{Cu}^{2+}]$ affect the emf of the cell?

- A The emf will increase
 - B The emf will decrease
 - C The emf will remain the same
 - D The emf will be zero
- (2)

QUESTION 2 (Start on a new page)

Six organic compounds (A – F) are given in the table below.

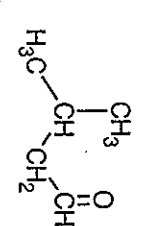
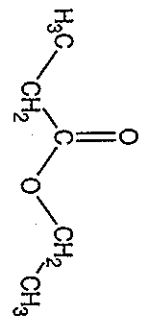
A	$\text{H}_3\text{C}-\overset{\text{OH}}{\text{C}}-\text{CH}_2-\text{CH}_2-\text{CH}_3$	B	$\text{HC}\equiv\text{C}-\text{CH}_2-\text{CH}_2-\text{CH}_3$
C		D	Pentanoic acid
E	$\text{H}_3\text{C}-\overset{\text{CH}_3}{\underset{\text{OH}}{\text{C}}}-\text{CH}_2-\text{CH}_3$	F	

2.1 Write down the:

- 2.1.1 Letter of the compound that represents an aldehyde (1)
- 2.1.2 Structural formula of the functional group of compound D (1)
- 2.1.3 IUPAC name of compound C (2)
- 2.1.4 Letter of the compound that represents a tertiary alcohol (1)
- 2.1.5 Letters of compounds that represents TWO functional isomers (2)
- 2.1.6 To which homologous series does compound B belong? (1)
- 2.1.7 Is compound B SATURATED or UNSATURATED? Explain the answer. (3)

QUESTION 3 (Start on a new page)

- 2.2 Compound F is prepared in the laboratory.
- 2.2.1 How can one quickly establish whether compound F is indeed being formed without performing a chemical test? (1)
- 2.2.2 Give the IUPAC name of the alcohol needed to prepare compound F. (2)

[14]

QUESTION 3 (Start on a new page)

The boiling points of pentane, 2-methylbutane and 2,2-dimethylpropane were determined during a practical investigation and recorded in the table below.

ALKANE	MOLECULAR MASS (g.mol ⁻¹)	BOILING POINT (°C)
Pentane	72	36
2-methylbutane	72	28
2,2-dimethylpropane	72	10

- 3.1 Define the term *boiling point*. (2)
- 3.2 State a suitable hypothesis for the investigation. (2)
- 3.3 Fully explain why pentane has the highest boiling point. (4)
- 3.4 Which ONE of the three compounds in the table has the highest vapour pressure? Give a reason for the answer (2)
- 3.5 Write down the balanced equation for the complete combustion of pentane. (3)

[13]

QUESTION 4 (Start on a new page)

4.1 The flow diagram shows how two compounds can be formed from 2-bromopentane.

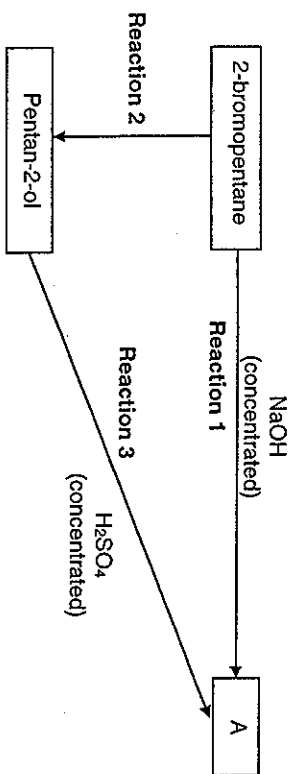

Reaction 1 takes place in the presence of concentrated sodium hydroxide. Write down:

- 4.1.1 An additional reaction condition for this reaction (1)
- 4.1.2 The type of reaction of which Reaction 1 is an example (1)
- 4.1.3 The structural formula of compound A (2)
- Reaction 2 takes place in the presence of a certain inorganic compound. Write down the:
- 4.1.4 NAME of the inorganic compound (1)
- 4.1.5 Type of reaction of which Reaction 2 is an example. (1)
- Reaction 3 takes place in the presence of concentrated sulphuric acid and heat.
- 4.1.6 Write down the type of reaction that converts pentan-2-ol to compound A. (1)

4.2

A learner is preparing an ester using ethanol (molecular formula: C_2H_5OH) and methanoic acid (molecular formula: CH_2O_2).

The balanced equation for the reaction is given below:

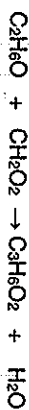

- 4.2.1 What type of reaction is represented in the equation above? (1)
- 4.2.2 Write down the NAME or FORMULA of the catalyst used in this reaction. (1)
- 4.2.3 When 60 g of impure ethanol fully reacts with excess methanoic acid, 68 g of $C_3H_6O_2$ is produced. Calculate the percentage purity of ethanol. (6)
- 4.3 The structural formula of a polymer is shown below:

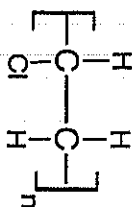

- Write down the:
- 4.3.1 STRUCTURAL FORMULA of the monomer that is used to prepare the above polymer. (2)
- 4.3.2 Type of polymerisation reaction (ADDITION or CONDENSATION) that is used to prepare this polymer. (1)

[18]

QUESTION 5 (Start on a new page)

A group of learners use the reaction between zinc and sulphuric acid to investigate one of the factors that affects reaction rate.

They add 6,5 g of zinc granules to excess **DILUTE** sulphuric acid and measure the mass of zinc used per unit time.

The learners then repeat the experiment using the same mass of zinc granules with excess **CONCENTRATED** sulphuric acid.

The balanced equation for the reaction is:



- 5.1 Define the term *reaction rate* (in words). (2)
- 5.2 Write down the independent variable. (1)
- 5.3 The results obtained for the reaction using **DILUTE** sulphuric acid are represented in the graph below:

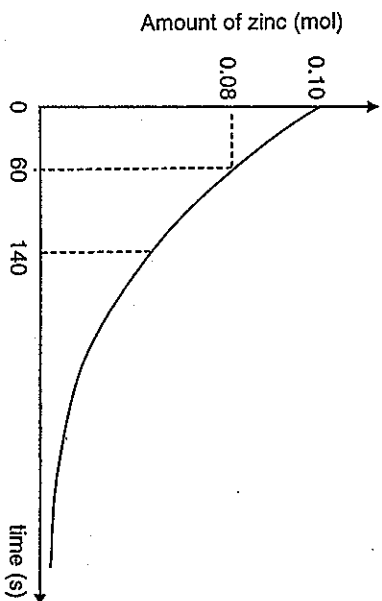

- Use the graph to answer the questions below:
- 5.3.1 Calculate the average rate of the reaction during the first 60 s in gram per second (5)
- 5.3.2 Compare the rate of reaction at time = 140 s to the rate of reaction at time = 60 s. Choose from **GREATER THAN**, **LESS THAN** or **EQUAL TO**. (1)

The Maxwell-Boltzmann distribution curve below represents the number of particles against kinetic energy for the reaction of zinc with **DILUTE** sulphuric acid. The graph is labelled **A**.

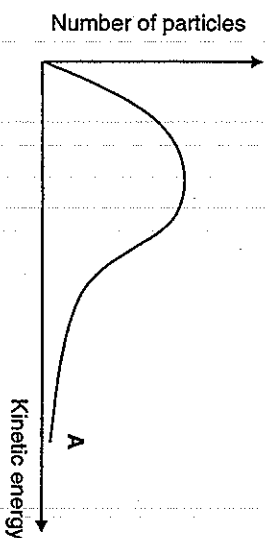

- 5.4 Redraw the curve in the **ANSWER BOOK**. On the same set of axes, sketch the curve that will be obtained for the reaction with **CONCENTRATED** sulphuric acid. Clearly label the curves **A** and **B**. (2)
- 5.5 Use the collision theory to explain how an increase in the concentration of sulphuric acid will affect the rate of reaction (3)

[14]

QUESTION 6 (Start on a new page)

2 moles of carbon dioxide (CO_2), 1 mole of hydrogen (H_2) and 0,2 mole of carbon monoxide (CO) are sealed in a 2 dm³ container. The reaction reaches equilibrium at 1 000°C. The balanced equation for the reaction is:

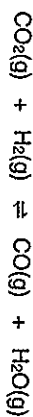

On analysis of the equilibrium mixture, it is found that the concentration of the water vapour is 0,362 mol·dm⁻³.

6.1 Calculate the equilibrium constant (K_c) at 1 000°C for this reaction. (7)

6.2 It is found that at a temperature of 1 500°C, the value of the equilibrium constant calculated in QUESTION 6.1, decreases. Is the forward reaction EXOTHERMIC or ENDOTHERMIC? Fully explain how you arrived at the answer. (4)

6.3 An additional 0,277 mole of water vapour is pumped into the sealed 2 dm³ container. The volume of the container stays the same. Equilibrium is reinstated at 1 000°C.

6.3.1 How is the concentration of the CO (g) affected? Choose from INCREASES, DECREASES or STAYS THE SAME. (1)

6.3.2 Use Le Chatelier's Principle to explain the answer in QUESTION 6.3.1. (3)

[151]



QUESTION 7 (Start on a new page)

7.1 Sulphuric acid is a strong diprotic acid.

Define the term *strong acid*

7.2 HSO_4^- can behave either as an acid or a base.

7.2.1 Give the term that is used for substances such as HSO_4^- .

(1)

7.2.2 Write down the balanced equation for the reaction of HSO_4^- with H_2O in which HSO_4^- acts as an acid.

(2)

7.3 Calculate the pH of a $\text{Mg}(\text{OH})_2$ solution with a concentration of 0,2 mol·dm⁻³. Assume that $\text{Mg}(\text{OH})_2$ dissociates completely.

(4)

7.4 Vinegar is (3 – 5)% ethanoic acid by mass, with the remaining mass being a solvent. To determine the percentage of ethanoic acid in a vinegar sample, it is titrated against a NaOH solution. The balanced equation for the reaction is:



A 10 g sample of vinegar is titrated against a 0,309 mol·dm⁻³ NaOH solution. 19,57 cm³ of NaOH is required to reach end point.

7.4.1 Determine the mass of the ethanoic acid in the 10 g sample. (5)

7.4.2 Show by calculation that the percentage of the ethanoic acid is within the given range. (2)

The table below provides information of three different indicators:

INDICATOR	COLOUR CHANGE	COLOUR CHANGE pH RANGE
Methyl orange	Red – Yellow	3,0 – 4,4
Bromothymol blue	Yellow – blue	6,0 – 7,6
Phenolphthalein	Colourless - pink	8,2 – 9,8

7.4.3 Use the information in the table above and choose a suitable indicator to use in the above titration. Give a reason for the answer. (2)

7.4.4 The ethanoate ions that form during the reaction, react with water according to the balanced equation below:



Write down the name of the process described by the underlined phrase.

(1)
[19]

QUESTION 8 (Start on a new page)

The two half-cells, $\text{Fe}(s) | \text{Fe}^{2+}(\text{aq})$ and $\text{O}_2(\text{g}) | \text{H}_2\text{O}(\text{l})$ in acid solution, are used to set up an electrochemical cell. The cell operates under standard conditions.

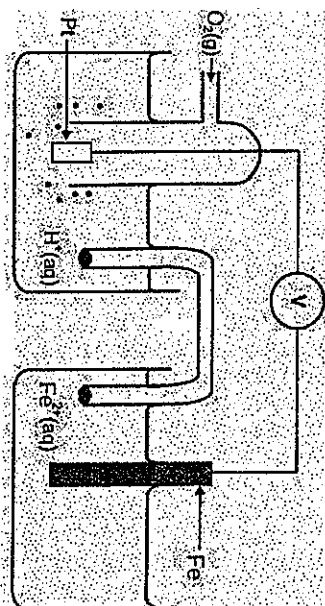

- 8.1 Write down TWO standard conditions, other than temperature, which apply to this electrochemical cell. (2)
- 8.2 Give TWO reasons, besides being a solid, why platinum is a suitable electrode in the above cell. (2)
- 8.3 Write down the half-reaction that takes place at the cathode of this cell. (2)
- 8.4 Write down the cell notation of this cell. (3)
- 8.5 Calculate the initial emf of this cell. (4)
- 8.6 The reading of the voltmeter becomes zero after using the cell for several hours. Give a reason for this reading by referring to the cell reaction. (1)

[14]

QUESTION 9 (start on a new page)

The diagram below show an electrolytic cell used to coat a nickel coin with silver.

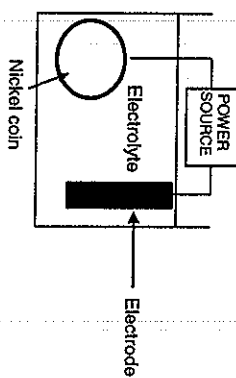

- 9.1 Which electrode (anode or cathode) does the nickel coin represent? (1)
- 9.2 Define the term *electrolyte*. (2)
- 9.3 Write down the NAME or FORMULA of a suitable electrolyte used in this cell. (1)
- 9.4 Write down the half-reaction that takes place on the surface of the nickel coin. (2)
- 9.5 How will the concentration of the electrolyte change during electrolysis? Choose from INCREASE, DECREASE or REMAINS THE SAME. (1)
- 9.6 Explain the answer in QUESTION 9.5. (2)

[9]

QUESTION 10 (Start on a new page)

The diagram below illustrates the processes used to manufacture a certain fertilizer. Study the diagram and answer the questions that follow.

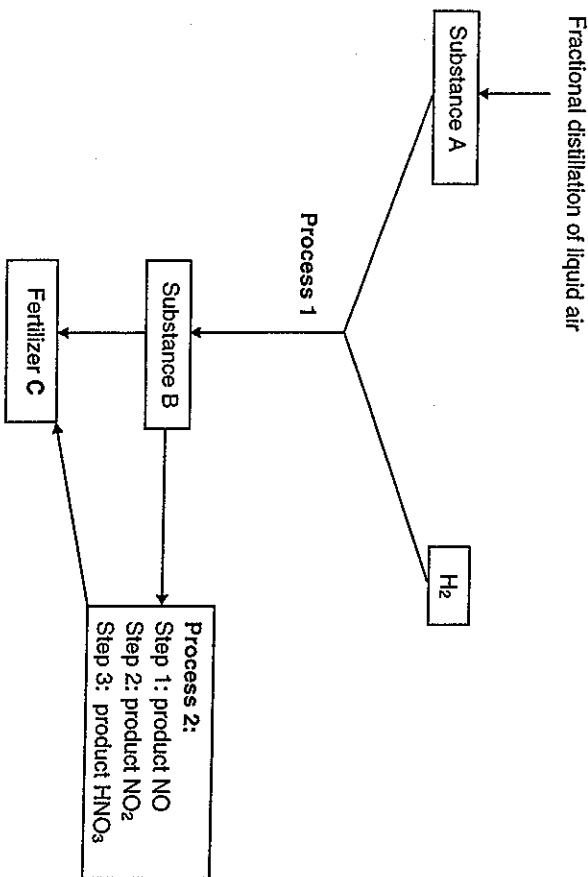

- 10.1.1 NAME or FORMULA of substance A that is obtained by the fractional distillation of liquid air. (1)
- 10.1.2 Balanced equation for the reaction that occurs in Process 1. (3)
- 10.1.3 NAME of the substance B that forms as a result of Process 1. (1)
- 10.1.4 NAME of process 2. (1)
- 10.1.5 NAME or FORMULA of fertiliser C. (1)
- 10.1.6 NAME of the process that occurs when excess fertiliser C runs into the rivers. (1)



10.2 A farmer has two bags of fertiliser marked A and B, as shown below.

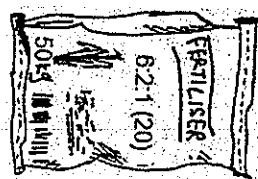
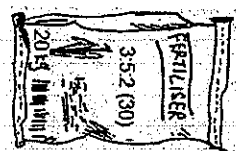

- 10.2.1 The farmer wants to grow tomatoes and fruits. Which ONE of these fertilisers must the farmer use, write down A or B. Give a reason for the answer. (2)
- 10.2.2 Calculate the mass of potassium in bag B. (4)

TOTAL MARKS: 150 [14]

DATA FOR PHYSICAL SCIENCES GRADE 12

PAPER 2 (CHEMISTRY)

GEWENS VIR FISESE WETenskappe GrAad 12
VRAESTEL 2 (CHEMIE)

TABLE 1: PHYSICAL CONSTANTS/TABEL 1: FISESEKONSTANTES

NAME/NAAM	SYMBOL/SIMBOOL	VALUE/WAARDE
Standard pressure Standarddruk	p^θ	1,013 x 10 ⁵ Pa
Molar gas volume at STP Molêre gasvolume by STD	V_m	22,4 dm ³ mol ⁻¹
Standard temperature Standaritemperatuur	T^θ	273 K
Charge on electron Lading op elektron	e	-1,6 x 10 ⁻¹⁹ C
Avogadro's constant Avogadro-konstante	N_A	6,02 x 10 ²³ mol ⁻¹

TABLE 2: FORMULAE/TABEL 2: FORMULES

$n = \frac{m}{M}$	$n = \frac{N}{N_A}$
$c = \frac{n}{V}$ or $c = \frac{m}{MV}$	$\eta = \frac{V}{V_m}$
$C_1V_1 = n_2$	pH = $-\log[H_3O^+]$
$K_w = [H_3O^+][OH^-] = 1 \times 10^{-14}$ at 298 K	
$E^\theta_{\text{oxidiserende agente}} - E^\theta_{\text{reducerende agente}} = E^\theta_{\text{span}}$	
or/of	
$E^\theta_{\text{reduction}} - E^\theta_{\text{oxidation}} = E^\theta_{\text{span}}$	
or/of	
$E^\theta_{\text{reducing agent}} - E^\theta_{\text{oxidising agent}} = E^\theta_{\text{span}}$	



TABLE 3: THE PERIODIC TABLE OF ELEMENTS
TABEL 3: DIE PERIODIEKE TABEL VAN ELEMENTE

KEY/SLEUTEL

Atomic number
Atoomgetal

Electronegativity
Elektronegatiwiteit

Symbol
Simbool

Approximate relative atomic mass
Benaderde relatiewe atoommassa

1 (I) 1,2 H	2 (II) 4 He	3 7 Li	4 9 Be	5	6	7	8	9	10	11	12	13 (III) 5 B	14 (IV) 6 C	15 (V) 7 N	16 (VI) 8 O	17 (VII) 9 F	18 (VIII) 10 Ne																	
11 6,9 Na	12 24 Mg	19 39 K	20 40 Ca	21 45 Sc	22 48 Ti	23 51 V	24 52 Cr	25 55 Mn	26 56 Fe	27 59 Co	28 59 Ni	29 63,5 Cu	30 65 Zn	31 70 Ga	32 73 Ge	33 75 As	34 79 Se	35 80 Br	36 84 Kr															
37 86 Rb	38 88 Sr	39 89 Y	40 91 Zr	41 92 Nb	42 96 Mo	43 98 Tc	44 101 Ru	45 103 Rh	46 106 Pd	47 108 Ag	48 112 Cd	49 112 In	50 115 Sn	51 122 Sb	52 128 Te	53 127 I	54 131 Xe	55 133 Cs	56 137 Ba	57 139 La	58 140 Ce	59 141 Pr	60 144 Nd	61 150 Pm	62 150 Sm	63 152 Eu	64 157 Gd	65 159 Tb	66 163 Dy	67 165 Ho	68 167 Er	69 169 Tm	70 173 Yb	71 175 Lu
87 7,0 Fr	88 7,0 Ra	89 Ac	72 179 Hf	73 181 Ta	74 184 W	75 186 Re	76 190 Os	77 192 Ir	78 195 Pt	79 197 Au	80 201 Hg	81 204 Tl	82 207 Pb	83 209 Bi	84 209 Po	85 210 At	86 210 Rn	91 232 Th	92 238 U	93 Np	94 Pu	95 Am	96 Cm	97 Bk	98 Cf	99 Es	100 Fm	101 Md	102 No	103 Lr				

TABLE 4A: STANDARD REDUCTION POTENTIALS
TABEL 4A: STANDAARD-REDUKSIEPOTENSIALE

Half-reactions/Halfreaksies	E° (V)
$F_2(g) + 2e^- \rightleftharpoons 2F^-$	+2,87
$Co^{3+} + e^- \rightleftharpoons Co^{2+}$	+1,81
$H_2O + 2H^+ + 2e^- \rightleftharpoons 2H_2O$	+1,77
$MnO_4^- + 8H^+ + 5e^- \rightleftharpoons Mn^{2+} + 4H_2O$	+1,51
$Cr_2O_7^{2-} + 2e^- \rightleftharpoons 2Cr^{3+} + 7H_2O$	+1,36
$O_2(g) + 4H^+ + 4e^- \rightleftharpoons 2H_2O$	+1,23
$MnO_2 + 4H^+ + 2e^- \rightleftharpoons Mn^{2+} + 2H_2O$	+1,23
$Pb^{2+} + 2e^- \rightleftharpoons Pb$	+1,20
$Br_2(l) + 2e^- \rightleftharpoons 2Br^-$	+1,07
$NO_3^- + 4H^+ + 3e^- \rightleftharpoons NO(g) + 2H_2O$	+0,96
$Hg^{2+} + 2e^- \rightleftharpoons Hg(l)$	+0,85
$Ag^+ + e^- \rightleftharpoons Ag$	+0,80
$NO_3^- + 2H^+ + e^- \rightleftharpoons NO_2(g) + H_2O$	+0,80
$Fe^{3+} + e^- \rightleftharpoons Fe^{2+}$	+0,77
$O_2(g) + 2H^+ + 2e^- \rightleftharpoons H_2O_2$	+0,69
$I_2 + 2e^- \rightleftharpoons 2I^-$	+0,54
$Cu^{2+} + 2e^- \rightleftharpoons Cu$	+0,52
$SO_4^{2-} + 4H^+ + 4e^- \rightleftharpoons S + 2H_2O$	+0,45
$2H_2O + O_2 + 4e^- \rightleftharpoons 4OH^-$	+0,40
$Cu^+ + e^- \rightleftharpoons Cu$	+0,34
$SO_4^{2-} + 4H^+ + 2e^- \rightleftharpoons SO_2(g) + 2H_2O$	+0,17
$Cu^{2+} + e^- \rightleftharpoons Cu^+$	+0,16
$Sn^{2+} + 2e^- \rightleftharpoons Sn$	+0,16
$S + 2H^+ + 2e^- \rightleftharpoons H_2S(g)$	+0,14
$2H^+ + 2e^- \rightleftharpoons H_2(g)$	0,00
$Pb^{2+} + 2e^- \rightleftharpoons Pb$	-0,06
$Sr^{2+} + 2e^- \rightleftharpoons Sr$	-0,13
$Ni^{2+} + 2e^- \rightleftharpoons Ni$	-0,14
$Co^{2+} + 2e^- \rightleftharpoons Co$	-0,27
$Cd^{2+} + 2e^- \rightleftharpoons Cd$	-0,28
$Cl_2 + e^- \rightleftharpoons Cl_2^-$	-0,40
$Fe^{3+} + 2e^- \rightleftharpoons Fe$	-0,41
$Cl_2 + 3e^- \rightleftharpoons Cl^-$	-0,44
$Cl_2 + 3e^- \rightleftharpoons Cl^-$	-0,74
$Zn^{2+} + 2e^- \rightleftharpoons Zn$	-0,76
$2H_2O + 2e^- \rightleftharpoons H_2(g) + 2OH^-$	-0,83
$Cr^{3+} + 2e^- \rightleftharpoons Cr$	-0,91
$Mn^{2+} + 2e^- \rightleftharpoons Mn$	-1,18
$Al^{3+} + 3e^- \rightleftharpoons Al$	-1,66
$Mg^{2+} + 2e^- \rightleftharpoons Mg$	-2,36
$Na^+ + e^- \rightleftharpoons Na$	-2,71
$Ca^{2+} + 2e^- \rightleftharpoons Ca$	-2,87
$Sr^{2+} + 2e^- \rightleftharpoons Sr$	-2,89
$Ba^{2+} + 2e^- \rightleftharpoons Ba$	-2,90
$Cs^+ + e^- \rightleftharpoons Cs$	-2,92
$K^+ + e^- \rightleftharpoons K$	-2,93
$Li^+ + e^- \rightleftharpoons Li$	-3,05

Increasing oxidising ability/Toenemende oksiderende vermoë

Increasing reducing ability/Toenemende reduserende vermoë

TABLE 4B: STANDARD REDUCTION POTENTIALS
TABEL 4B: STANDAARD-REDUKSIEPOTENSIALE

Half-reactions/Halfreaksies	E° (V)
$Li^+ + e^- \rightleftharpoons Li$	-3,05
$K^+ + e^- \rightleftharpoons K$	-2,93
$Cs^+ + e^- \rightleftharpoons Cs$	-2,92
$Ba^{2+} + 2e^- \rightleftharpoons Ba$	-2,90
$Sr^{2+} + 2e^- \rightleftharpoons Sr$	-2,89
$Ca^{2+} + 2e^- \rightleftharpoons Ca$	-2,87
$Na^+ + e^- \rightleftharpoons Na$	-2,71
$Mg^{2+} + 2e^- \rightleftharpoons Mg$	-2,36
$Al^{3+} + 3e^- \rightleftharpoons Al$	-1,66
$Mn^{2+} + 2e^- \rightleftharpoons Mn$	-1,18
$Cr^{2+} + 2e^- \rightleftharpoons Cr$	-0,91
$2H_2O + 2e^- \rightleftharpoons H_2(g) + 2OH^-$	-0,83
$Zn^{2+} + 2e^- \rightleftharpoons Zn$	-0,76
$Cr^{3+} + 3e^- \rightleftharpoons Cr$	-0,74
$Fe^{2+} + 2e^- \rightleftharpoons Fe$	-0,44
$O_2 + 2e^- \rightleftharpoons O_2^{2-}$	-0,41
$Cd^{2+} + 2e^- \rightleftharpoons Cd$	-0,40
$Co^{2+} + 2e^- \rightleftharpoons Co$	-0,28
$Ni^{2+} + 2e^- \rightleftharpoons Ni$	-0,27
$Sn^{2+} + 2e^- \rightleftharpoons Sn$	-0,14
$Pb^{2+} + 2e^- \rightleftharpoons Pb$	-0,13
$Fe^{3+} + 3e^- \rightleftharpoons Fe$	-0,06
$2H^+ + 2e^- \rightleftharpoons H_2(g)$	0,00
$S + 2H^+ + 2e^- \rightleftharpoons H_2S(g)$	+0,14
$Sn^{2+} + 2e^- \rightleftharpoons Sn$	+0,15
$Cu^+ + e^- \rightleftharpoons Cu$	+0,16
$SO_2 + 4H^+ + 2e^- \rightleftharpoons SO_2(g) + 2H_2O$	+0,17
$Cu^{2+} + 2e^- \rightleftharpoons Cu$	+0,34
$2H_2O + O_2 + 4e^- \rightleftharpoons 4OH^-$	+0,40
$SO_2 + 4H^+ + 4e^- \rightleftharpoons S + 2H_2O$	+0,45
$Cu^+ + e^- \rightleftharpoons Cu$	+0,52
$I_2 + 2e^- \rightleftharpoons 2I^-$	+0,54
$O_2(g) + 2H^+ + 2e^- \rightleftharpoons H_2O_2$	+0,68
$Fe^{3+} + e^- \rightleftharpoons Fe^{2+}$	+0,77
$NO_3^- + 2H^+ + e^- \rightleftharpoons NO_2(g) + H_2O$	+0,80
$Ag^+ + e^- \rightleftharpoons Ag$	+0,80
$Hg^{2+} + 2e^- \rightleftharpoons Hg(l)$	+0,85
$NO_3^- + 4H^+ + 3e^- \rightleftharpoons NO(g) + 2H_2O$	+0,96
$Br_2(l) + 2e^- \rightleftharpoons 2Br^-$	+1,07
$Pt^{2+} + 2e^- \rightleftharpoons Pt$	+1,20
$MnO_2 + 4H^+ + 2e^- \rightleftharpoons Mn^{2+} + 2H_2O$	+1,23
$O_2(g) + 4H^+ + 4e^- \rightleftharpoons 2H_2O$	+1,23
$Cr_2O_7^{2-} + 14H^+ + 6e^- \rightleftharpoons 2Cr^{3+} + 7H_2O$	+1,33
$Cl_2(g) + 2e^- \rightleftharpoons 2Cl^-$	+1,36
$MnO_4^- + 8H^+ + 5e^- \rightleftharpoons Mn^{2+} + 4H_2O$	+1,51
$H_2O_2 + 2H^+ + 2e^- \rightleftharpoons 2H_2O$	+1,77
$Co^{3+} + e^- \rightleftharpoons Co^{2+}$	+1,81
$F_2(g) + 2e^- \rightleftharpoons 2F^-$	+2,87

Increasing oxidising ability/Toenemende oksiderende vermoë

Increasing reducing ability/Toenemende reduserende vermoë