



education

Department:
Education
PROVINCE OF KWAZULU-NATAL

**NATIONAL
SENIOR CERTIFICATE**

GRADE 12

PHYSICAL SCIENCES P2 (CHEMISTRY)

PREPARATORY EXAMINATION

SEPTEMBER 2019

MARKS : 150

TIME : 3 Hours

This question paper consists of 14 pages, a special answer sheet and 4 data sheets.

INSTRUCTIONS AND INFORMATION

1. Write your centre number and examination number in the appropriate spaces on the ANSWER BOOK.
2. This question paper consists of TEN questions. Answer ALL the questions in the ANSWER BOOK.
3. Start EACH question on a NEW page in the ANSWER BOOK.
4. Number the answers correctly according to the numbering system used in this question paper.
5. Leave ONE line between two subquestions, for example between QUESTION 2.1 and QUESTION 2.2.
6. You may use a non-programmable calculator.
7. You may use appropriate mathematical instruments.
8. You are advised to use the attached DATA SHEETS.
9. Show ALL formulae and substitutions in ALL calculations.
10. Round off your final numerical answers to a minimum of TWO decimal places.
11. Give brief motivations, discussions et cetera where required.
12. Write neatly and legibly.

QUESTION 1: MULTIPLE-CHOICE QUESTIONS

Various options are provided as possible answers to the following questions. Choose the answer and write only the letter (A-D) next to the question number (1.1-1.10) in the ANSWER BOOK, for example 1.11 D.

- 1.1 Which ONE of the following organic reactions below involves the bonding of monomers by a dehydration process?
- A Halogenation.
 - B Dehydropolymerisation.
 - C Addition polymerisation.
 - D Condensation polymerisation. (2)
- 1.2 A compound with the molecular formula $C_5H_{10}O$ could be . . .
- (I) an ester.
 - (II) a ketone.
 - (III) an aldehyde.
- A (I) only.
 - B (I) and (II) only
 - C (II) and (III) only
 - D (I), (II) and (III) (2)
- 1.3 A catalyst will change the . . .
- A time required to reach equilibrium.
 - B amount of products present at equilibrium.
 - C amount of reactants present at equilibrium.
 - D length time for a reaction remains at equilibrium. (2)
- 1.4 The difference between the potential energy of the products and the potential energy of the reactants in a chemical reaction is equal to the . . .
- A rate of the reaction.
 - B enthalpy of the reaction.
 - C enthalpy change of the reaction.
 - D total potential energy of the particles. (2)

1.5 Which ONE of the following represents the products formed during the hydrolysis of sodium ethanoate, NaCH_3COO ?

- A $\text{Na}^+(\text{aq})$ and $\text{OH}^-(\text{aq})$
- B $\text{Na}^+(\text{aq})$ and $\text{CH}_3\text{COO}^-(\text{aq})$
- C $\text{H}_3\text{O}^+(\text{aq})$ and $\text{CH}_3\text{COO}^-(\text{aq})$
- D $\text{CH}_3\text{COOH}(\text{aq})$ and $\text{OH}^-(\text{aq})$

(2)

1.6 The reaction, $\text{H}_2(\text{g}) + \text{I}_2(\text{g}) \rightleftharpoons 2\text{HI}(\text{g})$, $\Delta H < 0$, reaches equilibrium at a temperature of $445\text{ }^\circ\text{C}$ in a sealed container.

Which ONE of the following change/s will INCREASE the CONCENTRATION of $\text{HI}(\text{g})$?

- I adding a catalyst
- II decreasing the temperature
- III increasing the pressure by reducing the volume of the reaction container

- A only II
- B only III
- C I and II only
- D II and III only

(2)

- 1.7 Learners set up an electrochemical cell, shown in the simplified diagram below, using magnesium and lead electrodes.

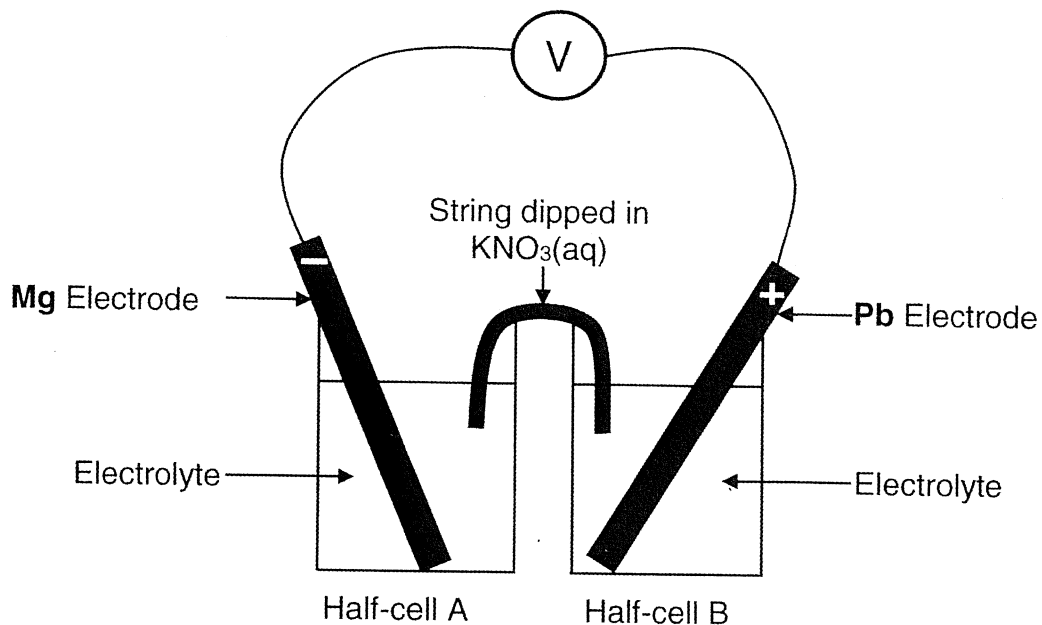

Which of the following changes will INCREASE the reading on the voltmeter?

- (i) Decreasing the initial concentration of the electrolyte in half-cell A.
- (ii) Decreasing the initial concentration of the electrolyte in half-cell B.
- (iii) Increasing the initial concentration of the electrolyte in half-cell A.
- (iv) Increasing the initial concentration of the electrolyte in half-cell B.

- A (i) Only
- B (ii) only
- C (ii) and (iii) only
- D (i) and (iv) only

(2)

- 1.8 The balanced equation for the net(overall) cell reaction that occurs during the electrolysis of a concentrated sodium chloride solution is :

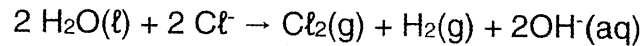

Which ONE of the following statements concerning the above electrolysis is TRUE?

- A The reaction is exothermic.
- B The reaction is spontaneous.
- C chlorine gas is formed at the anode.
- D hydrogen gas is formed at the anode. (2)

- 1.9 Which ONE of the following reactions DOES NOT occur during the Contact Process?

- A $\text{S} + \text{O}_2 \rightarrow \text{SO}_2$
- B $2 \text{SO}_2 + \text{O}_2 \rightarrow 2 \text{SO}_3$
- C $\text{SO}_3 + \text{H}_2\text{O} \rightarrow \text{H}_2\text{SO}_4$
- D $\text{SO}_3 + \text{H}_2\text{SO}_4 \rightarrow \text{H}_2\text{S}_2\text{O}_7$ (2)

- 1.10 Phosphorous rich fertiliser . . .

- A improves the quality of fruit and flowers.
 - B is used to stimulate root growth in plants.
 - C is produced industrially by the Ostwald process.
 - D is essential for growing plants with strong stems and healthy green leaves. (2)
- [20]

QUESTION 2 (Start on a new page.)

The letters A to G in the table below represent seven organic compounds.

A	propanoic acid	B	$\text{CH}_3\text{CH}_2\text{CH}_2\text{COCH}_2\text{CH}_3$
C	$ \begin{array}{ccccccc} & \text{H} & & \text{O} & & \text{H} & \\ & & & & & & \\ \text{H} & - \text{C} & - \text{O} & - \text{C} & - & \text{C} & - \text{H} \\ & & & & & & \\ \text{H} & - \text{C} & - \text{H} & & \text{H} & - \text{C} & - \text{H} \\ & & & & & & \\ & \text{H} & & & & \text{H} & \end{array} $	D	$ \begin{array}{ccccccc} & & & \text{O} & & & \\ & & & & & & \\ \text{CH}_3 & - & \text{C} & - \text{O} & - & \text{CH}_2 & - \text{CH}_3 \end{array} $
E	$\text{CH}_3\text{CCCH}(\text{CH}_3)\text{CH}_3$	F	ethene
G	$\text{CH}_3(\text{CH}_2)_3\text{CH}_3$		

2.1 Using the information in the table, write down the:

2.1.1 IUPAC name of compound **B**. (2)

2.1.2 Name of the FUNCTIONAL GROUP of the homologous series to which compound **A** belongs. (1)

2.1.3 Structural formula of compound **E**. (2)

2.1.4 The type of polymerisation where **F** is the monomer. (1)

2.1.5 IUPAC name and structural formula of the polymer formed from compound **F**. (3)

2.1.6 Letter that represents a compound that is a chain isomer of 2,2 – dimethylpropane. (1)

2.2 Compound **C**, in the table is the product of the reaction between an alcohol and a carboxylic acid in the presence of concentrated sulphuric acid.

Write down the:

2.2.1 Homologous series to which compound **C** belongs. (1)

2.2.2 IUPAC name of compound **C**. (2)

2.2.3 Structural formula of the carboxylic acid required to prepare compound **C**. (2)

2.2.4 Function of concentrated sulphuric acid in the above reaction. (1)

2.3 Compound C, in the table, has isomers.

2.3.1 Define the term *functional isomer*.

(2)

2.3.2 Write down the IUPAC name of the straight chain functional isomer of compound C.

(2)

[20]

QUESTION 3 (Start on a new page.)

Consider the organic compounds represented by the letters **M** and **N** below:

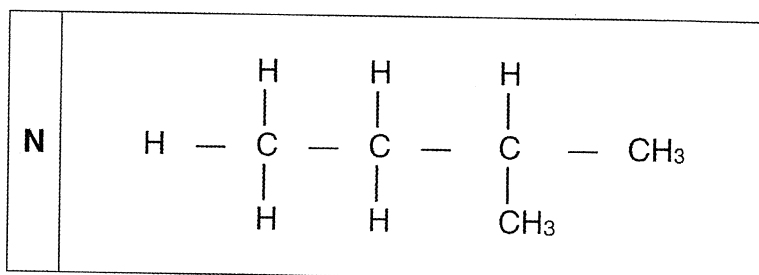
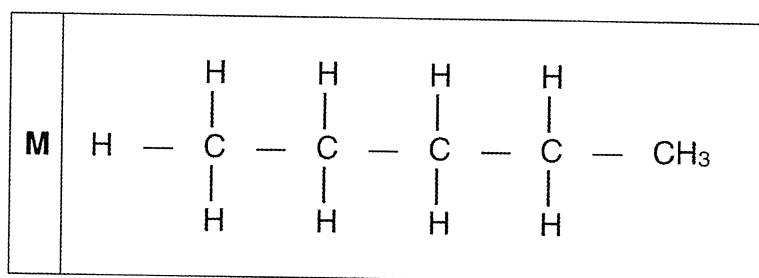

An investigation is performed to determine which compound; **M** or **N** has a higher vapour pressure.

3.1 Define *vapour pressure*.

(2)

3.2 For this investigation write down:

3.2.1 The independent variable.

(1)

3.2.2 A controlled variable.

(1)

3.3 This investigation is carried out at an atmospheric pressure of 100 kPa.

The temperature at which the vapour pressure of compound N equals 100 kPa is 27,80 °C.

3.3.1 At a temperature, **T**, the vapour pressure of compound **M** equals 100 kPa. Is **T**, GREATER THAN, EQUAL TO or LESS THAN 27,80 °C? (1)

3.3.2 Refer to structure, intermolecular forces and energy to explain the answer to QUESTION 3.3.1. (3)

3.4 Which compound **M** or **N** has the HIGHER vapour pressure? (1)
[9]

QUESTION 4 (Start on a new page.)

REACTION I and **REACTION II** below are organic reactions in which 2-bromobutane is reacted with solutions of KOH.

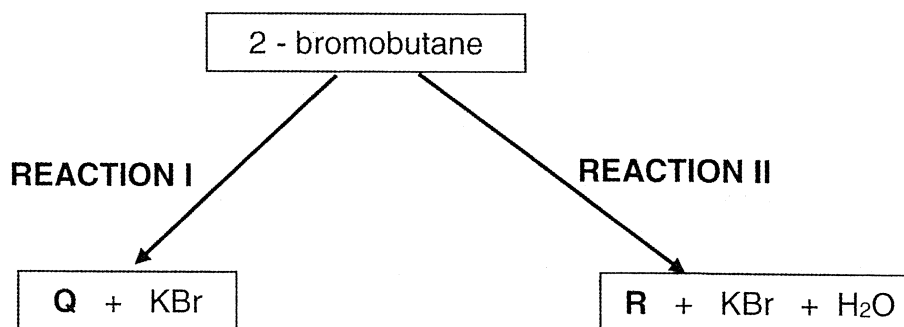

Q and **R** are the major organic products formed in **REACTION I** and **REACTION II** respectively.

Q and **R** represent different organic compounds.

4.1 State TWO reaction conditions for:

4.1.1 **REACTION I.** (2)

4.1.2 **REACTION II.** (2)

4.2 What type of reaction (SUBSTITUTION, ADDITION or ELIMINATION), takes place in **REACTION I**? (1)

4.3 Use structural formulae to write down a balanced equation for the reaction that takes place in **REACTION II.** (4)

4.4 Is **R** saturated or unsaturated? Give a reason for the answer. (3)

4.5 In a third reaction, **R** is converted to **Q**. Name the type of addition reaction that takes place during this conversion. (2)

[14]

QUESTION 5 (Start on a new page)

Powdered calcium carbonate reacts with hydrochloric acid according to the following balanced equation.



The mass of the CaCO_3 after every 10 s from the start of the reaction is indicated in the table below:

Time in seconds	0	10	20	30	40	50	60	70	80
Mass of CaCO_3 in grams	X	74	63	54	46	42	40	40	40

The initial mass of the CaCO_3 is X g.

- 5.1 According to the data in the table above, which substance, calcium carbonate or hydrochloric acid is in excess? Give a reason for the answer. (2)
- 5.2 The average rate of the reaction in the first 30 s is $1,07 \text{ g}\cdot\text{s}^{-1}$.
- 5.2.1 Define *reaction rate*, in words. (2)
- 5.2.2 Calculate the initial mass, X, of calcium carbonate. (5)
- 5.3 What volume of CO_2 is produced between 60 and 80 seconds? (1)
- 5.4 Use the collision theory to explain why the average rate of reaction between powdered calcium carbonate and the given hydrochloric acid solution decreases with time. (3)
- 5.5 How will the rate of the above reaction be affected if the initial mass of carbonate was doubled? (Only write down, INCREASES, DECREASES or REMAINS THE SAME) (1)
- [14]

QUESTION 6 (Start on a new page)

Study the reversible reaction represented by the balanced equation at a fixed temperature below:

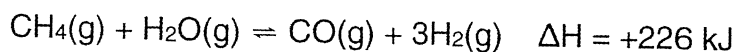

Initially, 2,2 moles of $\text{CH}_4(\text{g})$ and 1,8 moles of $\text{H}_2\text{O}(\text{g})$ were mixed in a sealed 2 dm^3 container.

The graph below shows the relationship between the number of moles of $\text{CO}(\text{g})$ and time in minutes.

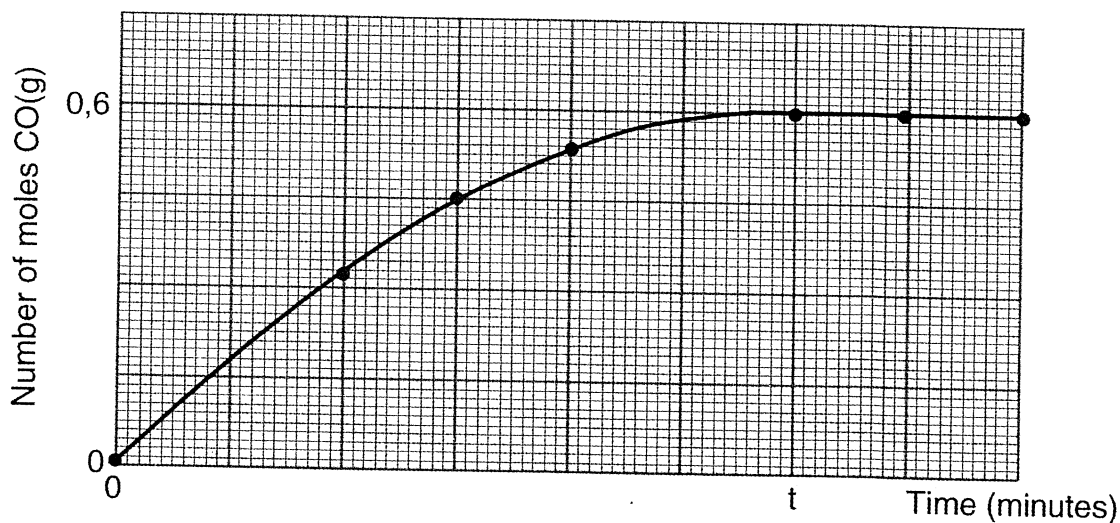

- 6.1 State Le Chatelier's Principle. (2)
- 6.2 What information about the reaction can be deduced from the graph after t minutes? (2)
- 6.3 Calculate the value of the equilibrium constant, K_c , at the fixed temperature used in the reaction. (7)
- 6.4 Draw a graph (not to scale), on the special answer sheet provided showing the changes in the number of moles of $\text{CH}_4(\text{g})$ as the reaction proceeds. Indicate the initial number of moles of $\text{CH}_4(\text{g})$ and the number of moles of $\text{CH}_4(\text{g})$ at equilibrium, on the graph. (4)
- 6.5 The initial number of moles of $\text{CH}_4(\text{g})$ is now doubled in the same 2 dm^3 container.
How will this change affect the following? (Choose from INCREASES, DECREASES or REMAINS THE SAME?)
- 6.5.1 The amount of $\text{H}_2(\text{g})$ at equilibrium. (1)
- 6.5.2 Value of the equilibrium constant(K_c). (1)
- 6.6 Explain the answer to QUESTION 6.5.1 by referring to Le Chatelier's Principle. (3)

[20]

QUESTION 7 (Start on a new page.)

7.1 A **dilute solution of sulphuric acid** has a concentration $0,012 \text{ mol.dm}^{-3}$

7.1.1 Define an acid according to Arrhenius theory. (2)

7.1.2 Is the above solution of sulphuric acid a strong or weak acid?
Explain the answer. (3)

7.2 A learner adds 24 cm^3 of a solution of sulphuric acid of concentration $0,25 \text{ mol.dm}^{-3}$ to an unknown volume, $X \text{ cm}^3$, of a solution of sodium hydroxide of concentration $0,15 \text{ mol.dm}^{-3}$. The balanced equation for the reaction is:

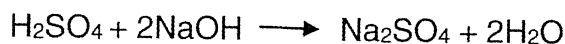

The pH of the resulting solution is 0,65.

7.2.1 Calculate the concentration of the sulphuric acid solution after it has reacted with the sodium hydroxide solution. (4)

7.2.2 Calculate the initial volume(X) of the sodium hydroxide solution. Assume that the volume of the solution after the reaction is $(X + 24) \text{ cm}^3$. (7)
[16]

QUESTION 8 (Start on a new page.)

A standard galvanic cell is set up using a zinc and an unknown metal, **X**. The graph below shows the change in mass of the metal, **X** whilst the cell is in operation.

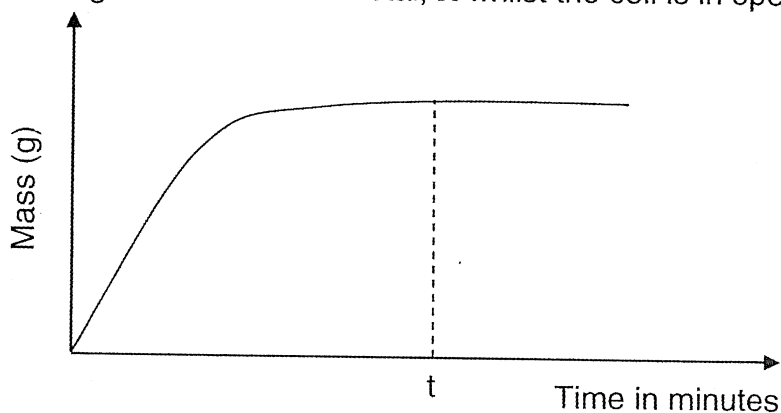

8.1 Define an electrolyte. (2)

8.2 Write down the half reaction that takes place at the anode of this cell. (2)

8.3 The initial emf of this cell under standard conditions is 0,63 V.

8.3.1 Write down TWO standard conditions required for the initial emf to be 0,63 V (2)

8.3.2 Identify the metal **X**, by calculating the standard reduction potential of **X**. (5)

8.4 Write down the cell notation for this cell. (3)

8.5 Write down the value of the emf at time **t**, shown on the graph. (1)

[15]

QUESTION 9 (Start on a new page.)

An electrolytic cell is set up using two carbon rods, P and Q and a concentrated copper(II) chloride solution as an electrolyte.

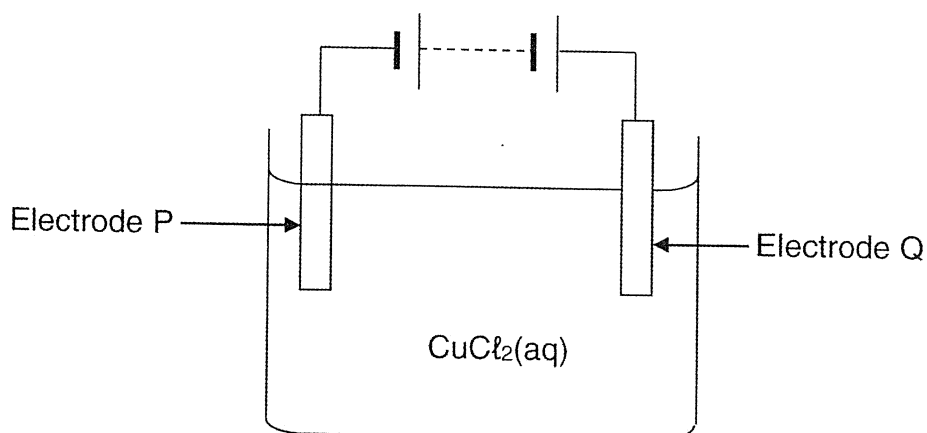

When the cell is functioning ONE of the carbon electrodes is coated with a reddish brown layer.

- 9.1 Write down the energy conversion that takes place in this cell. (1)
- 9.2 Which electrode, **P** or **Q** is coated with the reddish brown layer? (1)
- 9.3 Write down a half reaction that takes place at the electrode that is coated with the reddish brown layer. (2)
- 9.4 The carbon rods in the above cell are **NOW** replaced with copper rods.
- 9.4.1 Describe the observation that will be made at electrode **Q**. (2)
- 9.4.2 Refer to relative strengths of reducing agents to explain the observation made at electrode **Q**. (3)
- The cell can be used to electroplate a tin medal with a thin layer of copper.
- 9.4.3 Which electrode, **P** or **Q** must be replaced with the tin medal? (1)

[10]

QUESTION 10 (Start on a new page.)

10.1 The unbalanced equations below represent various steps in the Ostwald process.

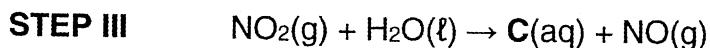
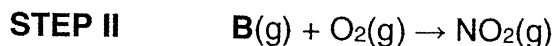
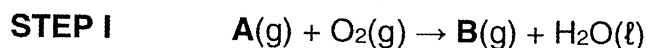

10.1.1 Write down the name of the industrial process that produces gas **A**. (1)

10.1.2 Write down the name or formula of gas **B**. (1)

10.1.3 Name the catalyst that is used in **STEP I**. (1)

The product, **C**, from **STEP III** mixes with reactant **A** from **STEP I** to produce a fertiliser.

10.1.4 Write a balanced equation to illustrate this reaction. (3)

10.2 Consider the fertiliser in the bag illustrated below:

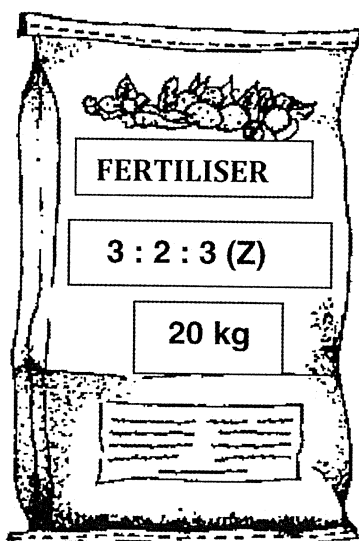

The only phosphorous containing compound used in the production of this fertiliser is $(NH_4)_3PO_4$

11,95 kg of $(NH_4)_3PO_4$ was used in preparing the fertiliser illustrated above.

Calculate the value represented by the letter **Z**, in the above illustration.

TOTAL MARKS:

(6)
[12]
150

SPECIAL ANSWER SHEET FOR QUESTION 6.4

NAME: _____ GRADE: _____

DETACH THIS ANSWER SHEET AND SUBMIT WITH YOUR ANSWER BOOKLET

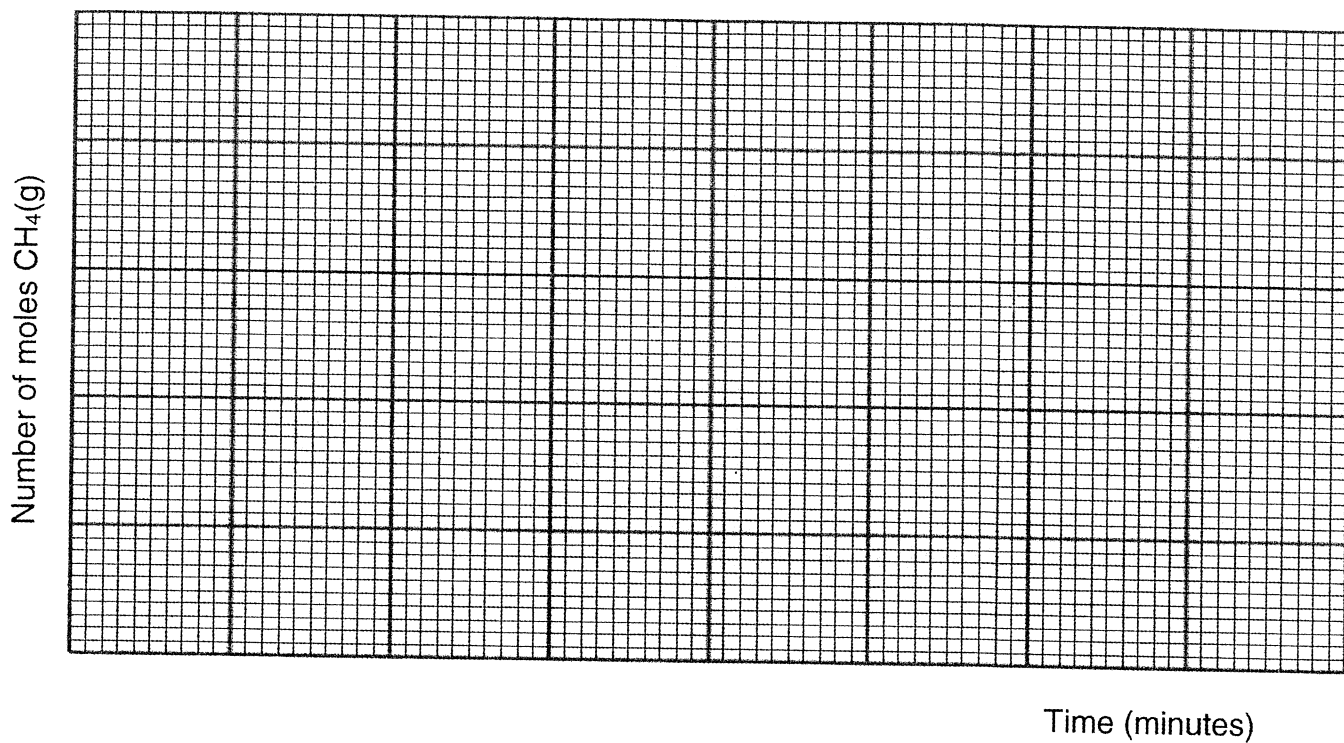

**DATA FOR PHYSICAL SCIENCES GRADE 12
PAPER 2 (CHEMISTRY)**

**GEGEWENS VIR FISIESTE WETENSKAPPE GRAAD 12
VRAESTEL 2 (CHEMIE)**

TABLE 1: PHYSICAL CONSTANTS/TABEL 1: FISIESTE KONSTANTES

NAME/NAAM	SYMBOL/SIMBOOL	VALUE/WAARDE
Standard pressure <i>Standaarddruk</i>	p^θ	$1,013 \times 10^5 \text{ Pa}$
Molar gas volume at STP <i>Molêre gasvolume by STD</i>	V_m	$22,4 \text{ dm}^3 \cdot \text{mol}^{-1}$
Standard temperature <i>Standaardtemperatuur</i>	T^θ	273 K
Charge on electron <i>Lading op elektron</i>	e	$-1,6 \times 10^{-19} \text{ C}$
Avogadro's constant <i>Avogadro-konstante</i>	N_A	$6,02 \times 10^{23} \text{ mol}^{-1}$

TABLE 2: FORMULAE/TABEL 2: FORMULES

$n = \frac{m}{M}$	$n = \frac{N}{N_A}$
$c = \frac{n}{V}$ or/of $c = \frac{m}{MV}$	$n = \frac{V}{V_m}$
$\frac{c_a v_a}{c_b v_b} = \frac{n_a}{n_b}$	$\text{pH} = -\log[\text{H}_3\text{O}^+]$
$K_w = [\text{H}_3\text{O}^+][\text{OH}^-] = 1 \times 10^{-14}$ at/by 298 K	
$E_{\text{cell}}^\theta = E_{\text{cathode}}^\theta - E_{\text{anode}}^\theta / E_{\text{sel}}^\theta = E_{\text{katode}}^\theta - E_{\text{anode}}^\theta$	
or/of $E_{\text{cell}}^\theta = E_{\text{reduction}}^\theta - E_{\text{oxidation}}^\theta / E_{\text{sel}}^\theta = E_{\text{reduksie}}^\theta - E_{\text{oksidasie}}^\theta$	
or/of $E_{\text{cell}}^\theta = E_{\text{oxidising agent}}^\theta - E_{\text{reducing agent}}^\theta / E_{\text{sel}}^\theta = E_{\text{oksideermiddel}}^\theta - E_{\text{reduseermiddel}}^\theta$	

TABLE 3: THE PERIODIC TABLE OF ELEMENTS

1	2	3	4	5	6	7	8	9	10	11	12	13 (III)	14 (IV)	15 (V)	16 (VI)	17 (VII)	18 (VIII)
1 H 2,1	2 (II)																2 He 4
3 Li 7	4 Be 9														8 O 16	9 F 19	10 Ne 20
11 Na 23	12 Mg 24														16 S 32	17 Cl 35,5	18 Ar 40
19 K 39	20 Ca 40	21 Sc 45	22 Ti 48	23 V 51	24 Cr 52	25 Mn 55	26 Fe 56	27 Co 59	28 Ni 59	29 Cu 63,5	30 Zn 65	31 Ga 70	32 Ge 73	33 As 75	34 Se 79	35 Br 80	36 Kr 84
37 Rb 86	38 Sr 88	39 Y 89	40 Zr 91	41 Nb 92	42 Mo 96	43 Tc 96	44 Ru 101	45 Rh 103	46 Pd 106	47 Ag 108	48 Cd 112	49 In 115	50 Sn 119	51 Sb 122	52 Te 128	53 I 127	54 Xe 131
55 Cs 133	56 Ba 137	57 La 139	72 Hf 179	73 Ta 181	74 W 184	75 Re 186	76 Os 190	77 Ir 192	78 Pt 195	79 Au 197	80 Hg 201	81 Tl 204	82 Pb 207	83 Bi 209	84 Po	85 At	86 Rn
87 Fr	88 Ra 226	89 Ac															

KEY/ISLEUTEL

Atomic number
Atoomgetal

Electronegativity
Elektronegatieweif

Symbol
Simbool

Approximate relative atomic mass
Benaderde relatiewe atoommassa

58 Ce 140	59 Pr 141	60 Nd 144	61 Pm	62 Sm 150	63 Eu 152	64 Gd 157	65 Tb 159	66 Dy 163	67 Ho 165	68 Er 167	69 Tm 169	70 Yb 173	71 Lu 175
90 Th 232	91 Pa	92 U 238	93 Np	94 Pu	95 Am	96 Cm	97 Bk	98 Cf	99 Es	100 Fm	101 Md	102 No	103 Lr

TABLE 4A: STANDARD REDUCTION POTENTIALS
TABEL 4A: STANDAARD-REDUKSIEPOTENSIALE

Half-reactions/Halfreaksies	E^θ (V)
$F_2(g) + 2e^- \rightleftharpoons 2F^-$	+ 2,87
$Co^{3+} + e^- \rightleftharpoons Co^{2+}$	+ 1,81
$H_2O_2 + 2H^+ + 2e^- \rightleftharpoons 2H_2O$	+1,77
$MnO_4^- + 8H^+ + 5e^- \rightleftharpoons Mn^{2+} + 4H_2O$	+ 1,51
$Cl_2(g) + 2e^- \rightleftharpoons 2Cl^-$	+ 1,36
$Cr_2O_7^{2-} + 14H^+ + 6e^- \rightleftharpoons 2Cr^{3+} + 7H_2O$	+ 1,33
$O_2(g) + 4H^+ + 4e^- \rightleftharpoons 2H_2O$	+ 1,23
$MnO_2 + 4H^+ + 2e^- \rightleftharpoons Mn^{2+} + 2H_2O$	+ 1,23
$Pt^{2+} + 2e^- \rightleftharpoons Pt$	+ 1,20
$Br_2(l) + 2e^- \rightleftharpoons 2Br^-$	+ 1,07
$NO_3^- + 4H^+ + 3e^- \rightleftharpoons NO(g) + 2H_2O$	+ 0,96
$Hg^{2+} + 2e^- \rightleftharpoons Hg(l)$	+ 0,85
$Ag^+ + e^- \rightleftharpoons Ag$	+ 0,80
$NO_3^- + 2H^+ + e^- \rightleftharpoons NO_2(g) + H_2O$	+ 0,80
$Fe^{3+} + e^- \rightleftharpoons Fe^{2+}$	+ 0,77
$O_2(g) + 2H^+ + 2e^- \rightleftharpoons H_2O_2$	+ 0,68
$I_2 + 2e^- \rightleftharpoons 2I^-$	+ 0,54
$Cu^+ + e^- \rightleftharpoons Cu$	+ 0,52
$SO_2 + 4H^+ + 4e^- \rightleftharpoons S + 2H_2O$	+ 0,45
$2H_2O + O_2 + 4e^- \rightleftharpoons 4OH^-$	+ 0,40
$Cu^{2+} + 2e^- \rightleftharpoons Cu$	+ 0,34
$SO_4^{2-} + 4H^+ + 2e^- \rightleftharpoons SO_2(g) + 2H_2O$	+ 0,17
$Cu^{2+} + e^- \rightleftharpoons Cu^+$	+ 0,16
$Sn^{4+} + 2e^- \rightleftharpoons Sn^{2+}$	+ 0,15
$S + 2H^+ + 2e^- \rightleftharpoons H_2S(g)$	+ 0,14
$2H^+ + 2e^- \rightleftharpoons H_2(g)$	0,00
$Fe^{3+} + 3e^- \rightleftharpoons Fe$	- 0,06
$Pb^{2+} + 2e^- \rightleftharpoons Pb$	- 0,13
$Sn^{2+} + 2e^- \rightleftharpoons Sn$	- 0,14
$Ni^{2+} + 2e^- \rightleftharpoons Ni$	- 0,27
$Co^{2+} + 2e^- \rightleftharpoons Co$	- 0,28
$Cd^{2+} + 2e^- \rightleftharpoons Cd$	- 0,40
$Cr^{3+} + e^- \rightleftharpoons Cr^{2+}$	- 0,41
$Fe^{2+} + 2e^- \rightleftharpoons Fe$	- 0,44
$Cr^{3+} + 3e^- \rightleftharpoons Cr$	- 0,74
$Zn^{2+} + 2e^- \rightleftharpoons Zn$	- 0,76
$2H_2O + 2e^- \rightleftharpoons H_2(g) + 2OH^-$	- 0,83
$Cr^{2+} + 2e^- \rightleftharpoons Cr$	- 0,91
$Mn^{2+} + 2e^- \rightleftharpoons Mn$	- 1,18
$Al^{3+} + 3e^- \rightleftharpoons Al$	- 1,66
$Mg^{2+} + 2e^- \rightleftharpoons Mg$	- 2,36
$Na^+ + e^- \rightleftharpoons Na$	- 2,71
$Ca^{2+} + 2e^- \rightleftharpoons Ca$	- 2,87
$Sr^{2+} + 2e^- \rightleftharpoons Sr$	- 2,89
$Ba^{2+} + 2e^- \rightleftharpoons Ba$	- 2,90
$Cs^+ + e^- \rightleftharpoons Cs$	- 2,92
$K^+ + e^- \rightleftharpoons K$	- 2,93
$Li^+ + e^- \rightleftharpoons Li$	- 3,05

Increasing oxidising ability/Toenemende oksiderende vermoë

Increasing reducing ability/Toenemende reduserende vermoë

TABLE 4B: STANDARD REDUCTION POTENTIALS
TABEL 4B: STANDAARD-REDUKSIEPOTENSIALE

Increasing oxidising ability/Toenemende oksiderende vermoë

Half-reactions/Halfreaksies	E^θ (V)
$\text{Li}^+ + \text{e}^- \rightleftharpoons \text{Li}$	-3,05
$\text{K}^+ + \text{e}^- \rightleftharpoons \text{K}$	-2,93
$\text{Cs}^+ + \text{e}^- \rightleftharpoons \text{Cs}$	-2,92
$\text{Ba}^{2+} + 2\text{e}^- \rightleftharpoons \text{Ba}$	-2,90
$\text{Sr}^{2+} + 2\text{e}^- \rightleftharpoons \text{Sr}$	-2,89
$\text{Ca}^{2+} + 2\text{e}^- \rightleftharpoons \text{Ca}$	-2,87
$\text{Na}^+ + \text{e}^- \rightleftharpoons \text{Na}$	-2,71
$\text{Mg}^{2+} + 2\text{e}^- \rightleftharpoons \text{Mg}$	-2,36
$\text{Al}^{3+} + 3\text{e}^- \rightleftharpoons \text{Al}$	-1,66
$\text{Mn}^{2+} + 2\text{e}^- \rightleftharpoons \text{Mn}$	-1,18
$\text{Cr}^{2+} + 2\text{e}^- \rightleftharpoons \text{Cr}$	-0,91
$2\text{H}_2\text{O} + 2\text{e}^- \rightleftharpoons \text{H}_2(\text{g}) + 2\text{OH}^-$	-0,83
$\text{Zn}^{2+} + 2\text{e}^- \rightleftharpoons \text{Zn}$	-0,76
$\text{Cr}^{3+} + 3\text{e}^- \rightleftharpoons \text{Cr}$	-0,74
$\text{Fe}^{2+} + 2\text{e}^- \rightleftharpoons \text{Fe}$	-0,44
$\text{Cr}^{3+} + \text{e}^- \rightleftharpoons \text{Cr}^{2+}$	-0,41
$\text{Cd}^{2+} + 2\text{e}^- \rightleftharpoons \text{Cd}$	-0,40
$\text{Co}^{2+} + 2\text{e}^- \rightleftharpoons \text{Co}$	-0,28
$\text{Ni}^{2+} + 2\text{e}^- \rightleftharpoons \text{Ni}$	-0,27
$\text{Sn}^{2+} + 2\text{e}^- \rightleftharpoons \text{Sn}$	-0,14
$\text{Pb}^{2+} + 2\text{e}^- \rightleftharpoons \text{Pb}$	-0,13
$\text{Fe}^{3+} + 3\text{e}^- \rightleftharpoons \text{Fe}$	-0,06
$2\text{H}^+ + 2\text{e}^- \rightleftharpoons \text{H}_2(\text{g})$	0,00
$\text{S} + 2\text{H}^+ + 2\text{e}^- \rightleftharpoons \text{H}_2\text{S}(\text{g})$	+0,14
$\text{Sn}^{4+} + 2\text{e}^- \rightleftharpoons \text{Sn}^{2+}$	+0,15
$\text{Cu}^{2+} + \text{e}^- \rightleftharpoons \text{Cu}^+$	+0,16
$\text{SO}_4^{2-} + 4\text{H}^+ + 2\text{e}^- \rightleftharpoons \text{SO}_2(\text{g}) + 2\text{H}_2\text{O}$	+0,17
$\text{Cu}^{2+} + 2\text{e}^- \rightleftharpoons \text{Cu}$	+0,34
$2\text{H}_2\text{O} + \text{O}_2 + 4\text{e}^- \rightleftharpoons 4\text{OH}^-$	+0,40
$\text{SO}_2 + 4\text{H}^+ + 4\text{e}^- \rightleftharpoons \text{S} + 2\text{H}_2\text{O}$	+0,45
$\text{Cu}^+ + \text{e}^- \rightleftharpoons \text{Cu}$	+0,52
$\text{I}_2 + 2\text{e}^- \rightleftharpoons 2\text{I}^-$	+0,54
$\text{O}_2(\text{g}) + 2\text{H}^+ + 2\text{e}^- \rightleftharpoons \text{H}_2\text{O}_2$	+0,68
$\text{Fe}^{3+} + \text{e}^- \rightleftharpoons \text{Fe}^{2+}$	+0,77
$\text{NO}_3^- + 2\text{H}^+ + \text{e}^- \rightleftharpoons \text{NO}_2(\text{g}) + \text{H}_2\text{O}$	+0,80
$\text{Ag}^+ + \text{e}^- \rightleftharpoons \text{Ag}$	+0,80
$\text{Hg}^{2+} + 2\text{e}^- \rightleftharpoons \text{Hg}(\ell)$	+0,85
$\text{NO}_3^- + 4\text{H}^+ + 3\text{e}^- \rightleftharpoons \text{NO}(\text{g}) + 2\text{H}_2\text{O}$	+0,96
$\text{Br}_2(\ell) + 2\text{e}^- \rightleftharpoons 2\text{Br}^-$	+1,07
$\text{Pt}^{2+} + 2\text{e}^- \rightleftharpoons \text{Pt}$	+1,20
$\text{MnO}_2 + 4\text{H}^+ + 2\text{e}^- \rightleftharpoons \text{Mn}^{2+} + 2\text{H}_2\text{O}$	+1,23
$\text{O}_2(\text{g}) + 4\text{H}^+ + 4\text{e}^- \rightleftharpoons 2\text{H}_2\text{O}$	+1,23
$\text{Cr}_2\text{O}_7^{2-} + 14\text{H}^+ + 6\text{e}^- \rightleftharpoons 2\text{Cr}^{3+} + 7\text{H}_2\text{O}$	+1,33
$\text{Cl}_2(\text{g}) + 2\text{e}^- \rightleftharpoons 2\text{Cl}^-$	+1,36
$\text{MnO}_4^- + 8\text{H}^+ + 5\text{e}^- \rightleftharpoons \text{Mn}^{2+} + 4\text{H}_2\text{O}$	+1,51
$\text{H}_2\text{O}_2 + 2\text{H}^+ + 2\text{e}^- \rightleftharpoons 2\text{H}_2\text{O}$	+1,77
$\text{Co}^{3+} + \text{e}^- \rightleftharpoons \text{Co}^{2+}$	+1,81
$\text{F}_2(\text{g}) + 2\text{e}^- \rightleftharpoons 2\text{F}^-$	+2,87

Increasing reducing ability/Toenemende reduserende vermoë