



# **basic education**

---

Department:  
Basic Education  
**REPUBLIC OF SOUTH AFRICA**

## **SENIOR CERTIFICATE EXAMINATIONS/ NATIONAL SENIOR CERTIFICATE EXAMINATIONS**

**PHYSICAL SCIENCES: PHYSICS (P1)**

**2019**

**MARKS: 150**

**TIME: 3 hours**

**This question paper consists of 16 pages and 3 data sheets.**



**INSTRUCTIONS AND INFORMATION**

1. Write your examination number and centre number in the appropriate spaces on the ANSWER BOOK.
2. This question paper consists of TEN questions. Answer ALL the questions in the ANSWER BOOK.
3. Start EACH question on a NEW page in the ANSWER BOOK.
4. Number the answers correctly according to the numbering system used in this question paper.
5. Leave ONE line between two subquestions, e.g. between QUESTION 2.1 and QUESTION 2.2.
6. You may use a non-programmable calculator.
7. You may use appropriate mathematical instruments.
8. Show ALL formulae and substitutions in ALL calculations.
9. Round off your FINAL numerical answers to a minimum of TWO decimal places.
10. Give brief motivations, discussions, etc. where required.
11. You are advised to use the attached DATA SHEETS.
12. Write neatly and legibly.



**QUESTION 1: MULTIPLE-CHOICE QUESTIONS**

Various options are provided as possible answers to the following questions. Choose the answer and write only the letter (A–D) next to the question numbers (1.1 to 1.10) in the ANSWER BOOK, e.g. 1.11 D.

1.1 A car is moving at a **constant velocity**.

Which ONE of the following statements about the forces acting on the car is CORRECT?

- A The net force acting on the car is zero.
- B There are no forces acting on the car.
- C The weight of the car is equal to the normal force acting on the car.
- D There is a non-zero net force acting on the car. (2)

1.2 A ball is projected vertically upwards. Ignore air resistance.

Which ONE of the following statements about the acceleration of the ball at its maximum height is CORRECT?

The acceleration is equal to ...

- A zero.
- B  $g$  and is directed downwards.
- C  $g$  and is directed upwards.
- D  $g$  and is directed horizontally. (2)



- 1.3 The graph below, not drawn to scale, shows the relationship between the gravitational force on a given mass and its distance from the centre of Earth.

The magnitude of the force on the mass at a distance  $R$  from the centre of Earth is  $F$ .

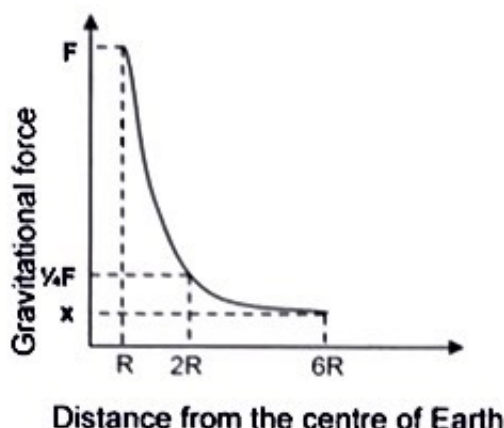

Which ONE of the following is the CORRECT representation of the magnitude of force  $x$  shown on the graph?

- A  $6F$
  - B  $12F$
  - C  $\frac{1}{6}F$
  - D  $\frac{1}{36}F$
- (2)
- 1.4 Ball M, moving at speed  $v$  to the right, collides with a stationary ball N on a smooth horizontal surface. Immediately after the collision, ball M comes to rest and ball N moves to the right with speed  $v$ .

Which ONE of the following statements about the collision of the balls is CORRECT?

- A Total momentum is conserved and the masses of the balls are unequal.
  - B Total kinetic energy is conserved and the masses of the balls are unequal
  - C Total momentum and total kinetic energy are conserved and the masses of the balls are equal.
  - D Total momentum is conserved but total kinetic energy is not conserved and the masses of the balls are equal.
- (2)



- 1.5 A small stone is dropped from rest and undergoes free fall.

Which ONE of the graphs below shows the CORRECT relationship between the gravitational potential energy ( $U$ ) and speed  $v$  and the kinetic energy ( $K$ ) and speed  $v$ , respectively, for the stone? The graphs are NOT drawn to scale.

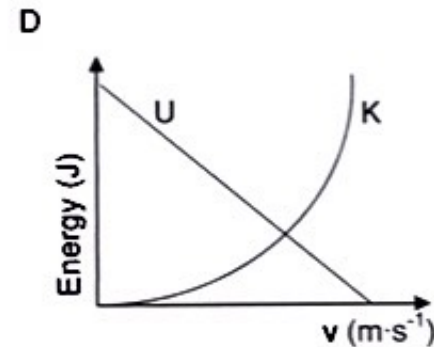
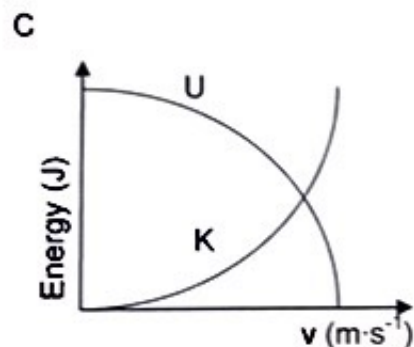
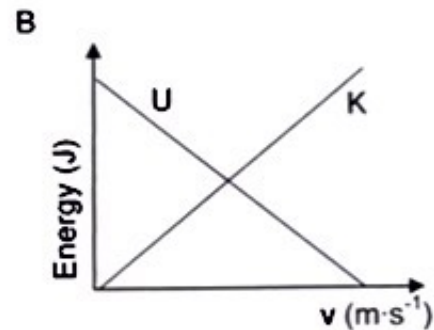
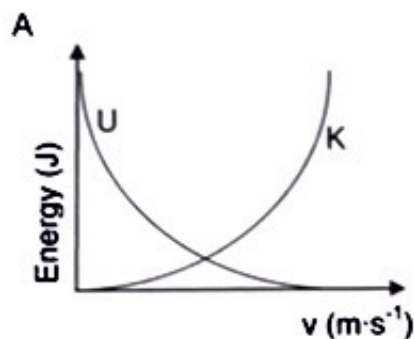

(2)

- 1.6 A stationary passenger at a railway station listens to a train approaching at constant speed.

Which ONE of the following is CORRECT for the sound of the approaching train heard by the stationary passenger?

- A Lower pitch, lower frequency
- B Higher pitch, lower frequency
- C Higher pitch, higher frequency
- D Lower pitch, higher frequency

(2)



- 1.7 Particle P has charge  $Q$  and particle R has charge  $2Q$ . They are separated by a small distance,  $r$ .

Which ONE of the statements below about the electrostatic forces,  $F_{PR}$ , which P exerts on R and  $F_{RP}$ , which R exerts on P, is CORRECT?

- A  $F_{PR} = \frac{1}{2}F_{RP}$
- B  $F_{PR} = F_{RP}$
- C  $F_{PR} = 2F_{RP}$
- D  $F_{PR} = -F_{RP}$  (2)

- 1.8 A battery of emf  $\mathcal{E}$  and negligible internal resistance is connected in a circuit, as shown below. The resistances of  $R_1$  and  $R_2$  are high.

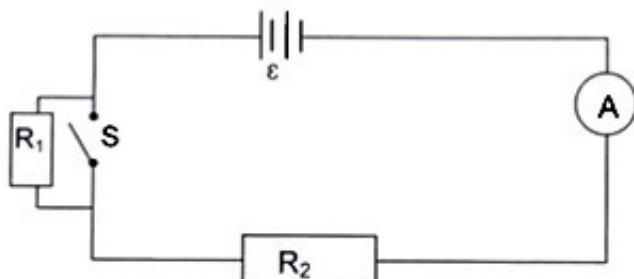

Which ONE of the following combinations about the ammeter readings will be CORRECT when switch S is open and when switch S is closed?

	SWITCH OPEN	SWITCH CLOSED
A	Ammeter reads only the current in $R_1$	Ammeter reads only the current in $R_2$
B	Ammeter reads only the current in $R_2$	Ammeter reads the current in both $R_1$ and $R_2$
C	Ammeter reads the current in both $R_1$ and $R_2$	Ammeter reads the current in both $R_1$ and $R_2$
D	Ammeter reads the current in both $R_1$ and $R_2$	Ammeter reads the current in $R_2$ only

(2)

- 1.9 The direction of the induced current in the coil of a generator depends on the ...

- A length of the coil.
- B speed of rotation of the coil.
- C direction of the magnetic field.
- D strength of the magnetic field. (2)



1.10 The work function of zinc is greater than that of magnesium.

Which ONE of the following statements about the threshold frequencies of the metals is CORRECT?

- A The threshold frequency of zinc is greater than that of magnesium.
- B The threshold frequency of zinc is smaller than that of magnesium.
- C Both zinc and magnesium have the same threshold frequency.
- D The threshold frequencies of zinc and magnesium are independent of their work functions.

(2)  
[20]



**QUESTION 2 (Start on a new page.)**

- 2.1 A person pushes a lawn mower of mass 15 kg at a **constant speed** in a straight line over a flat grass surface with a force of 90 N. The force is directed along the handle of the lawn mower. The handle has been set at an angle of  $40^\circ$  to the horizontal. Refer to the diagram below.

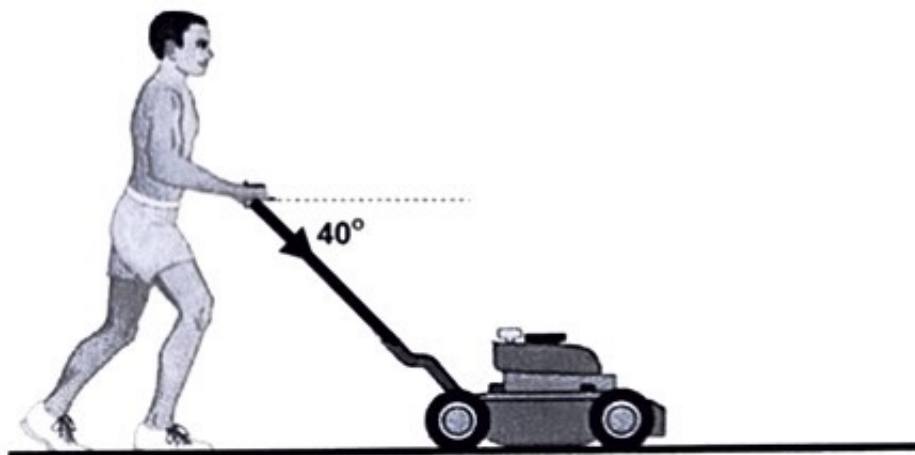

- 2.1.1 Draw a labelled free-body diagram for the lawn mower. (4)
- 2.1.2 Why is it **CORRECT** to say that the moving lawn mower is in equilibrium? (1)
- 2.1.3 Calculate the magnitude of the frictional force acting between the lawn mower and the grass (3)

The lawn mower is now brought to a stop.

- 2.1.4 Calculate the magnitude of the constant force that must be applied through the handle in order to accelerate the lawn mower *from rest* to  $2 \text{ m}\cdot\text{s}^{-1}$  in a time of 3 s. Assume that the frictional force between the lawn mower and grass remains the same as in QUESTION 2.1.3. (6)
- 2.2 Planet Y has a radius of  $6 \times 10^5 \text{ m}$ . A 10 kg mass weighs 20 N on the surface of planet Y. (4)

Calculate the mass of planet Y. [18]





**QUESTION 3 (Start on a new page.)**

A ball is thrown vertically upwards, with velocity  $v$ , from the edge of a roof of a 40 m tall building. The ball takes 1,53 s to reach its maximum height. Ignore air resistance.

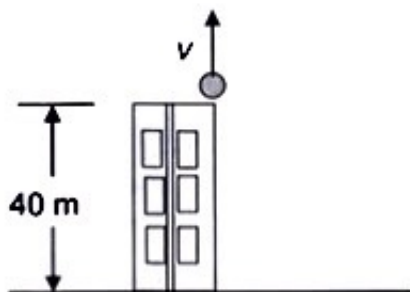

- 3.1 Define the term *free fall*. (2)
- 3.2 Calculate the:
- 3.2.1 Magnitude of the initial velocity  $v$  of the ball (3)
- 3.2.2 Maximum height reached by the ball above the edge of the roof (3)
- 3.3 Take the edge of the roof as reference point. Determine the position of the ball relative to the edge of the roof after 4 s. (3)
- 3.4 Will any of the answers to QUESTIONS 3.2 and 3.3 change if the height of the building is 30 m? Choose from YES or NO. (3)
- Give a reason for the answer. [14]



**QUESTION 4 (Start on a new page.)**

A soccer player kicks a ball of mass  $0,45 \text{ kg}$  to the east. The ball travels horizontally at a velocity of  $9 \text{ m}\cdot\text{s}^{-1}$  along a straight line, without touching the ground, and enters a container lying at rest on its side, as shown in the diagram below. The mass of the container is  $0,20 \text{ kg}$ .

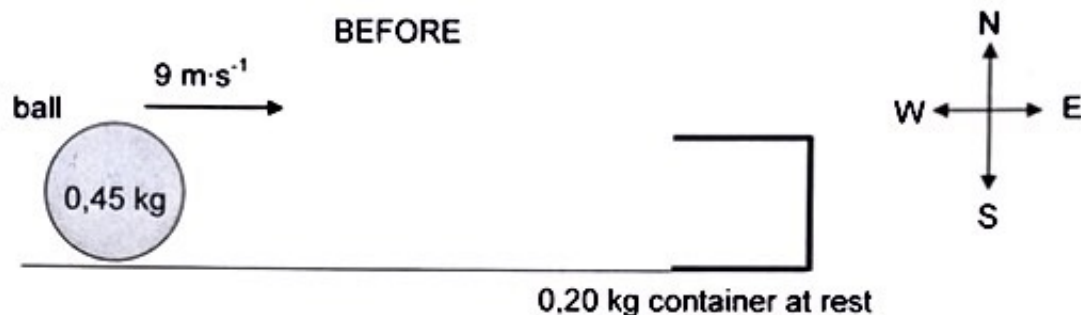

The ball is stuck in the container after the collision. The ball and container now move together along a straight line towards the east. Ignore friction and rotational effects.

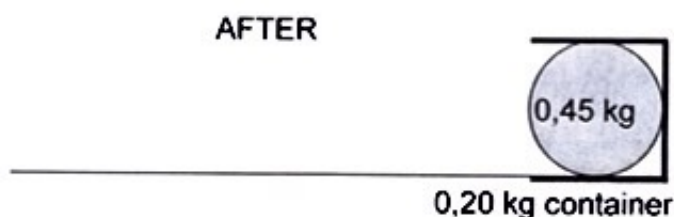

- 4.1 State the principle of conservation of linear momentum in words. (2)
- 4.2 Calculate the magnitude of the velocity of the ball-container system immediately after the collision. (4)
- 4.3 Determine, by means of a suitable calculation, whether the collision between the ball and container is elastic or inelastic. (5)
- [11]**



**QUESTION 5 (Start on a new page.)**

A 70 kg box is initially at rest at the bottom of a ROUGH plane inclined at an angle of  $30^\circ$  to the horizontal. The box is pulled up the plane by means of a light inextensible rope, held parallel to the plane, as shown in the diagram below. The force applied to the rope is 700 N.

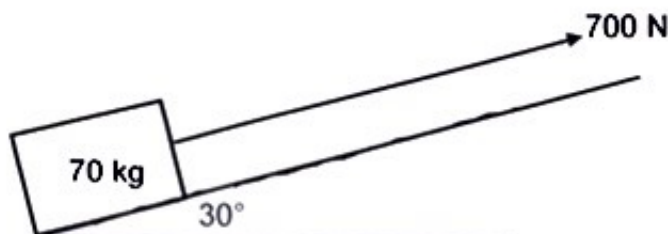

- 5.1 What is the name given to the force in the rope? (1)
- 5.2 Give a reason why the mechanical energy of the system will NOT be conserved as the box is pulled up the plane. (1)

The box is pulled up over a distance of 4 m along the plane. The kinetic frictional force between the box and the plane is 178,22 N.

- 5.3 Draw a labelled free-body diagram for the box as it moves up the plane. (4)
- 5.4 Calculate the work done on the box by the frictional force over the 4 m. (3)
- 5.5 Use energy principles to calculate the speed of the box after it has moved 4 m. (5)
- 5.6 When the box is 4 m up the incline, the rope accidentally breaks, causing the box to slide back down to the bottom of the inclined plane.

What will be the total work done by friction when the box moves up and then down to the bottom of the inclined plane?

(1)  
[15]



**QUESTION 6 (Start on a new page.)**

- 6.1 A patrol car is moving at a constant speed towards a stationary observer. The driver switches on the siren of the car when it is 300 m away from the observer.

The observer records the detected frequency of the sound waves of the siren as the patrol car *approaches, passes and moves away* from him.

The information obtained is shown in the graph below.

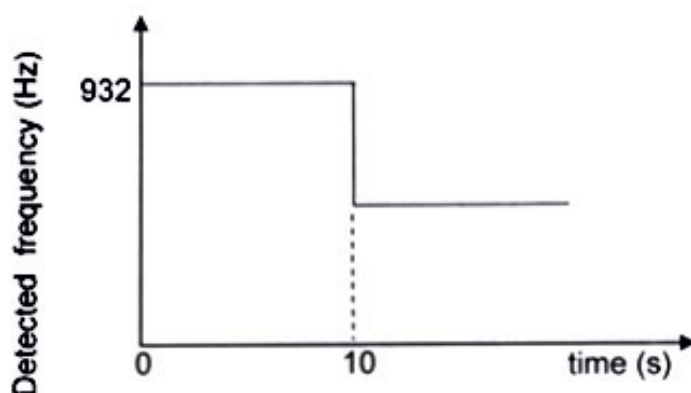

- 6.1.1 Calculate the speed of the patrol car. (2)
- 6.1.2 State the Doppler effect. (2)
- 6.1.3 The detected frequency suddenly changes at  $t = 10$  s. Give a reason for this change. (2)
- Take the speed of sound in air as  $340 \text{ m}\cdot\text{s}^{-1}$ .
- 6.1.4 Calculate the frequency of the sound emitted by the siren. (4)
- 6.2 State TWO applications of the Doppler effect. (2)

**[12]**

**QUESTION 7 (Start on a new page.)**

Two point charges,  $q_1$  and  $q_2$ , are placed 30 cm apart along a straight line. Charge  $q_1 = -3 \times 10^{-9}$  C. Point P is 10 cm to the left of  $q_1$ , as shown in the diagram below. The net electrostatic field at point P is zero.

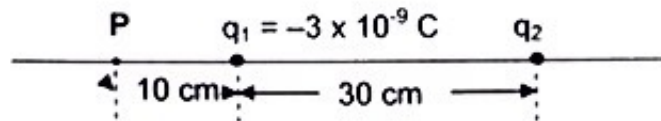

- 7.1 Define the term *electric field at a point*. (2)
- 7.2 State, giving reasons, whether point charge  $q_2$  is positive or negative. (3)
- 7.3 Calculate the magnitude of charge  $q_2$ . (4)
- 7.4 State Coulomb's law in words. (2)
- 7.5 Calculate the magnitude of the electrostatic force exerted by charge  $q_1$  on charge  $q_2$ . (3)
- 7.6 The two charges are now brought into contact with each other and are then separated. A learner draws the electric field pattern for the new charges  $q_3$  and  $q_4$  after contact, as shown below.

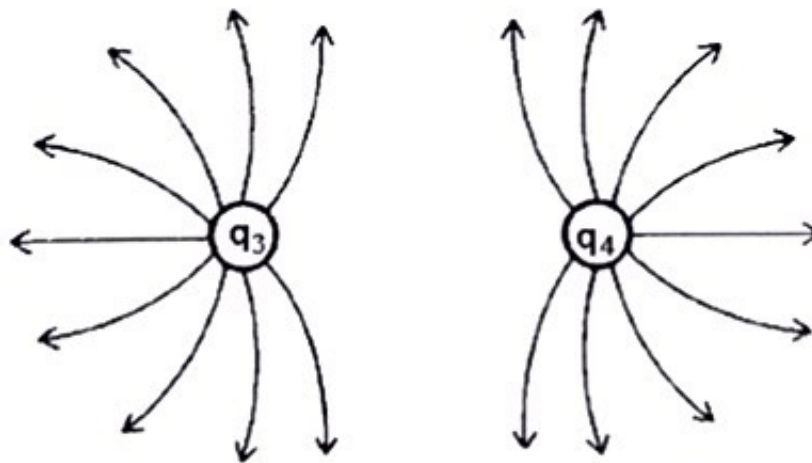

Is the diagram CORRECT? Give a reason for the answer.

(2)  
[16]



**QUESTION 8 (Start on a new page.)**

8.1 Three identical light bulbs, A, B and C, are each rated at 6 W, 12 V.

8.1.1 Define the term *power*. (2)

8.1.2 Calculate the resistance of EACH bulb when used as rated. (3)

The light bulbs are connected in a circuit with a battery having an emf ( $\epsilon$ ) of 12 V and internal resistance ( $r$ ) of  $2 \Omega$ . Refer to the diagram below.

Assume that the resistance of each light bulb is the same as that calculated in QUESTION 8.1.2. Switch S is closed.

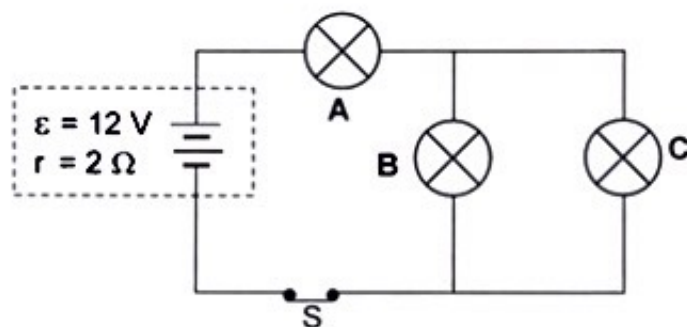

8.1.3 Calculate the total current in the circuit. (5)

8.1.4 Calculate the potential difference across light bulb C. (3)

8.1.5 Explain why light bulb C in the circuit will NOT burn at its maximum brightness. (3)

8.2 Resistors A, B, C and D are connected to a battery having emf ( $\epsilon$ ) and negligible internal resistance, as shown in the diagram below.

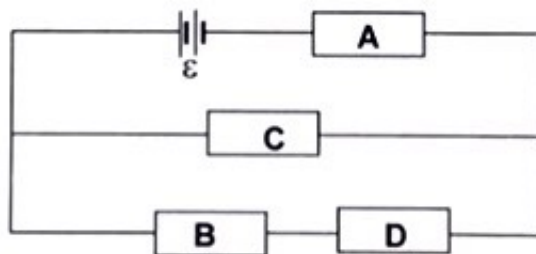

8.2.1 Give a reason why the current in resistor A is greater than that in resistor C. (2)

8.2.2 Resistor C is removed. How will the current in resistor B compare to the current in A? Give a reason for the answer. (2)

[20]



**QUESTION 9 (Start on a new page.)**

The diagram below shows the voltage output of a generator.

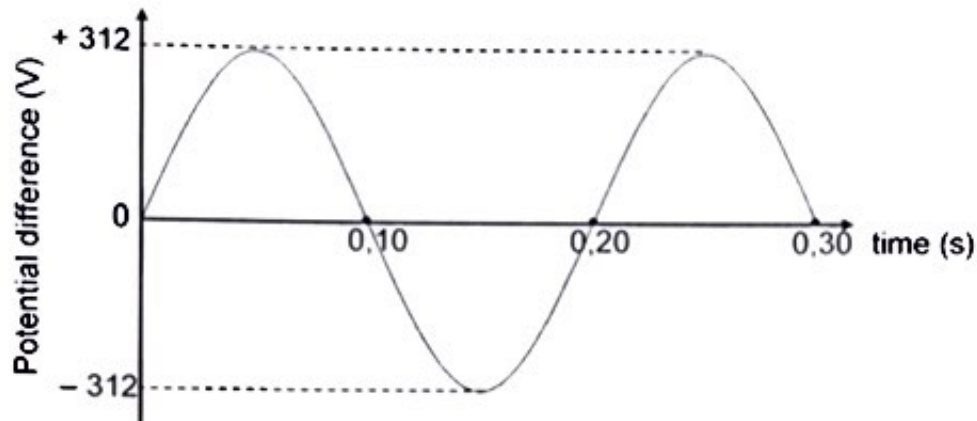

- 9.1 Does this generator have split rings or slip rings? (1)
- 9.2 Which ONE of the diagrams below, A or B, shows the position of the generator's coil at time = 0,10 s? (1)

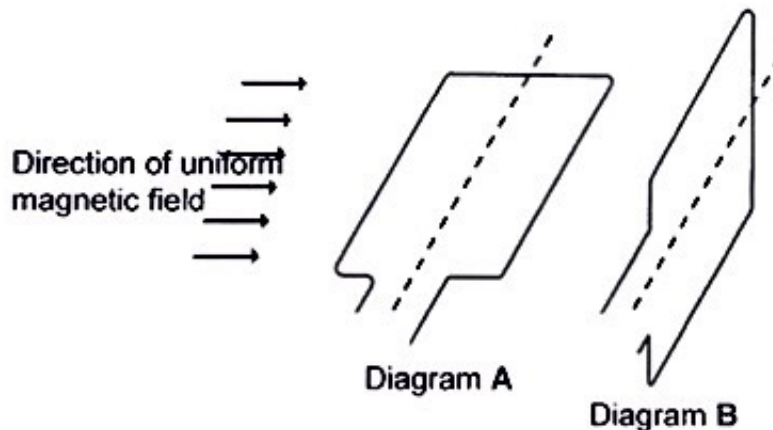

- 9.3 Calculate the root mean square (rms) voltage for this generator. (3)
- 9.4 A device with a resistance of  $40 \Omega$  is connected to this generator.  
Calculate the:
- 9.4.1 Average power delivered by the generator to the device (3)
- 9.4.2 Maximum current delivered by the generator to the device (4)
- [12]**



**QUESTION 10 (Start on a new page.)**

A potassium metal plate is irradiated with light of wavelength  $5 \times 10^{-7} \text{ m}$  in an arrangement, as shown below. The threshold frequency of potassium is  $5,55 \times 10^{14} \text{ Hz}$ .

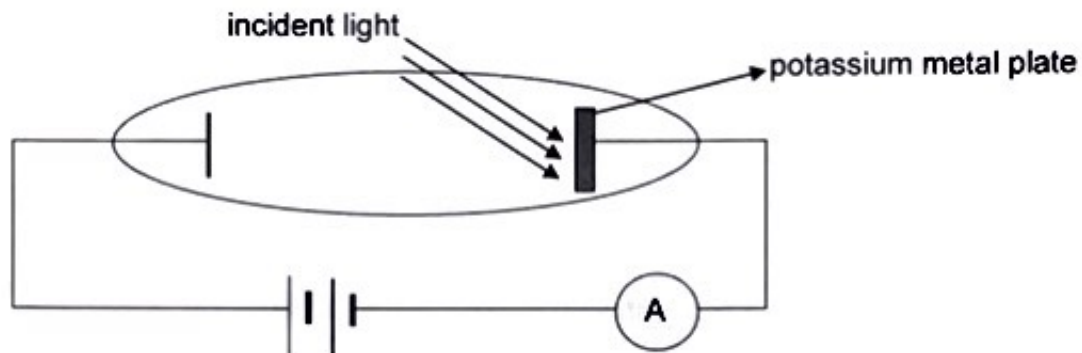

- 10.1 Define the term *threshold frequency*. (2)
- 10.2 Calculate the energy of a photon incident on the metal plate. (3)
- 10.3 Using a suitable calculation, prove that the ammeter will show a reading. (4)
- 10.4 The intensity of the light is now increased. Explain why this change causes an increase in the ammeter reading. (3)
- [12]**

**TOTAL: 150**





**DATA FOR PHYSICAL SCIENCES GRADE 12  
PAPER 1 (PHYSICS)**

**GEGEWENS VIR FISIESTE WETENSAPPE GRAAD 12  
VRAESTEL 1 (FISIKA)**

**TABLE 1: PHYSICAL CONSTANTS/TABEL 1: FISIESTE KONSTANTES**

NAME/NAAM	SYMBOL/SIMBOOL	VALUE/WAARDE
Acceleration due to gravity <i>Swaartekragversnelling</i>	g	$9,8 \text{ m} \cdot \text{s}^{-2}$
Universal gravitational constant <i>Universele gravitasiekonstant</i>	G	$6,67 \times 10^{-11} \text{ N} \cdot \text{m}^2 \cdot \text{kg}^{-2}$
Radius of the Earth <i>Radius van die Aarde</i>	$R_E$	$6,38 \times 10^6 \text{ m}$
Mass of the Earth <i>Massa van die Aarde</i>	$M_E$	$5,98 \times 10^{24} \text{ kg}$
Speed of light in a vacuum <i>Spoed van lig in 'n vakuum</i>	c	$3,0 \times 10^8 \text{ m} \cdot \text{s}^{-1}$
Planck's constant <i>Planck se konstante</i>	h	$6,63 \times 10^{-34} \text{ J} \cdot \text{s}$
Coulomb's constant <i>Coulomb se konstante</i>	k	$9,0 \times 10^9 \text{ N} \cdot \text{m}^2 \cdot \text{C}^{-2}$
Charge on electron <i>Lading op elektron</i>	e	$-1,6 \times 10^{-19} \text{ C}$
Electron mass <i>Elektronmassa</i>	$m_e$	$9,11 \times 10^{-31} \text{ kg}$



TABLE 2: FORMULAE/TABEL 2: FORMULES

## MOTION/BEWEGING

$v_f = v_i + a \Delta t$	$\Delta x = v_i \Delta t + \frac{1}{2} a \Delta t^2$ or/of $\Delta y = v_i \Delta t + \frac{1}{2} a \Delta t^2$
$v_f^2 = v_i^2 + 2a\Delta x$ or/of $v_f^2 = v_i^2 + 2a\Delta y$	$\Delta x = \left( \frac{v_i + v_f}{2} \right) \Delta t$ or/of $\Delta y = \left( \frac{v_i + v_f}{2} \right) \Delta t$

## FORCE/KRAG

$F_{\text{net}} = ma$	$p = mv$
$f_s^{\text{max}} = \mu_s N$	$f_k = \mu_k N$
$F_{\text{net}} \Delta t = \Delta p$ $\Delta p = mv_f - mv_i$	$w = mg$
$F = G \frac{m_1 m_2}{d^2}$ or/of $F = G \frac{m_1 m_2}{r^2}$	$g = G \frac{M}{d^2}$ or/of $g = G \frac{M}{r^2}$

## WORK, ENERGY AND POWER/ARBEID, ENERGIE EN DRYWING

$W = F \Delta x \cos \theta$	$U = mgh$ or/of $E_p = mgh$
$K = \frac{1}{2} mv^2$ or/of $E_k = \frac{1}{2} mv^2$	$W_{\text{net}} = \Delta K$ or/of $W_{\text{net}} = \Delta E_k$ $\Delta K = K_f - K_i$ or/of $\Delta E_k = E_{kf} - E_{ki}$
$W_{\text{nc}} = \Delta K + \Delta U$ or/of $W_{\text{nc}} = \Delta E_k + \Delta E_p$	$P = \frac{W}{\Delta t}$
$P_{\text{ave}} = F v_{\text{ave}}$ / $P_{\text{gemid}} = F v_{\text{gemid}}$	

## WAVES, SOUND AND LIGHT/GOLWE, KLANK EN LIG

$v = f \lambda$	$T = \frac{1}{f}$
$f_L = \frac{v \pm v_L}{v \pm v_s} f_s$ or/of $f_L = \frac{v \pm v_L}{v \pm v_b} f_b$	$E = hf$ or/of $E = \frac{hc}{\lambda}$
$E = W_0 + E_{k(\text{max/maks})}$ or/of $E = W_0 + K_{\text{max/maks}}$ where/waar	
$E = hf$ and/en $W_0 = hf_0$ and/en $E_{k(\text{max/maks})} = \frac{1}{2} mv_{\text{max/maks}}^2$ or/of $K_{\text{max/maks}} = \frac{1}{2} mv_{\text{max/maks}}^2$	



**ELECTROSTATICS/ELEKTROSTATIKA**

$F = \frac{kQ_1Q_2}{r^2}$	$E = \frac{kQ}{r^2}$
$V = \frac{W}{q}$	$E = \frac{F}{q}$
$n = \frac{Q}{e}$ or / of $n = \frac{Q}{q_e}$	

**ELECTRIC CIRCUITS/ELEKTRIESE STROOMBANE**

$R = \frac{V}{I}$	emf ( $\epsilon$ ) = $I(R + r)$ emk ( $\epsilon$ ) = $I(R + r)$
$R_s = R_1 + R_2 + \dots$ $\frac{1}{R_p} = \frac{1}{R_1} + \frac{1}{R_2} + \dots$	$q = I\Delta t$
$W = Vq$ $W = VI\Delta t$ $W = I^2R\Delta t$ $W = \frac{V^2\Delta t}{R}$	$P = \frac{W}{\Delta t}$ $P = VI$ $P = I^2R$ $P = \frac{V^2}{R}$

**ALTERNATING CURRENT/WISSELSTROOM**

$I_{rms} = \frac{I_{max}}{\sqrt{2}}$ / $I_{wgk} = \frac{I_{maks}}{\sqrt{2}}$	$P_{ave} = V_{rms} I_{rms}$ / $P_{gemiddeld} = V_{wgk} I_{wgk}$
$V_{rms} = \frac{V_{max}}{\sqrt{2}}$ / $V_{wgk} = \frac{V_{maks}}{\sqrt{2}}$	$P_{ave} = I_{rms}^2 R$ / $P_{gemiddeld} = I_{wgk}^2 R$
	$P_{ave} = \frac{V_{rms}^2}{R}$ / $P_{gemiddeld} = \frac{V_{wgk}^2}{R}$

