



basic education

Department:
Basic Education
REPUBLIC OF SOUTH AFRICA

**SENIOR CERTIFICATE/
NATIONAL SENIOR CERTIFICATE**

GRADE 12

PHYSICAL SCIENCES: PHYSICS (P1)

NOVEMBER 2020

MARKS: 150

TIME: 3 hours

This question paper consists of 16 pages and 3 data sheets.

INSTRUCTIONS AND INFORMATION

1. Write your examination number and centre number in the appropriate spaces on the ANSWER BOOK.
2. This question paper consists of TEN questions. Answer ALL the questions in the ANSWER BOOK.
3. Start EACH question on a NEW page in the ANSWER BOOK.
4. Number the answers correctly according to the numbering system used in this question paper.
5. Leave ONE line between two subquestions, e.g. between QUESTION 2.1 and QUESTION 2.2.
6. You may use a non-programmable calculator.
7. You may use appropriate mathematical instruments.
8. Show ALL formulae and substitutions in ALL calculations.
9. Round off your FINAL numerical answers to a minimum of TWO decimal places.
10. Give brief motivations, discussions, etc. where required.
11. You are advised to use the attached DATA SHEETS.
12. Write neatly and legibly.

QUESTION 1: MULTIPLE-CHOICE QUESTIONS

Various options are provided as possible answers to the following questions. Choose the answer and write only the letter (A–D) next to the question numbers (1.1 to 1.10) in the ANSWER BOOK, e.g. 1.11 E.

- 1.1 The rate of change of momentum of an object is equal to the ...
- A impulse on the object.
 - B net force acting on the object.
 - C product of the object's mass and its change in velocity.
 - D product of the net force acting on the object and its acceleration. (2)

- 1.2 The gravitational acceleration on the surface of planet **X** with mass M and radius r is g .

The gravitational acceleration on the surface of planet **Y** with mass $2M$ and radius $\frac{1}{2}r$ is ...

- A $\frac{1}{2}g$
- B g
- C $4g$
- D $8g$ (2)

- 1.3 The graph below shows how one of the physical quantities associated with an object in free fall changes with time t . The label on the y-axis is omitted. Ignore air friction.

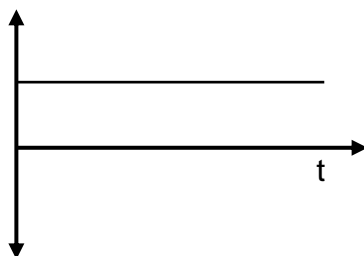

Which ONE of the following physical quantities can be the label on the y-axis?

- A Velocity
- B Position
- C Weight
- D Momentum (2)

- 1.4 A ball of mass m , falling vertically downwards, hits the floor at a speed v and bounces vertically upwards at a speed $0,75v$.

Which ONE of the following combinations regarding the change in momentum of the ball during the collision is CORRECT?

	MAGNITUDE	DIRECTION
A	$0,25mv$	Upwards
B	$0,25mv$	Downwards
C	$1,75mv$	Upwards
D	$1,75mv$	Downwards

(2)

- 1.5 The base SI unit of the physical quantity 'work' is ...

A $\text{kg}\cdot\text{m}\cdot\text{s}^{-1}$

B $\text{kg}\cdot\text{m}^2\cdot\text{s}^2$

C $\text{kg}\cdot\text{m}^2\cdot\text{s}^{-2}$

D $\text{kg}\cdot\text{m}\cdot\text{s}^{-2}$

(2)

- 1.6 The siren of a police car, moving in front of a truck, emits sound waves of frequency f . Both vehicles are travelling at the same constant velocity.

The frequency of the sound heard by the driver of the truck is ...

A f .

B zero.

C greater than f .

D smaller than f .

(2)

- 1.7 Two identical metal spheres, **P** and **R**, on insulated stands, carry different charges. The spheres are brought into contact and then separated again.

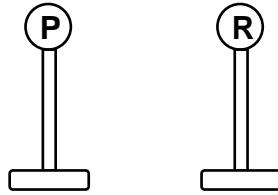

If the charge on sphere **R** AFTER the separation is q , the charge on sphere **P** after the separation is ...

- A q .
 - B zero.
 - C less than q .
 - D greater than q . (2)
- 1.8 An AC generator generates a current with a frequency of 50 Hz.

The number of times that the maximum (peak) current is produced in one second is ...

- A 25.
- B 50.
- C 75.
- D 100. (2)

- 1.9 In the circuit below, the battery has an internal resistance r and an emf \mathcal{E} . A variable resistor R is connected in the circuit and the ammeter and voltmeter register readings.

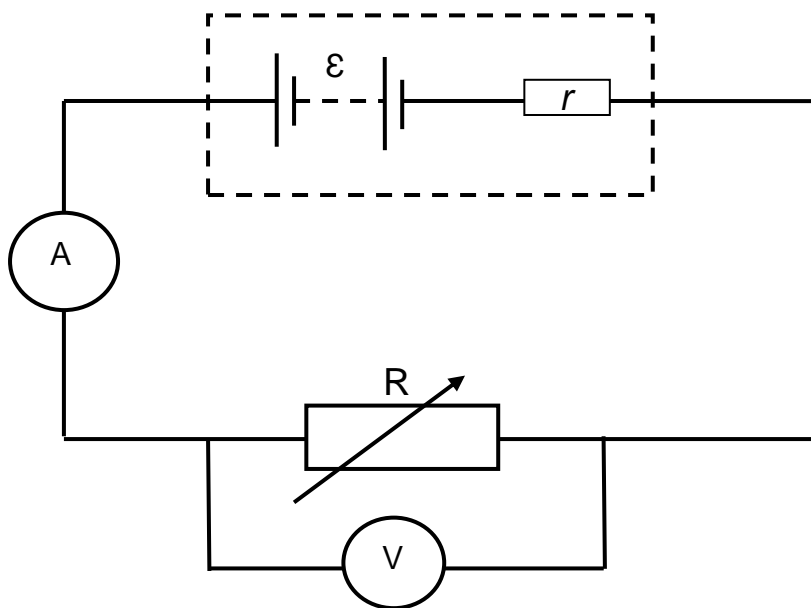

The resistance of the variable resistor R is INCREASED now.

Which ONE of the following combinations is the CORRECT representation of the change in the readings on the ammeter and voltmeter as the resistance of R is increased?

	AMMETER READING	VOLTMETER READING
A	Decreases	Increases
B	Increases	Increases
C	Increases	Decreases
D	Decreases	Decreases

(2)

1.10 The sodium cathode of a photocell is irradiated with ultraviolet light as shown in the diagram below. The ammeter registers a current.

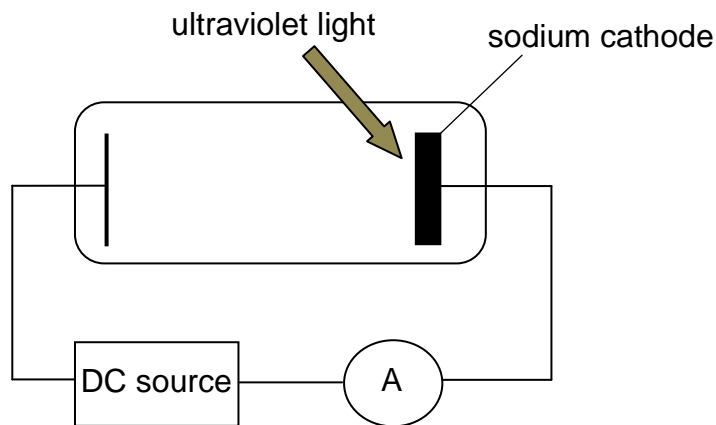

Which ONE of the following changes will INCREASE the ammeter reading?

- A Use a thinner sodium cathode.
- B Increase the intensity of the ultraviolet light.
- C Increase the frequency of the ultraviolet light.
- D Replace the sodium cathode with a cathode of lower work function.

(2)
[20]

QUESTION 2 (Start on a new page.)

A 20 kg block, resting on a rough horizontal surface, is connected to blocks **P** and **Q** by a light inextensible string moving over a frictionless pulley. Blocks **P** and **Q** are glued together and have a combined mass of m .

A force of 35 N is now applied to the 20 kg block at an angle of 40° with the horizontal, as shown below.

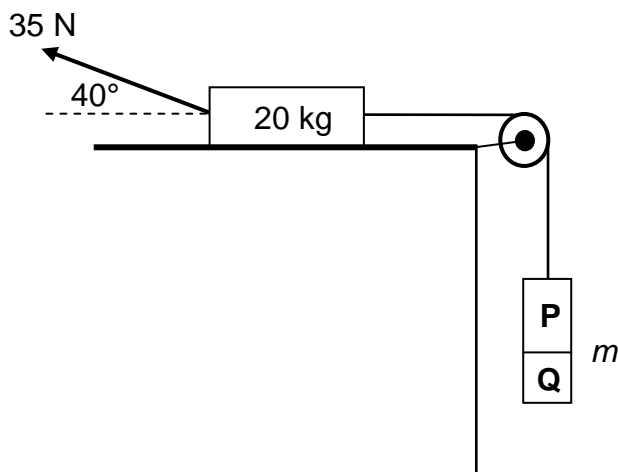

The 20 kg block experiences a frictional force of magnitude 5 N as it moves to the RIGHT at a CONSTANT SPEED.

- 2.1 Define the term *normal force*. (2)
- 2.2 Draw a labelled free-body diagram of the 20 kg block. (5)
- 2.3 Calculate the combined mass m of the two blocks. (5)
- 2.4 At a certain stage of the motion, block **Q** breaks off and falls down.
 How will EACH of the following be affected when this happens?
 - 2.4.1 The tension in the string
 Choose from INCREASES, DECREASES or REMAINS THE SAME. (1)
 - 2.4.2 The velocity of the 20 kg block
 Explain the answer. (3)

[16]

QUESTION 3 (Start on a new page.)

A small ball is dropped from a height of 2 m and bounces a few times after landing on a cement floor. Ignore air friction.

The position-time graph below, not drawn to scale, represents the motion of the ball.

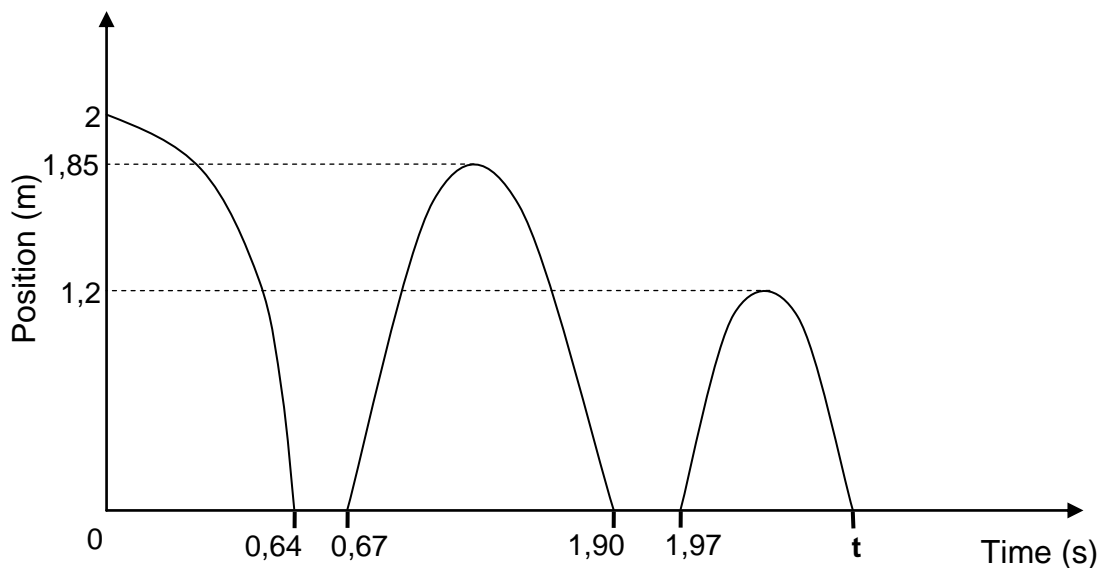

- 3.1 Define the term *free fall*. (2)
 - 3.2 Use the graph and determine:
 - 3.2.1 The time that the ball is in contact with the floor before the first bounce (2)
 - 3.2.2 The time it takes the ball to reach its maximum height after the first bounce (2)
 - 3.2.3 The speed at which the ball leaves the floor at the first bounce (3)
 - 3.2.4 Time **t** indicated on the graph (6)
- [15]**

QUESTION 4 (Start on a new page.)

Ball **P** of mass 0,16 kg, moving east at a speed of $10 \text{ m}\cdot\text{s}^{-1}$, collides head-on with another ball **Q** of mass 0,2 kg, moving west at a speed of $15 \text{ m}\cdot\text{s}^{-1}$. After the collision, ball **P** moves west at a speed of $5 \text{ m}\cdot\text{s}^{-1}$, as shown in the diagram below.

Ignore the effects of friction and the rotational effects of the balls.

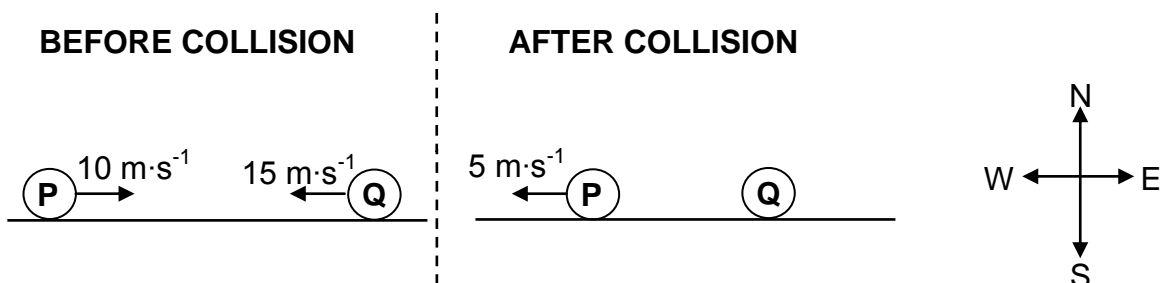

- 4.1 Define the term *momentum* in words. (2)
 - 4.2 Calculate the:
 - 4.2.1 Velocity of ball **Q** after the collision (5)
 - 4.2.2 Magnitude of the impulse on ball **P** during the collision (3)
- [10]**

QUESTION 5 (Start on a new page.)

A roller-coaster car of mass 200 kg, with the engine switched off, travels along track **ABC** which has a rough surface, as shown in the diagram below. At point **A**, which is 10 m above the ground, the speed of the car is $4 \text{ m}\cdot\text{s}^{-1}$.

At point **B**, which is at a height h above the ground, the speed of the car is $2 \text{ m}\cdot\text{s}^{-1}$. During the motion from point **A** to point **B**, $3,40 \times 10^3 \text{ J}$ of energy is used to overcome friction.

Ignore rotational effects due to the wheels of the car.

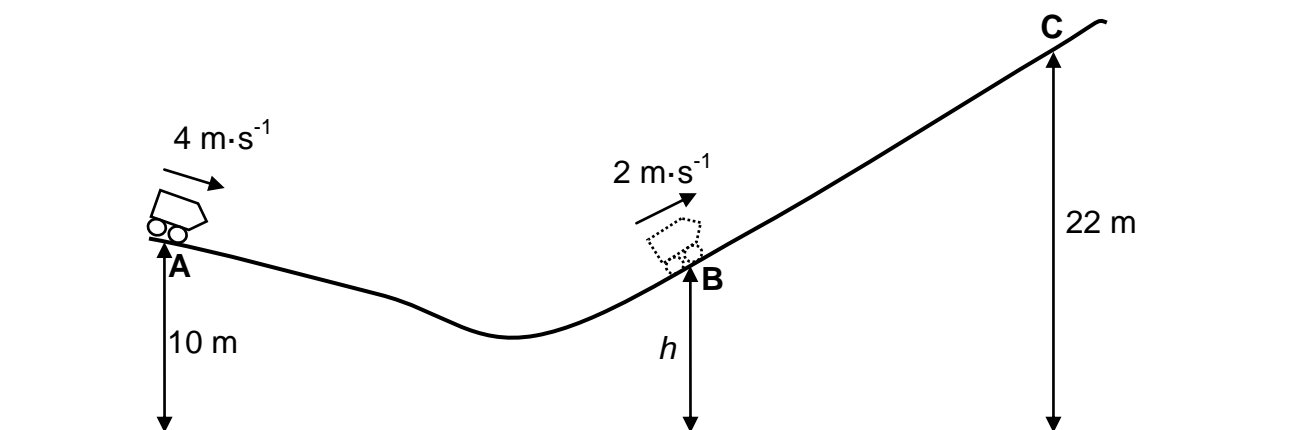

- 5.1 Define the term *non-conservative force*. (2)
- 5.2 Calculate the change in the kinetic energy of the car after it has travelled from point **A** to point **B**. (3)
- 5.3 Use energy principles to calculate the height h . (4)

On reaching point **B**, the car's engine is switched on in order to move up the incline to point **C**, which is 22 m above the ground. While moving from point **B** to point **C**, the car travels for 15 s at a constant speed of $2 \text{ m}\cdot\text{s}^{-1}$, while an average frictional force of 50 N acts on it.

- 5.4 Calculate the power delivered by the engine to move the car from point **B** to point **C**. (5)
- [14]**

QUESTION 6 (Start on a new page.)

The siren of a train, moving at a constant speed along a straight horizontal track, emits sound with a constant frequency. A detector, placed next to the track, records the frequency of the sound waves. The results obtained are as shown in the graph below.

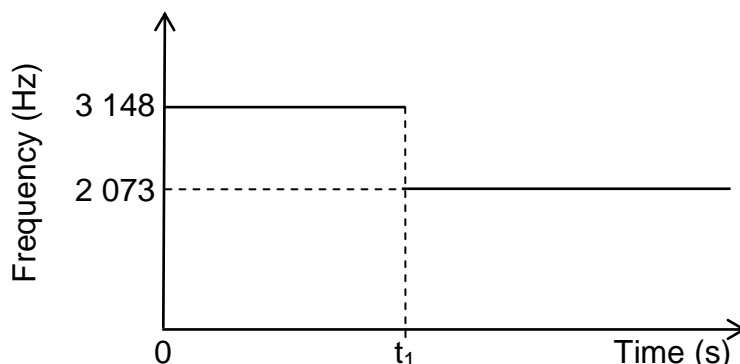

6.1 State the Doppler effect in words. (2)

6.2 Does the detector record the frequency of 3 148 Hz when the train moves TOWARDS the detector or AWAY from the detector? (1)

6.3 Calculate the speed of the train. Take the speed of sound in air as $340 \text{ m}\cdot\text{s}^{-1}$. (6)

6.4 The detector started recording the frequency of the moving train's siren when the train was 350 m away.

Calculate time t_1 indicated on the graph above. (2)
[11]



QUESTION 7 (Start on a new page.)

Two small charged spheres, **A** and **B**, are placed on insulated stands, 0,2 m apart, as shown in the diagram below. They carry charges of $-4 \times 10^{-6} \text{ C}$ and $+3 \times 10^{-6} \text{ C}$ respectively.

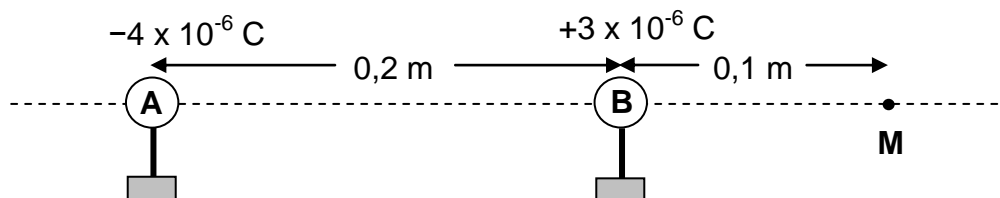

M is a point that is a distance of 0,1 m to the right of sphere **B**.

- 7.1 Calculate the number of electrons in excess on sphere **A**. (3)
- 7.2 Calculate the magnitude of the electrostatic force exerted by sphere **A** on sphere **B**. (3)
- 7.3 Describe the term *electric field*. (2)
- 7.4 Calculate the magnitude of the net electric field at point **M**. (5)

Charged spheres **A** and **B** and another charged sphere **D** are now arranged along a rectangular system of axes, as shown in the diagram below.

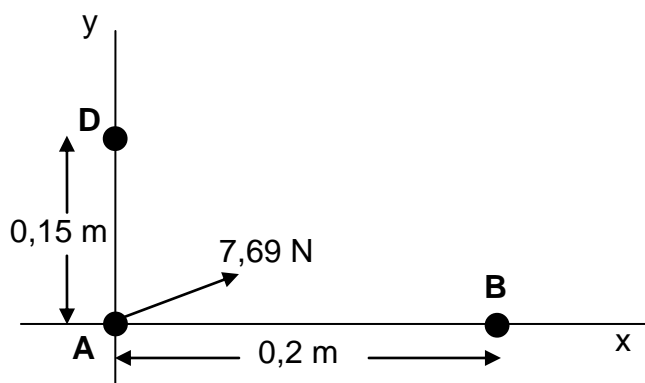

The net electrostatic force experienced by sphere **A** is 7,69 N in the direction as shown in the diagram above.

- 7.5 Is the charge on sphere **D** POSITIVE or NEGATIVE? (1)
 - 7.6 Calculate the magnitude of the charge on sphere **D**. (3)
- [17]**

QUESTION 8 (Start on a new page.)

A battery with an internal resistance of $0,5 \Omega$ and an unknown emf (ϵ) is connected to three resistors, a high resistance voltmeter and an ammeter of negligible resistance, as shown in the circuit diagram below.

The resistance of the connecting wires must be ignored.

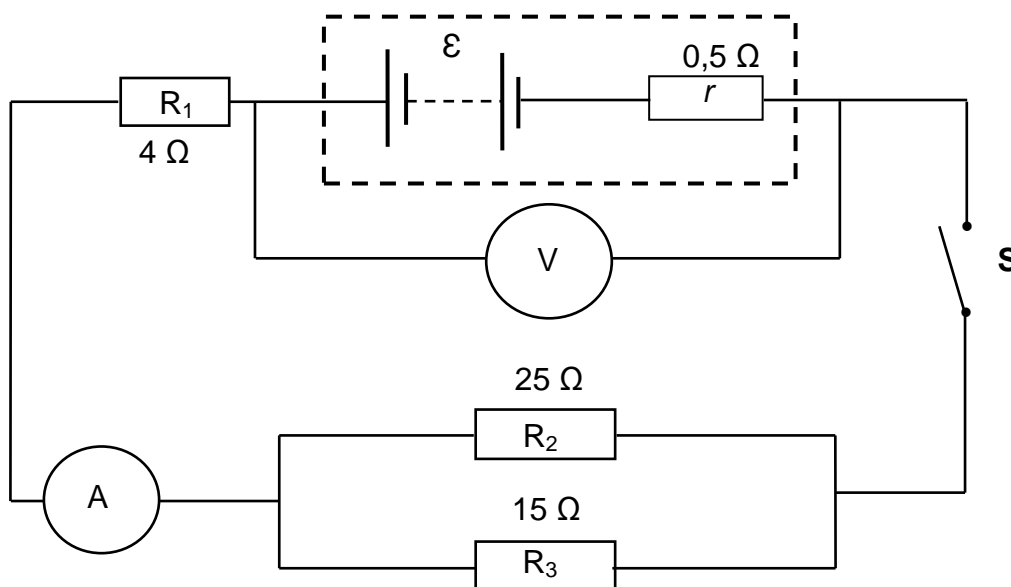

8.1 Define the term *emf* of a battery. (2)

The reading on the voltmeter DECREASES by $1,5 \text{ V}$ when switch **S** is closed.

8.2 Give a reason why the voltmeter reading decreases. (2)

8.3 Calculate the following when switch **S** is closed:

8.3.1 Reading on the ammeter (3)

8.3.2 Total external resistance of the circuit (4)

8.3.3 Emf of the battery (3)

8.4 A learner makes the following statement:

The current through resistor R_3 is larger than the current through resistor R_2 .

Is this statement CORRECT? Choose from YES or NO. Explain the answer. (3)

8.5 The 4Ω resistor is now removed from the circuit.

How will this affect the emf of the battery? Choose from INCREASES, DECREASES or REMAINS THE SAME. (1)

[18]

QUESTION 9 (Start on a new page.)

9.1 A simplified diagram of an electrical machine is shown below.

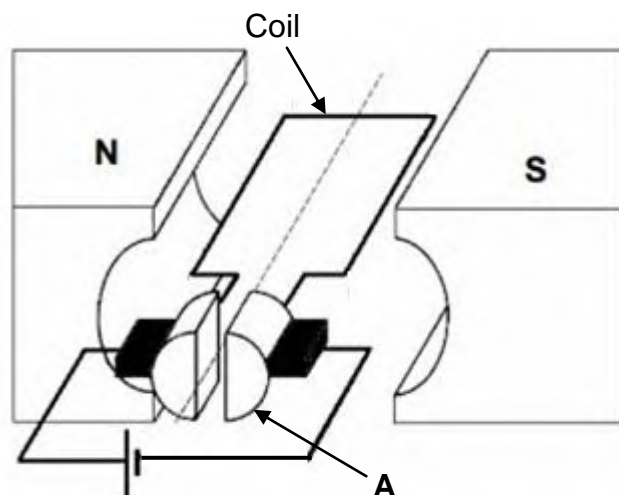

- 9.1.1 Is this machine a DC motor or a DC generator? (1)
- 9.1.2 Write down the energy conversion that takes place while this machine is in operation. (2)
- 9.1.3 Write down the name of component **A** in the diagram. (1)
- 9.1.4 In which direction will the coil, shown in the diagram above, rotate? Choose from **CLOCKWISE** or **ANTICLOCKWISE**. (2)

9.2 An electrical device is marked 200 W ; 220 V.

- 9.2.1 Define the term *rms voltage*. (2)
- 9.2.2 Calculate the resistance of the device. (3)

This device is now connected to a 150 V AC source.

- 9.2.3 Calculate the energy dissipated by the device in 10 minutes. (5)

[16]

QUESTION 10 (Start on a new page.)

An experiment is conducted to investigate the relationship between the frequency of light incident on a metal and the maximum kinetic energy of the emitted electrons from the surface of the metal. This experiment is conducted for three different metals.

The graph below represents the results obtained.

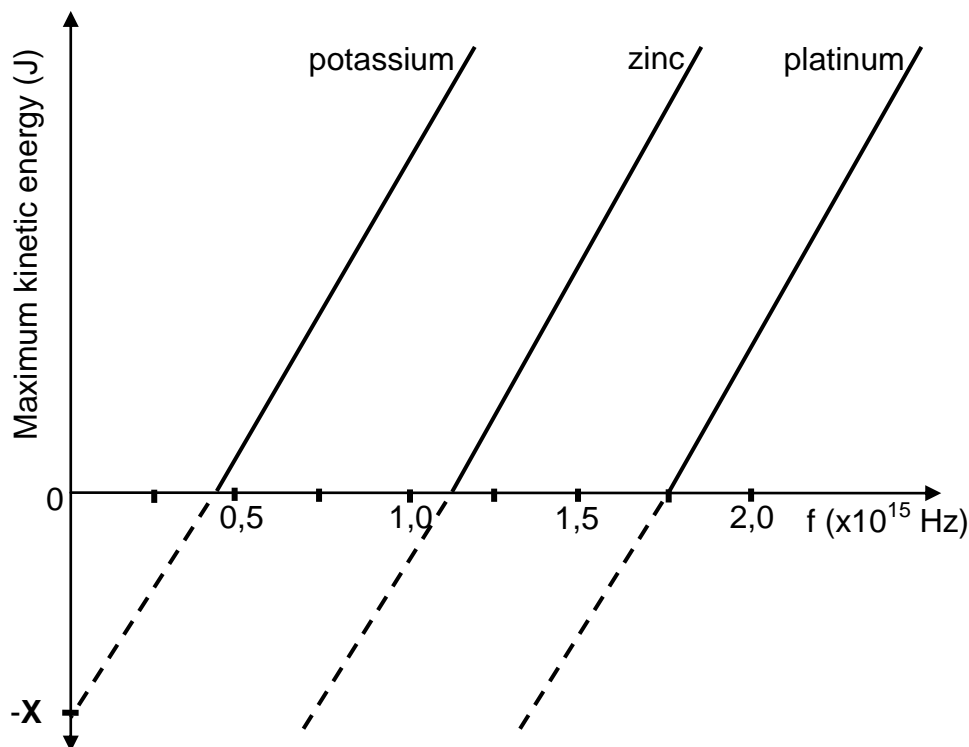

- 10.1 Name the phenomenon on which this experiment is based. (1)
- 10.2 Name the physical quantity represented by **X** on the graph. (1)
- 10.3 Which ONE of the three metals needs incident light with the *largest wavelength* for the emission of electrons?
 Give a reason for the answer. (2)
- 10.4 Define the term *work function* in words. (2)
- 10.5 Calculate the:
 - 10.5.1 Work function of **platinum** (3)
 - 10.5.2 Frequency of the incident light that will emit electrons from the surface of **platinum** with a maximum velocity of $5,60 \times 10^5 \text{ m}\cdot\text{s}^{-1}$ (4)

[13]

TOTAL: 150

**DATA FOR PHYSICAL SCIENCES GRADE 12
 PAPER 1 (PHYSICS)**

**GEGEWENS VIR FISIESTE WETENSKAPPE GRAAD 12
 VRAESTEL 1 (FISIKA)**

TABLE 1: PHYSICAL CONSTANTS/TABEL 1: FISIESTE KONSTANTES

NAME/NAAM	SYMBOL/SIMBOOL	VALUE/WAARDE
Acceleration due to gravity <i>Swaartekragversnelling</i>	g	9,8 m·s ⁻²
Universal gravitational constant <i>Universele gravitasiekonstant</i>	G	6,67 x 10 ⁻¹¹ N·m ² ·kg ⁻²
Radius of the Earth <i>Radius van die Aarde</i>	R _E	6,38 x 10 ⁶ m
Mass of the Earth <i>Massa van die Aarde</i>	M _E	5,98 x 10 ²⁴ kg
Speed of light in a vacuum <i>Spoed van lig in 'n vakuum</i>	c	3,0 x 10 ⁸ m·s ⁻¹
Planck's constant <i>Planck se konstante</i>	h	6,63 x 10 ⁻³⁴ J·s
Coulomb's constant <i>Coulomb se konstante</i>	k	9,0 x 10 ⁹ N·m ² ·C ⁻²
Charge on electron <i>Lading op elektron</i>	e	-1,6 x 10 ⁻¹⁹ C
Electron mass <i>Elektronmassa</i>	m _e	9,11 x 10 ⁻³¹ kg

TABLE 2: FORMULAE/TABEL 2: FORMULES

MOTION/BEWEGING

$v_f = v_i + a \Delta t$	$\Delta x = v_i \Delta t + \frac{1}{2} a \Delta t^2$ or/of $\Delta y = v_i \Delta t + \frac{1}{2} a \Delta t^2$
$v_f^2 = v_i^2 + 2a\Delta x$ or/of $v_f^2 = v_i^2 + 2a\Delta y$	$\Delta x = \left(\frac{v_i + v_f}{2} \right) \Delta t$ or/of $\Delta y = \left(\frac{v_i + v_f}{2} \right) \Delta t$

FORCE/KRAG

$F_{\text{net}} = ma$	$p = mv$
$f_s^{\text{max}} = \mu_s N$	$f_k = \mu_k N$
$F_{\text{net}} \Delta t = \Delta p$ $\Delta p = mv_f - mv_i$	$w = mg$
$F = G \frac{m_1 m_2}{d^2}$ or/of $F = G \frac{m_1 m_2}{r^2}$	$g = G \frac{M}{d^2}$ or/of $g = G \frac{M}{r^2}$

WORK, ENERGY AND POWER/ARBEID, ENERGIE EN DRYWING

$W = F \Delta x \cos \theta$	$U = mgh$ or/of $E_p = mgh$
$K = \frac{1}{2} mv^2$ or/of $E_k = \frac{1}{2} mv^2$	$W_{\text{net}} = \Delta K$ or/of $W_{\text{net}} = \Delta E_k$ $\Delta K = K_f - K_i$ or/of $\Delta E_k = E_{kf} - E_{ki}$
$W_{\text{nc}} = \Delta K + \Delta U$ or/of $W_{\text{nc}} = \Delta E_k + \Delta E_p$	$P = \frac{W}{\Delta t}$
$P_{\text{ave}} = F v_{\text{ave}}$ / $P_{\text{gemid}} = F v_{\text{gemid}}$	

WAVES, SOUND AND LIGHT/GOLWE, KLANK EN LIG

$v = f \lambda$	$T = \frac{1}{f}$
$f_L = \frac{v \pm v_L}{v \pm v_s} f_s$ or/of $f_L = \frac{v \pm v_L}{v \pm v_b} f_b$	$E = hf$ or /of $E = \frac{hc}{\lambda}$
$E = W_0 + E_{k(\text{max})}$ or $E = W_0 + K_{\text{max}}$ where $E = hf$ and $W_0 = hf_0$ and $E_{k(\text{max})} = \frac{1}{2} mv_{\text{max}}^2$ / $K_{\text{max}} = \frac{1}{2} mv_{\text{max}}^2$	
$E = W_0 + E_{k(\text{maks})}$ of $E = W_0 + K_{\text{maks}}$ waar $E = hf$ en $W_0 = hf_0$ en $E_{k(\text{maks})} = \frac{1}{2} mv_{\text{maks}}^2$ / $K_{\text{maks}} = \frac{1}{2} mv_{\text{maks}}^2$	

ELECTROSTATICS/ELEKTROSTATIKA

$F = \frac{kQ_1Q_2}{r^2}$	$E = \frac{kQ}{r^2}$
$V = \frac{W}{q}$	$E = \frac{F}{q}$
$n = \frac{Q}{e}$ or/of $n = \frac{Q}{q_e}$	

ELECTRIC CIRCUITS/ELEKTRIESE STROOMBANE

$R = \frac{V}{I}$	emf (ϵ) = I(R + r) emk (ϵ) = I(R + r)
$R_s = R_1 + R_2 + \dots$ $\frac{1}{R_p} = \frac{1}{R_1} + \frac{1}{R_2} + \dots$	$q = I\Delta t$
$W = Vq$ $W = VI\Delta t$ $W = I^2R\Delta t$ $W = \frac{V^2\Delta t}{R}$	$P = \frac{W}{\Delta t}$ $P = VI$ $P = I^2R$ $P = \frac{V^2}{R}$

ALTERNATING CURRENT/WISSELSTROOM

$I_{\text{rms}} = \frac{I_{\text{max}}}{\sqrt{2}}$ / $I_{\text{wgk}} = \frac{I_{\text{maks}}}{\sqrt{2}}$	$P_{\text{ave}} = V_{\text{rms}} I_{\text{rms}}$ / $P_{\text{gemiddeld}} = V_{\text{wgk}} I_{\text{wgk}}$
$V_{\text{rms}} = \frac{V_{\text{max}}}{\sqrt{2}}$ / $V_{\text{wgk}} = \frac{V_{\text{maks}}}{\sqrt{2}}$	$P_{\text{ave}} = I_{\text{rms}}^2 R$ / $P_{\text{gemiddeld}} = I_{\text{wgk}}^2 R$
	$P_{\text{ave}} = \frac{V_{\text{rms}}^2}{R}$ / $P_{\text{gemiddeld}} = \frac{V_{\text{wgk}}^2}{R}$



basic education

Department:
Basic Education
REPUBLIC OF SOUTH AFRICA



**SENIOR CERTIFICATE/SENIOR SERTIFIKAAT
NATIONAL SENIOR CERTIFICATE/
NASIONALE SENIOR SERTIFIKAAT**

GRADE/GRAAD 12

**PHYSICAL SCIENCES: PHYSICS (P1)
FISIESE WETENSKAPPE: FISIKA (V1)**

NOVEMBER 2020

MARKING GUIDELINES/NASIENRIGLYNE

MARKS/PUNTE: 150

**These marking guidelines consist of 19 pages./
Hierdie nasienriglyne bestaan uit 19 bladsye.**

QUESTION 1/VRAAG 1

- | | | |
|------|------|-----|
| 1.1 | B ✓✓ | (2) |
| 1.2 | D ✓✓ | (2) |
| 1.3 | C ✓✓ | (2) |
| 1.4 | C ✓✓ | (2) |
| 1.5 | C ✓✓ | (2) |
| 1.6 | A ✓✓ | (2) |
| 1.7 | A ✓✓ | (2) |
| 1.8 | D ✓✓ | (2) |
| 1.9 | A ✓✓ | (2) |
| 1.10 | B ✓✓ | (2) |
- [20]**

QUESTION 2/VRAAG 2

2.1

Marking criteria/Nasienriglyne
 If any of the underlined key words/phrases in the correct context are omitted:
 - 1 mark per word/phrase.
Indien enige van die sleutelwoorde/frases in die korrekte konteks weggelaat word:
 - 1 punt per woord/frase

The perpendicular force exerted by a surface on an object in contact with the surface. ✓✓
Die loodregte krag deur 'n oppervlak uitgeoefen op 'n voorwerp wat daarmee in kontak is.

(2)

2.2

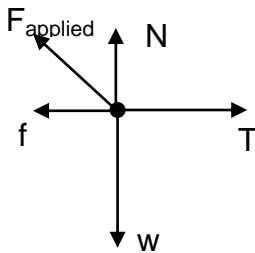

	Accepted symbols/Aanvaarde simbole
N ✓	F_N /Normal/Normal force/173,5N /Normaal/Normaalkrag
f ✓	F_f / f_k /frictional force/wrywingskrag/kinetic frictional force/kinetiese wrywingskrag/5 N
w ✓	F_g /mg/Weight/ $F_{\text{Earth on block}}$ / F_w /Gewig/Gravitational force/Gravitasiekrag/196 N
T ✓	Tension/Spinning/ F_T
F_{applied} ✓ F_{toegepas}	F/Applied force/35 N/Toegepaste krag/ F_A

Notes/Aantekeninge

- Mark is awarded for label and arrow./Punt word toegeken vir byskrif en pyltjie.
- Do not penalise for length of arrows./Moenie vir die lengte van die pyltjies penaliseer nie.
- Deduct 1 mark for any additional force./Trek 1 punt af vir enige addisionele krag.
- If all forces are correctly drawn and labelled, but no arrows, deduct 1 mark. / Indien all kragte korrek geteken en benoem is, maar geen lyne nie, trek 1punt af.

(5)

2.3

<p>For the/Vir die 20 kg:</p> $\left. \begin{aligned} F_{\text{net}} &= ma \\ T - f - F_{Ax} &= ma \end{aligned} \right\} \checkmark$ $T - 5 - 35 \cos 40^\circ \checkmark = 0 \checkmark$ $T = 31,81 \text{ N}$ <p>For/vir m:</p> $\left. \begin{aligned} F_{\text{net}} &= ma \\ mg - T &= ma \\ m(9,8) - 31,81 \checkmark &= 0 \end{aligned} \right\}$ $m = 3,25 \text{ kg} \checkmark$	<p>Marking criteria/Nasienriglyne</p> <ul style="list-style-type: none"> Formula for 20 kg or m kg/Formule vir 20 kg of m kg / $F_{\text{net}} = ma$ ✓ Substitution of zero into either formula ✓ Vervanging van nul in een van die formules All substitutions into F_{net} for 20 kg as shown ✓ Alle vervanging in F_{net} for 20 kg soos getoon Substitution of value of T in eqn for m /Substitusie van waarde vir T in vgl vir m ✓ Final answer/finale antwoord: 3,25 kg ✓
--	---

(5)

2.4.1 Decreases/Neem af ✓

(1)

2.4.2 **POSITIVE MARKING FROM QUESTION 2.3**

POSITIEWE NASIEN VANAF VRAAG 2.3

Moving to the right/Beweeg na regs

Velocity decreases/*snellheid neem af* ✓

Accelerates/Net force to left /*Versnelling/netto krag na links* ✓✓

OR/OF

As the tension force decreases, the net force/acceleration acts in the opposite direction of motion /to the left. ✓✓

Soos die spanning afneem, is daar 'n netto krag/versnelling in die teenoorgestelde rigting / na links

Moving to the left/Beweeg na links

Velocity increases/*snellheid neem toe* ✓

Accelerates/Net force to left /*Versnelling/netto krag na links* ✓✓

(3)
[16]

QUESTION 3/VRAAG 3

3.1 (Motion of an object) under the influence of gravity (weight) only. ✓✓ (2 or 0)
 (*Beweging van 'n voorwerp*) slegs onder die invloed van gravitasie (gewig).

OR/OF

(Motion in which) the only force acting on the object is gravity (weight).
 (*Beweging waar*) die enigste krag wat op die voorwerp inwerk, gravitasie (gewig) is. (2)

3.2.1 $\Delta t = 0,67 - 0,64 = 0,03 \text{ s}$ ✓✓ (2)

3.2.2	<p>OPTION 1/OPSIE 1</p> $\Delta t = \frac{(1,90 - 0,67)}{2} \checkmark$ $= 0,62 \text{ s } \checkmark (0,615 \text{ s})$	<p>OPTION 2/OPSIE 2</p> $\Delta x = v_i \Delta t + \frac{1}{2} a \Delta t^2$ $(-1,85) = 0 + \frac{1}{2} (-9,8) \Delta t^2 \checkmark$ $\Delta t = 0,61 \text{ s } \checkmark (0,6145 \text{ s})$
	<p>OPTION 3/OPSIE 3</p> $\Delta t = \frac{(1,90 + 0,67)}{2} = 1,285 \text{ s}$ $\Delta t = 1,285 - 0,67 \checkmark$ $= 0,62 \text{ s } \checkmark (0,615 \text{ s})$	<p>OPTION 4/OPSIE 4</p> $v_f^2 = v_i^2 + 2a\Delta x$ $0 = v_i^2 + 2(-9,8)(1,85)$ $v_i = 6,02 \text{ m}\cdot\text{s}^{-1}$ $v_f = v_i + a\Delta t$ $0 = 6,02 + (-9,8)\Delta t \checkmark$ $\Delta t = 0,61 \text{ s } \checkmark$

(2)

3.2.3

POSITIVE MARKING FROM QUESTION 3.2.2 POSITIEWE NASIEN VANAF VRAAG 3.2.2	
Marking Criteria/Nasienriglyne	
<ul style="list-style-type: none"> Any appropriate formula/<i>Enige geskikte formule</i> ✓ Correct substitution/<i>Korrekte vervanging</i> ✓ Final answer/<i>Finale antwoord</i>: 5,94 to 6,08 m·s⁻¹ ✓ 	
OPTION 1/OPSIE 1	OPTION 2/OPSIE 2
Upwards positive/ <i>Opwaarts positief</i> $v_f = v_i + a\Delta t$ ✓ $0 = v_i + (-9,8)(0,62)$ ✓ $v_i = 6,08 \text{ m}\cdot\text{s}^{-1}$ (6,076 m·s ⁻¹) ✓	Upwards positive/ <i>Opwaarts positief</i> $\Delta y = v_i\Delta t + \frac{1}{2} a\Delta t^2$ ✓ $1,85 = v_i(0,62) + \frac{1}{2}(-9,8)(0,62)^2$ ✓ $v_i = 6,02 \text{ m}\cdot\text{s}^{-1}$ (6,022 m·s ⁻¹) ✓
Downwards positive/ <i>Afwaarts positief</i> $v_f = v_i + a\Delta t$ ✓ $0 = v_i + (9,8)(0,62)$ ✓ $v_i = -6,08$ $\therefore 6,08 \text{ m}\cdot\text{s}^{-1}$ (6,076 m·s ⁻¹) ✓	Downwards positive/ <i>Afwaarts positief</i> $\Delta y = v_i\Delta t + \frac{1}{2} a\Delta t^2$ ✓ $1,85 = v_i(0,62) + \frac{1}{2}(9,8)(0,62)^2$ ✓ $v_i = -6,02$ $\therefore v_i = 6,02 \text{ m}\cdot\text{s}^{-1}$ (6,022 m·s ⁻¹) ✓
OPTION 3/OPSIE 3	OPTION 4/OPSIE 4
Motion from top to bottom / Beweging vanaf bo na onder Downwards positive/ <i>Afwaarts positief</i> $v_f^2 = v_i^2 + 2a\Delta y$ ✓ $v_f^2 = 0 + 2(9,8)(1,85)$ ✓ $v_f = 6,02 \text{ m}\cdot\text{s}^{-1}$ ✓ initial velocity/ <i>beginsnelheid</i> =6,02 m·s ⁻¹	Upwards positive/ <i>Opwaarts positief</i> $\Delta y = v_i\Delta t + \frac{1}{2} a\Delta t^2$ ✓ $0 = v_i(1,23) + \frac{1}{2}(-9,8)(1,23)^2$ ✓ $v_i = 6,03 \text{ m}\cdot\text{s}^{-1}$ ✓
Upwards positive/ <i>Opwaarts positief</i> $v_f^2 = v_i^2 + 2a\Delta y$ ✓ $v_f^2 = 0 + 2(-9,8)(-1,85)$ ✓ $v_f = 6,02 \text{ m}\cdot\text{s}^{-1}$ ✓ initial velocity/ <i>beginsnelheid</i> =6,02 m·s ⁻¹	Downwards positive/ <i>Afwaarts positief</i> $\Delta y = v_i\Delta t + \frac{1}{2} a\Delta t^2$ ✓ $0 = v_i(1,23) + \frac{1}{2}(9,8)(1,23)^2$ ✓ $v_i = -6,03 \text{ m}\cdot\text{s}^{-1}$ speed/ <i>spoed</i> = 6,03 m·s ⁻¹ ✓
Motion from bottom to top Beweging vanaf onder na bo Downwards positive/ <i>Afwaarts positief</i> $v_f^2 = v_i^2 + 2a\Delta y$ ✓ $0^2 = v_i^2 + 2(9,8)(-1,85)$ ✓ $v_i = 6,02 \text{ m}\cdot\text{s}^{-1}$ ✓	OPTION 5/OPSIE 5
Upwards positive/ <i>Opwaarts positief</i> $v_f^2 = v_i^2 + 2a\Delta y$ ✓ $0 = v_i^2 + 2(-9,8)(1,85)$ ✓ $v_i = 6,02 \text{ m}\cdot\text{s}^{-1}$ ✓	$\Delta y = \left(\frac{v_f + v_i}{2}\right)\Delta t$ ✓ $1,85 = \left(\frac{0 + v_i}{2}\right)(0,62)$ ✓ $v_i = 5,97 \text{ m}\cdot\text{s}^{-1}$ ✓
OPTION 7/OPSIE 7	OPTION 6/OPSIE 6
$(E_p + E_k)_{\text{floor/vloer}} = (E_p + E_k)_{\text{top/bo}}$ ✓ $(mgh + \frac{1}{2}mv^2)_{\text{floor/vloer}} = (mgh + \frac{1}{2}mv^2)_{\text{top/bo}}$ $0 + \frac{1}{2}v^2 = (9,8)(1,85) + 0$ ✓ $v = 6,02 \text{ m}\cdot\text{s}^{-1}$ ✓	$F_{\text{net}}\Delta t = m\Delta v$ $F_{\text{net}}\Delta t = m(v_f - v_i)$ } ✓ $m(9,8)(0,62) = m(0 - v_i)$ ✓ $v_i = 6,08 \text{ m}\cdot\text{s}^{-1}$ ✓

(3)

3.2.4

OPTION/OPSIE 1, 2, 3, 4: Marking criteria/Nasienriglyne	
<p>Calculate initial velocity: Bereken aanvanklike snelheid:</p> <ul style="list-style-type: none"> • Appropriate formula/Gesikhte formule ✓ • Substitution/Vervanging ✓ 	<p>Calculate/Bereken Δt:</p> <ul style="list-style-type: none"> • Appropriate formula/Gesikhte formule ✓ • Substitution/Vervanging ✓ • <u>1,97 s + Δt</u> ✓ • Fin answer/Fin antwoord: 2,95 – 2,97 s ✓
<p>Calculate initial velocity: Bereken beginsnelheid</p> <p>OPTION 1/OPSIE 1 Downwards positive/Afwaarts positief $v_f^2 = v_i^2 + 2a\Delta y$ ✓ $0 = v_i^2 + 2(9,8)(-1,2)$ ✓ $v_i = -4,85 \text{ m}\cdot\text{s}^{-1}$</p> <p>Upwards positive/Opwaarts positief $v_f^2 = v_i^2 + 2a\Delta y$ ✓ $0 = v_i^2 + 2(-9,8)(1,2)$ ✓ $v_i = 4,85 \text{ m}\cdot\text{s}^{-1}$</p> <p>OPTION 2/OPSIE 2 $(E_{\text{mech}})_{\text{top}} = (E_{\text{mech}})_{\text{bot/ond}}$ } ✓ Any one/ $(E_p + E_k)_{\text{top}} = (E_p + E_k)_{\text{Bot/Ond}}$ } Enige een $(mgh + \frac{1}{2}mv^2)_{\text{top}} = (mgh + \frac{1}{2}mv^2)_{\text{Bot/Ond}}$ $(9,8)(1,2) + 0 = 0 + (\frac{1}{2})v^2$ ✓ $v_i = 4,85 \text{ m}\cdot\text{s}^{-1}$ upwards /opwaarts</p> <p>OPTION 3/OPSIE 3 $W_{\text{nc}} = \Delta E_p + \Delta E_k$ $0 = (0 - mgh) + \frac{1}{2}m(v_f^2 - v_i^2)$ } ✓ Any one/ $0 = -(9,8)(1,2) + \frac{1}{2}v_i^2$ } Enige een $v_i = 4,85 \text{ m}\cdot\text{s}^{-1}$ upwards /opwaarts</p> <p>OPTION 4/OPSIE 4 $W_{\text{net}} = \Delta E_k$ $w\Delta x \cos 180^\circ = \frac{1}{2}m(v_f^2 - v_i^2)$ } ✓ Any one/ $(9,8)(1,2)\cos 180^\circ = \frac{1}{2}v_i^2$ } Enige een $v_i = -4,85 \text{ m}\cdot\text{s}^{-1}$</p>	<p>Calculate time Δt Bereken tyd Δt</p> <p><u>Upwards positive</u> <u>Opwaarts positief</u> $\Delta y = v_i\Delta t + \frac{1}{2}a\Delta t^2$ ✓ $1,2 = (4,85)\Delta t + \frac{1}{2}(-9,8)\Delta t^2$ ✓ $\Delta t = 0,4898 \text{ s} / 0,5 \text{ s}$ $t = \underline{1,97 + 2(0,4898)}$ ✓ $= 2,95 \text{ s} / 2,97 \text{ s}$ ✓</p> <p>OR/OF $\Delta y = v_i\Delta t + \frac{1}{2}a\Delta t^2$ ✓ $0 = (4,85)\Delta t + \frac{1}{2}(-9,8)\Delta t^2$ ✓ $\Delta t = 0,9898 \text{ s}$ (or $\Delta t = 0$) $t = \underline{1,97 + 0,9898}$ ✓ = 2,96 s ✓</p> <p><u>Downwards positive</u> <u>Afwaarts positief</u> $\Delta y = v_i\Delta t + \frac{1}{2}a\Delta t^2$ ✓ $1,2 = (-4,85)\Delta t + \frac{1}{2}(9,8)\Delta t^2$ ✓ $\Delta t = 0,4898 \text{ s} / 0,5 \text{ s}$ $t = \underline{1,97 + 2(0,4898)}$ ✓ $= 2,95 \text{ s} / 2,97 \text{ s}$ ✓</p> <p>OR/OF $\Delta y = v_i\Delta t + \frac{1}{2}a\Delta t^2$ ✓ $0 = (4,85)\Delta t + \frac{1}{2}(9,8)\Delta t^2$ ✓ $\Delta t = 0,9898 \text{ s}$ (or $\Delta t = 0$) $t = \underline{1,97 + 0,9898}$ ✓ = 2,96 s ✓</p> <p>OR/OF $v_f = v_i + a\Delta t$ ✓ $-4,85 = 4,85 + (-9,8)\Delta t$ ✓ $\Delta t = 0,9898 \text{ s}$ $\Delta t = \underline{1,97 + 0,9898}$ ✓ = 2,96 s ✓</p> <p>OR/OF <u>Upwards positive</u> <u>Opwaarts positief</u> $v_f = v_i + a\Delta t$ ✓ $0 = 4,85 + (-9,8)\Delta t$ ✓ $\Delta t = 0,4949 \text{ s}$ $\Delta t = \underline{1,97 + (2)(0,4949)}$ ✓ $= 2,96 \text{ s}$ ✓</p> <p>OR/OF $\Delta y = \left(\frac{v_i + v_f}{2}\right)\Delta t$ ✓ $1,2 = \left(\frac{0 + 4,85}{2}\right)\Delta t$ ✓ $\Delta t = 0,4948 \text{ s}$ $\Delta t_{\text{total}} = 2(0,4948) = 0,99 \text{ s}$ $\Delta t = \underline{1,97 + 0,99}$ ✓ = 2,96 s ✓</p>



<p>OPTION 5/OPSIE 5 Downwards positive/Afwaarts positief $\Delta y = v_i \Delta t + \frac{1}{2} a \Delta t^2 \checkmark$ $1,2 \checkmark = 0 + \frac{1}{2}(9,8) \Delta t^2 \checkmark$ $\Delta t = 0,49 \text{ s}$ $t = 1,97 + \checkmark 2(0,49) \checkmark$ $= 2,96 \text{ s} \checkmark$ Upwards positive/Opwaarts positief $\Delta y = v_i \Delta t + \frac{1}{2} a \Delta t^2 \checkmark$ $-1,2 \checkmark = 0 + \frac{1}{2}(-9,8) \Delta t^2 \checkmark$ $\Delta t = 0,49 \text{ s}$ $t = 1,97 + \checkmark 2(0,49) \checkmark$ $= 2,96 \text{ s} \checkmark$</p>	<p>OPTION 5: Marking criteria/ OPSIE 5: Nasienriglyne</p> <ul style="list-style-type: none"> • Formula ✓/Formule • Substitution/Vervanging $\Delta y = 1,2 \checkmark$ • Substitution/Vervanging $0 + \frac{1}{2}(9,8) \Delta t^2$ • $1,97 \text{ s} + \checkmark$ • $2 \Delta t \checkmark$ • Final answer/Finale antwoord: 2,95 - 2,97 s ✓
--	---

(6)
[15]

QUESTION 4/VRAAG 4

4.1 (Linear) momentum (of an object) is the product of mass and velocity. ✓✓
 (Liniêre) momentum (van 'n voorwerp) is die produk van massa en snelheid.
(2 or/of 0)

(2)

4.2.1

<p>OPTION 1/OPSIE 1 East as positive/Oos as positief $\sum p_i = \sum p_f$ $m_p v_{pi} + m_Q v_{Qi} = m_p v_{pf} + m_Q v_{Qf}$ } ✓ Any one/Enige een $(0,16)(10) + (0,2)(-15) \checkmark = (0,16)(-5) + (0,2)v_{Qf} \checkmark$ $v_{Qf} = -3 \text{ m} \cdot \text{s}^{-1}$ $v_{Qf} = 3 \text{ m} \cdot \text{s}^{-1} \checkmark$ west/wes ✓</p>
<p>OPTION 2/OPSIE 2 West as positive/Wes as positief $\sum p_i = \sum p_f$ $m_p v_{pi} + m_Q v_{Qi} = m_p v_{pf} + m_Q v_{Qf}$ } ✓ Any one/Enige een $(0,16)(-10) + (0,2)(15) \checkmark = (0,16)(5) + (0,2)v_{Qf} \checkmark$ $v_{Qf} = 3 \text{ m} \cdot \text{s}^{-1} \checkmark$ west/wes ✓</p>
<p>OPTION 3/OPSIE 3 $\Delta p_p = -\Delta p_Q \checkmark$ $(0,16)(-5 - 10) \checkmark = -(0,2)(v - (-15)) \checkmark$ $v = -3 \text{ m} \cdot \text{s}^{-1}$ $= 3 \text{ m} \cdot \text{s}^{-1} \checkmark$ west/wes ✓</p>

(5)

4.2.2

<p>For ball/ <i>Vir bal P:</i> West as negative/ <i>Wes as negatief</i> Impulse = Δp $F_{\text{net}}\Delta t = \Delta p$ $\Delta p = m(v_{\text{Pf}} - v_{\text{Pi}})$ $= 0,16(-5 - 10) \checkmark$ $= - 2,4$ $\therefore 2,4 \text{ N}\cdot\text{s} \checkmark \quad (2,4 \text{ kg}\cdot\text{m}\cdot\text{s}^{-1})$</p> <p>OR/OF West as positive / <i>Wes as positief</i> Impulse = Δp $F_{\text{net}}\Delta t = \Delta p$ $= m(v_{\text{Pf}} - v_{\text{Pi}})$ $= 0,16(5 - (-10)) \checkmark$ $= 2,4 \text{ N}\cdot\text{s} \checkmark$</p>	<p>POSITIVE MARKING FROM QUESTION 4.2.1 / POSITIEWE NASIEN VANAF VRAAG 4.2.1</p> <p>For ball/ <i>Vir bal Q:</i> West as negative/ <i>Wes as negatief</i> Impulse = Δp $F_{\text{net}}\Delta t = \Delta p$ $= m(v_{\text{Qf}} - v_{\text{Qi}})$ $= 0,2[-3 - (-15)] \checkmark$ $= 2,4 \text{ N}\cdot\text{s} \checkmark \quad (2,4 \text{ kg}\cdot\text{m}\cdot\text{s}^{-1})$</p> <p>OR/OF West as positive / <i>Wes as positief</i> Impulse = Δp $F_{\text{net}}\Delta t = \Delta p$ $= m(v_{\text{Qf}} - v_{\text{Qi}})$ $= 0,16(3 - (15)) \checkmark$ $= - 2,4 \text{ N}\cdot\text{s}$ $\therefore 2,4 \text{ N}\cdot\text{s} \checkmark \quad (2,4 \text{ kg}\cdot\text{m}\cdot\text{s}^{-1})$</p>
---	--

(3)
[10]

QUESTION 5/VRAAG 5

5.1

<p>Marking criteria/Nasienriglyne If any of the underlined key words/phrases in the correct context are omitted: - 1 mark per word/phrase. However, IF: The word “work” is omitted 0 marks <i>Indien enige van die sleutelwoorde/frases in die korrekte konteks weggelaat word:</i> - 1 punt per woord/frase. Maar, INDIEN: Die woord “arbeid” uitgelaat is, 0 punte</p>

A force is non-conservative if the work it does on an object (which is moving between two points) depends on the path taken. $\checkmark\checkmark$
'n Krag is nie-konserwatief indien die arbeid wat dit verrig (op 'n voorwerp wat tussen twee punte beweeg) afhanklik is van die pad.

OR/OF

A force is non-conservative if the work it does on an object depends on the path taken. $\checkmark\checkmark$
'n Krag is nie-konserwatief indien die arbeid wat dit verrig afhanklik is van die pad.

OR/OF

A force is non-conservative if the work it does in moving an object around a closed path is non-zero. $\checkmark\checkmark$
'n Krag is nie-konserwatief indien die arbeid wat dit verrig om 'n voorwerp op 'n geslote pad te beweeg, nie-nul is nie.

(2)

5.2

$$\left. \begin{aligned}
 K &= \frac{1}{2} mv^2 / E_k = \frac{1}{2} mv^2 \\
 \Delta K &= K_f - K_i \\
 \Delta K &= \frac{1}{2}mv_f^2 - \frac{1}{2}mv_i^2 \\
 &= \frac{1}{2}m(v_f^2 - v_i^2) \\
 &= \frac{1}{2}(200)(2^2 - 4^2)\checkmark \\
 \Delta K &= - 1\,200 \text{ J} \checkmark
 \end{aligned} \right\} \checkmark \text{ Any one / Enige een}$$

(3)

5.3

POSITIVE MARKING FROM QUESTION 5.2. POSITIEWE NASIEN VANAF VRAAG 5.2.	
Marking criteria/Nasienriglyne	
<ul style="list-style-type: none"> • Appropriate formula/Geskikte formule ✓ • Substitution into appropriate formula together with/Vervanging in geskikte formule saam met $-3,40 \times 10^3$ ✓✓ • Final answer/Finale antwoord: 8,88 m ✓ 	
OPTION 1/OPSIE 1	
$W_{nc} = \Delta K + \Delta U$ $W_{nc} = \frac{1}{2}mv_f^2 - \frac{1}{2}mv_i^2 + mgh_f - mgh_i$ $= \frac{1}{2}m(v_f^2 - v_i^2) + mg(h_f - h_i)$ $-3,40 \times 10^3 \checkmark = \frac{-1\ 200 + 200(9,8)(h_f - 10)}{\checkmark}$ $h = 8,88\ m \checkmark \quad (8,87765\ m)$	$\left. \begin{array}{l} \\ \\ \\ \end{array} \right\} \checkmark \text{ Any one/Enige een}$
OPTION 2/OPSIE 2	
$E_{(mech/meg)A} + W_f = E_{(mech)B}$ $(E_p + E_k)_A + W_f = (E_p + E_k)_B$ $(mgh + \frac{1}{2}mv^2)_A + W_f = (mgh + \frac{1}{2}mv^2)_B$ $\frac{200(9,8)(10) + \frac{1}{2}(200)(4^2) - 3,40 \times 10^3}{\checkmark} = \frac{200(9,8)(h) + \frac{1}{2}(200)(2)^2}{\checkmark}$ $h = 8,88\ m \checkmark \quad (8,87755)$	$\left. \begin{array}{l} \\ \\ \\ \end{array} \right\} \checkmark \text{ Any one/Enige een}$

OPTION 3/OPSIE 3	
$W_{net} = \Delta K$ $W_f + W_w = \frac{1}{2}mv_f^2 - \frac{1}{2}mv_i^2$ $W_f - \Delta E_p = \frac{1}{2}mv_f^2 - \frac{1}{2}mv_i^2$ $W_f - mg(h_f - h_i) = \frac{1}{2}m(v_f^2 - v_i^2)$ $\frac{-3,40 \times 10^3 - 200(9,8)(h-10)}{\checkmark} = \frac{-1\ 200}{\checkmark}$ $h = 8,88\ m \checkmark \quad (8,87755\ m)$	$\left. \begin{array}{l} \\ \\ \\ \end{array} \right\} \checkmark \text{ Any one/Enige een}$

(4)

5.4

OPTION 1 AND 2/OPSIE 1 EN 2: Marking criteria /Nasienriglyne	
<ul style="list-style-type: none"> • Appropriate formula/Geskikte formule ✓✓ • Work done by friction/Arbeid verrig deur wrywing ✓✓ • Substitution of/Vervanging van $(200)(9,8)(13,12)$ ✓ • Appropriate formula/Geskikte formule • Substitution into power formula/Vervanging in drywingformule • Final answer /Finale antwoord: 1 814,35 W 	
OPTION 1/OPSIE 1	
$W_{nc} = \Delta K + \Delta U$ $W_{engine} + W_f = \frac{1}{2}mv_f^2 - \frac{1}{2}mv_i^2 + mgh_f - mgh_i$ $= \frac{1}{2}m(v_f^2 - v_i^2) + mg(h_f - h_i)$ $W_{engine} + (50)(15)(2)\cos 180^\circ \checkmark\checkmark = 0 + \frac{200(9,8)}{\checkmark}(22 - 8,88)$ $W_{engine} = 27\ 215,20\ J$ $P_{engine} = \frac{W_{engine}}{\Delta t}$ $= \frac{27\ 215,20}{15}$ $= 1\ 814,35\ W$	$\left. \begin{array}{l} \\ \\ \\ \end{array} \right\} \checkmark\checkmark \text{ Any one/Enige een}$

OPTION 2/OPSIE 2

$$\left. \begin{aligned} W_{\text{net}} &= \Delta K \\ W_N + W_{\text{engine}} + W_w + W_f &= 0 \\ W_N + W_{\text{engine}} - \Delta E_p + W_f &= 0 \end{aligned} \right\} \checkmark\checkmark \text{ Any one/Enige een}$$

$$0 + W_{\text{engine}} - (200)(9,8)\checkmark(13,12) + (50)(2)(15)\cos 180^\circ \checkmark\checkmark = 0$$

$$W_{\text{engine}} = 27\,215,20 \text{ J}$$

OR/OF

$$W_{\text{net}} = \Delta K \checkmark\checkmark$$

$$W_N + W_{\text{engine}} + W_{\text{w||}} + W_f = 0$$

$$W_N + W_{\text{engine}} + mg\sin\theta\Delta x\cos 180^\circ + W_f = 0$$

$$0 + W_{\text{engine}} - (200)(9,8)\checkmark\left(\frac{13,12}{\Delta x}\right)\Delta x(-1) + (50)(2)(15)\cos 180^\circ \checkmark\checkmark = 0$$

$$W_{\text{engine}} = 27\,215,20 \text{ J}$$

$$P_{\text{engine}} = \frac{W_{\text{engine}}}{\Delta t}$$

$$= \frac{27\,215,20}{15}$$

$$= 1\,814,35 \text{ W}$$

OPTION/OPSIE 3: Marking criteria/Nasienriglyne Opsie 3

- Appropriate formula/Geskikte formule $\checkmark\checkmark$
- Substitution of/Vervanging van - 50 $\checkmark\checkmark$
- Substitution of/Vervanging van $(-200)(9,8)(0,4373)$ or/of $(-200)(9,8)(0,44)\checkmark$
- Appropriate formula/Geskikte formule
- Substitution into/Vervanging in $P_{\text{ave}} = Fv_{\text{ave}}$
- Final answer/Finale antwoord: 1 814,35 W - 1 824,8 W

OPTION 3/OPSIE 3

$$\left. \begin{aligned} F_{\text{net}} &= ma \\ F_{\text{engine}} + F_{\text{friction}} + F_{g||} &= 0 \end{aligned} \right\} \checkmark\checkmark \text{ Any one/Enige een}$$

$$F_{\text{engine}} + (-50)\checkmark\checkmark + (-200)(9,8)\checkmark(0,4373) = 0$$

$$F_{\text{engine}} = 906,52 \text{ N } (906,52 - 912,4)$$

$$P_{\text{ave}} = Fv_{\text{ave}}$$

$$P_{\text{ave}} = (908,52)(2)$$

$$= 1\,813,04 \text{ W } (1\,824,8 \text{ W})$$

$$\sin\theta = \frac{h}{\Delta x}$$

$$= \frac{13,12}{2(15)}$$

$$= 0,4373$$

OR/OF

$$W = F_{\text{engine}}\Delta x\cos\theta$$

$$= (906,52)(30)\cos 0^\circ$$

$$= 27\,195,6 \text{ J } (27\,372 \text{ W})$$

$$P = \frac{W}{\Delta t} = \frac{27\,195,6}{15} = 1\,813,04 \text{ W } \checkmark \quad (1\,824,8 \text{ W})$$

(5)
 [14]

QUESTION 6/VRAAG 6

6.1

Marking criteria/Nasienriglyne
 If any of the underlined key words/phrases in the correct context are omitted:
 - 1 mark per word/phrase.
 Indien enige van die sleutelwoorde/frases in die korrekte konteks weggelaat word:
 - 1 punt per woord/frase

The change in frequency✓ (or pitch) (of the sound) detected by a listener because the source and the listener have different velocities relative to the medium of propagation. ✓

Die verandering in die frekwensie (of toonhoogte) (van die klank) waargeneem deur 'n luisteraar omdat die bron en die luisteraar verskillende snelhede relatief tot die voortplantingsmedium het.

OR/OF

An (apparent) change in (observed/detected) frequency (pitch), as a result of the relative motion between a source and an observer (listener).

'n (Skynbare) verandering in (waargenome) frekwensie (toonhoogte), as gevolg van die relatiewe beweging tussen die bron en 'n waarnemer/luisteraar.

(2)

6.2

Towards/Nader ✓

(1)

6.3

$$f_L = \frac{v \pm v_L}{v \pm v_s} f_s \quad \text{OR/OF} \quad f_L = \frac{v}{v - v_s} f_s \quad \text{OR/OF} \quad f_L = \frac{v}{v + v_s} f_s$$

$$3148 = \frac{340 + 0}{340 - v_s} f_s \quad \text{OR} \quad 2073 = \frac{340 - 0}{340 + v_s} f_s$$

$$\frac{3148(340 - v_s)}{340 + 0} = \frac{2073(340 + v_s)}{340 - 0}$$

$$v_s = 70 \text{ m} \cdot \text{s}^{-1} \quad (69,95 - 70,16 \text{ m} \cdot \text{s}^{-1})$$

(6)

6.4

POSITIVE MARKING FROM QUESTION 6.3 POSITIEWE NASIEN VANAF VRAAG 6.3		
OPTION 1/OPSIE 1	OPTION 2/OPSIE 2	OPTION 3/OPSIE 3
$\Delta t = \frac{\Delta x}{v}$ $\Delta t = \frac{350}{70} \checkmark$ $\Delta t = 5 \text{ s} \checkmark$	$\Delta x = v_i \Delta t + \frac{1}{2} a \Delta t^2$ $350 = 70 \Delta t + 0 \checkmark$ $\Delta t = 5 \text{ s} \checkmark$	$\Delta x = \left(\frac{v_i + v_f}{2} \right) \Delta t$ $350 = \left(\frac{70 + 70}{2} \right) \Delta t \checkmark$ $\Delta t = 5 \text{ s} \checkmark$

(2)

[11]

QUESTION 7/VRAAG 7

7.1

$$n = \frac{Q}{e} \checkmark$$
$$= \frac{(-)4 \times 10^{-6}}{(-)1,6 \times 10^{-19}} \checkmark$$
$$= 2,5 \times 10^{13} \checkmark \quad (3)$$

7.2 **Electrostatic force on B due to A:/Elektrostatiese krag op B a.g.v. A:**

$$F_{AB} = \frac{kQ_1Q_2}{r^2} \checkmark$$
$$= \left[\frac{9 \times 10^9 (4 \times 10^{-6})(3 \times 10^{-6})}{0,2^2} \right] \checkmark$$
$$= 2,7 \text{ N} \checkmark \quad (3)$$

Ignore negative signs
Ignoreer negatiewe tekens

7.3 **Marking criteria/Nasienriglyne**

If any of the underlined key words/phrases in the correct context are omitted:
- 1 mark per word/phrase.
*Indien enige van die sleutelwoorde/frases in die korrekte konteks weggelaat word:
- 1 punt per woord/frase*

Electric field is a region (in space) where (in which) an (electric) charge experiences a (electric) force. ✓✓
Elektriese veld is 'n gebied (in die ruimte) waarin 'n (elektriese) lading 'n (elektriese) krag ondervind. (2)

7.4

<p>Marking criteria/Nasienriglyne</p> <ul style="list-style-type: none"> • Appropriate formula/Geskikte formule ✓ • Correct substitution for A and B/Korrekte vervanging van A en B ✓✓ • Subtraction of electric fields/Aftrek van elektrieseveld ✓ • Final answer/Finale antwoord: $2,3 \times 10^6 \text{ N}\cdot\text{C}^{-1}$ ✓
<p>OPTION 1/OPSIE 1</p> <p>Electric field at M due to / <i>Elektriese veld by M as gevolg van:</i> $-4 \times 10^{-6} \text{ C}$</p> $E_{AM} = k \frac{Q}{r^2} \checkmark$ $= 9 \times 10^9 \frac{(4 \times 10^{-6})}{(0,3)^2} \checkmark$ $= 4,0 \times 10^5 \text{ N}\cdot\text{C}^{-1} \text{ (to left /links)}$ <p>Electric field at M due to / <i>Elektriese veld by M as gevolg van:</i> $+3 \times 10^{-6} \text{ C}$,</p> $E_{BM} = k \frac{Q}{r^2}$ $= 9 \times 10^9 \frac{(3 \times 10^{-6})}{(0,1)^2} \checkmark$ $= 2,7 \times 10^6 \text{ N}\cdot\text{C}^{-1} \text{ (to right /regs)}$ <p>Net electric field at M / <i>Netto elektrieseveld by M</i></p> $E_{\text{net}} = E_{BM} + E_{AM}$ $= 4,0 \times 10^5 - 2,7 \times 10^6 \checkmark$ $= 2,3 \times 10^6 \text{ N}\cdot\text{C}^{-1} \checkmark \text{ (right/regs)}$ <p>OR/OF</p> <p>Net electric field at M / <i>Netto elektrieseveld by M</i></p> $E_{\text{net}} = E_{BM} + E_{AM}$ $= -4,0 \times 10^5 + 2,7 \times 10^6 \checkmark$ $= -2,3 \times 10^6 \text{ N}\cdot\text{C}^{-1}$ $= 2,3 \times 10^6 \text{ N}\cdot\text{C}^{-1} \checkmark \text{ (right)}$
<p>OPTION 2/OPSIE 2</p> $F_{AM} = \frac{kQ_1Q_2}{r^2} = \frac{(9 \times 10^9)(4 \times 10^{-6})Q}{(0,3)^2} \checkmark = 4 \times 10^5 Q \text{ N}$ $F_{BM} = \frac{kQ_1Q_2}{r^2} = \frac{(9 \times 10^9)(3 \times 10^{-6})Q}{(0,1)^2} \checkmark = 2,7 \times 10^6 Q \text{ N}$ $F_{\text{net}} = 2,7 \times 10^6 Q + (-4 \times 10^5 Q) \checkmark = 2,3 \times 10^6 Q$ $E = \frac{F}{q} \checkmark = \frac{2,3 \times 10^6 Q}{Q} = 2,3 \times 10^6 \text{ N}\cdot\text{C}^{-1} \checkmark \text{ (right/regs)}$

(5)

7.5 Positive/Positief ✓

(1)

7.6

POSITIVE MARKING FROM 7.2/POSITIEWE NASIEN VANAF 7.2	
Marking criteria/Nasienriglyne	
<ul style="list-style-type: none"> • Correct substitution into Pythagoras's equation/Korrekte vervanging in Pythagoras se vergelyking ✓ • Correct substitution into Coulomb's Law/Korrekte vervanging in Coulomb se wet ✓ • Correct answer/Korrekte antwoord ✓ 	
$(F_{\text{net}})^2 = (F_{\text{AD}})^2 + (F_{\text{AB}})^2$ $(7,69)^2 = (F_{\text{AD}})^2 + (2,7)^2 \checkmark$ $F_{\text{AD}} = 7,2 \text{ N}$ $F_{\text{AD}} = \frac{kQ_1Q_2}{r^2}$ $7,2 = \frac{(9 \times 10^9)(4 \times 10^{-6})Q}{(0,15)^2} \checkmark$ $Q_D = 4,5 \times 10^{-6} \text{ C} \checkmark$ OR/OF $F_{\text{AD}} = k \frac{Q_1Q_2}{r^2}$ $= 9 \times 10^9 \frac{(4 \times 10^{-6})Q}{0,15^2} \checkmark$ $= 1,6 \times 10^6 Q$ $F_{\text{net}} = \sqrt{F_{\text{AB}}^2 + F_{\text{AD}}^2} \quad \text{OR/OF} \quad F_{\text{net}}^2 = F_{\text{AB}}^2 + F_{\text{AD}}^2$ $7,69 = \sqrt{2,7^2 + (1,6 \times 10^6 Q)^2} \checkmark$ $Q = 4,50 \times 10^{-6} \text{ C} \checkmark$	



(3)
 [17]

QUESTION 8/VRAAG 8

8.1

Marking criteria/Nasienriglyne

If any of the underlined key words/phrases in the correct context are omitted:
 - 1 mark per word/phrase.
*Indien enige van die sleutelwoorde/frases in die korrekte konteks weggelaat word:
 - 1 punt per woord/frase*

(Maximum) energy provided (work done) by a battery per coulomb/unit charge
 passing through it. ✓✓
*(Maksimum) energie verskaf (arbeid verrig) deur 'n battery per coulomb/
 eenheidslading wat daardeur beweeg.*

Work done by the battery to move a unit coulomb of charge across the
circuit./Arbeid verrig deur die battery om 'n eenheidslading oor die
stroombaan te beweeg. (2)

8.2

Energy (per coulomb of charge) is converted to heat in the battery due to the
internal resistance. ✓✓
Energie (per coulomb lading) word na hitte omskep binne-in die battery a.g.v.
interne weerstand. (2)

8.3.1

$$I = \frac{V}{R} \checkmark$$

$$I = \frac{1,5}{0,5} \checkmark$$

$$= 3 \text{ A} \checkmark$$

(3)

8.3.2

OPTION 1/OPSIE 1	OPTION 2/OPSIE 2
$\frac{1}{R_p} = \frac{1}{R_1} + \frac{1}{R_2} \checkmark$	$R_p = \frac{R_1 R_2}{R_1 + R_2} \checkmark$
$\frac{1}{R_p} = \frac{1}{25} + \frac{1}{15} \checkmark$	$R_p = \frac{(25)(15)}{25+15} \checkmark$
$R_p = 9,375 \Omega$	$R_p = 9,375 \Omega$
$R_{\text{ext}} = 9,375 + 4 \checkmark = 13,38 \Omega \checkmark$ (13,375 Ω)	$R_{\text{ext}} = 9,375 + 4 \checkmark = 13,38 \Omega \checkmark$ (13,375 Ω)

(4)

8.3.3

POSITIVE MARKING FROM QUESTIONS 8.3.1 AND 8.3.2.
POSITIEWE NASIEN VANAF VRAAG 8.3.1 EN 8.3.2.

OPTION 1/OPSIE 1

$$\begin{aligned} \mathcal{E} &= I(R + r) \checkmark \\ &= 3(13,38 + 0,5) \checkmark \\ &= 41,64 \text{ V} \checkmark \quad (\text{Range/Gebied: } 41,625 - 41,64) \end{aligned}$$

OPTION 2/OPSIE 2

$$\begin{aligned} \mathcal{E} &= V_{\text{ext/eks}} + V_{\text{int}} \checkmark \\ &= (3)(13,38) + 1,5 \checkmark \\ &= 41,64 \text{ V} \checkmark \quad (\text{Range/Gebied: } 41,625 - 41,64) \end{aligned}$$

(3)

8.4 Yes. ✓/Ja

For the same voltage/potential difference, ✓

a larger current will flow through a smaller resistor ($I = \frac{V}{R}$) ✓

Vir dieselfde spanning/ potensiaalverskil

sal 'n groter stroom deur die kleiner weerstand vloei ($I = \frac{V}{R}$).

OR/OF

$$I \propto \frac{1}{R} \checkmark, V = \text{constant /konstant} \checkmark$$

I is inversely proportional to R and V is constant.

I is omgekeerd eweredig aan R en V is konstant.

OR/OF

$$\begin{aligned} V_{\parallel} &= IR \\ &= (3)(9,38) \\ &= 28,14 \text{ V} \end{aligned}$$

$$I_{R2} = \frac{V}{R} = \frac{28,14}{25} = 1,13 \text{ A} \checkmark$$

$$I_{R3} = \frac{V}{R} = \frac{28,14}{15} = 1,88 \text{ A} \checkmark$$

OR/OF

V is the same / V is dieselfde ✓

$$\left. \begin{aligned} I_{15\Omega} &= \frac{25}{40} I \\ I_{25\Omega} &= \frac{15}{40} I \end{aligned} \right\} \checkmark$$

(3)

8.5 Remains the same/Bly dieselfde ✓

(1)

[18]

QUESTION 9/VRAAG 9

9.1.1 (DC) motor/(GS-)motor ✓ (1)

9.1.2 **POSITIVE MARKING FROM QUESTION 9.1.1**

POSITIEWE NASIEN VANAF VRAAG 9.1.1

Electrical to mechanical /kinetic (energy) ✓✓ (2 or 0)

Elektriese na meganiese/kinetiese (energie) (2 of 0) (2)

9.1.3 Split ring/commutator/Splitring/kommutator ✓ (1)

9.1.4 Anticlockwise/antiklosgewys ✓✓ (2)

9.2.1 (The rms voltage/value of AC is) the AC voltage/potential difference which dissipates the same amount of energy/heat/power as an equivalent DC voltage/potential difference. ✓✓ (2 or 0)

(Die wkg-waarde van WS is) die WS-potensiaalverskil/spanning wat dieselfde hoeveelheid energie/hitte/drywing verbruik as 'n ekwivalente GS-spanning/potensiaalverskil. (2 of 0)

ACCEPT/AANVAAR

The rms voltage/value of AC is the DC potential difference which dissipates the same amount of energy/heat/power as AC.

Die wkg-waarde van WS is die GS-potensiaalverskil wat dieselfde hoeveelheid energie/hitte/drywing verbruik as die WS. (2)

9.2.2

<u>Marking criteria/Nasienriglyne</u>		
<ul style="list-style-type: none"> • Appropriate formula for P_{ave}/Gesikte formule vir P_{ave} ✓ • Substitution to calculate/Vervanging vir berekening van R ✓ • Final answer/Finale antwoord: 242Ω ✓ 		
<u>OPTION 1/OPSIE 1</u>	<u>OPTION 2/OPSIE 2</u>	<u>OPTION 3/OPSIE 3</u>
$P_{ave} = \frac{V_{rms}^2}{R} \checkmark$ $200 = \frac{220^2}{R} \checkmark$ $R = 242 \Omega \checkmark$	$P_{ave} = V_{rms} I_{rms} \checkmark$ $200 = I_{rms} (220)$ $I_{rms} = 0,909 \text{ A (0,91)}$ $R = \frac{V_{rms}}{I_{rms}} \text{ or/of } R = \frac{V}{I}$ $R = \frac{220}{0,909} \checkmark$ $R = 242 \Omega \checkmark (241,76 \Omega)$	$P_{ave} = V_{rms} I_{rms} \checkmark$ $200 = I_{rms} (220)$ $I_{rms} = 0,909 \text{ A (0,91)}$ $P_{ave} = I_{rms}^2 R$ $200 = (0,909)^2 R \checkmark$ $R = 242 \Omega \checkmark$ $(241,52 \Omega)$

(3)

9.2.3

<p>Marking criteria for options 1,2 and 3 /Nasienriglyne vir opsies 1,2 en 3</p> <ul style="list-style-type: none"> • Appropriate formula to calculate P or I_{rms} /Geskikte formule om P of I_{rms} te bereken ✓ • Substitution/Vervanging ✓ • Formula for P or W containing Δt/Formule vir P of W wat Δt bevat ✓ • Substitution/Vervanging ✓ • Final answer/Finale antwoord: 55 785,12 J ✓ 		
<p>POSITIVE MARKING FROM QUESTION 9.2.2. POSITIEWE NASIEN VANAF VRAAG 9.2.2.</p>		
<p>OPTION 1/OPSIE 1 Marking criteria / Nasienriglyne</p> <ul style="list-style-type: none"> • Appropriate formula for W containing V/Geskikte formule vir W wat V bevat ✓✓ • Substitution/Vervanging ✓✓ • Final answer/Finale antwoord: 55 785,12 J ✓ 		
$W = \frac{V^2 \Delta t}{R} \checkmark \checkmark$ $= \frac{(150^2)(10 \times 60)}{242} \checkmark$ $= 55\,785,12 \text{ J} \checkmark$		
<p>OPTION 2/OPSIE 2</p> $P_{ave} = \frac{V_{rms}^2}{R} \checkmark$ $= \frac{150^2}{242} \checkmark$ $P_{av} = 92,975 \text{ W}$ $P = \frac{W}{\Delta t} \checkmark$ $92,975 = \frac{W}{(10)(60)} \checkmark$ $W = 55\,785,12 \text{ J} \checkmark$ $(55\,785,12 - 55\,896 \text{ J})$	<p>OPTION 3/OPSIE 3</p> $R = \frac{V_{rms}}{I_{rms}} \checkmark / R = \frac{V}{I}$ $242 = \frac{150}{I_{rms}} \checkmark$ $I_{rms} = 0,620 \text{ A}$ $P_{ave} = I_{rms} V_{rms}$ $= (0,62)(150) \checkmark$ $= 92,97 \text{ W} (93 \text{ W})$ $P = \frac{W}{\Delta t} \checkmark$ $92,975 = \frac{W}{(10)(60)} \checkmark$ $W = 55\,785,12 \text{ J} \checkmark$ $(55\,785,12 - 55\,896 \text{ J})$	<p>OPTION 4/OPSIE 4</p> $R = \frac{V_{rms}}{I_{rms}} \checkmark / R = \frac{V}{I}$ $242 = \frac{150}{I_{rms}} \checkmark$ $I_{rms} = 0,620 \text{ A}$ $W = I^2 R \Delta t \checkmark$ $= (0,62)^2 (242)(10)(60) \checkmark$ $= 55\,814,88 \text{ J} \checkmark$ $(55\,785,12 - 55\,896 \text{ J})$ <p>OR/OF</p> $W = VI \Delta t$ $= (150)(0,62)(600)$ $= 55\,800 \text{ J}$
<p>OPTION 5/OPSIE 5</p> $P_{ave} = \frac{V_{rms}^2}{R} \checkmark = \frac{150^2}{242} \checkmark = 92,975 \text{ W}$ $P_{ave} = I_{rms}^2 R$ $92,975 = I_{rms}^2 (242)$ $I_{rms} = 0,6198 \text{ A}$ $W = I^2 R \Delta t \checkmark$ $= (0,6198)^2 (242)(10)(60) \checkmark$ $= 55\,778,88 \text{ J} \checkmark$		



QUESTION 10/VRAAG 10

10.1 Photoelectric effect/Fotoëlektriese effek ✓ (1)

10.2 Work function (of potassium)/Werksfunksie/Arbeidsfunksie (van kalium) ✓ (1)

10.3 Potassium/Kalium ✓
 It has the lowest work function / threshold frequency / highest threshold wavelength. ✓
Dit het die laagste arbeidsfunksie / drumpelfrekwensie / hoogste drumpel golflengte. (2)

10.4 **Marking criteria/Nasienriglyne**
 If any of the underlined key words/phrases in the correct context are omitted:
 - 1 mark per word/phrase.
Indien enige van die sleutelwoorde/frases in die korrekte konteks weggelaat word: - 1 punt per woord/frase

The work function of a metal is the minimum energy that an electron (in the metal) needs to be emitted/ejected from the metal / surface. ✓
Die werksfunksie/arbeidsfunksie van 'n metaal is die minimum energie benodig om 'n elektron vanaf 'n oppervlak / metaal vry te stel. (2)

10.5.1 $W_o = hf_o$ ✓
 $= (6,63 \times 10^{-34})(1,75 \times 10^{15})$ ✓
 $= 1,160 \times 10^{-18} \text{ J}$ ✓

OR/OF
 $E = W_o + E_{k(\max)}$
 $hf = W_o + E_{k(\max)}$ } ✓ Any one / Enigeen
 $(6,63 \times 10^{-34})(1,75 \times 10^{15}) = W_o + 0$ ✓
 $W_o = 1,160 \times 10^{-18} \text{ J}$ ✓ (3)

10.5.2 **POSITIVE MARKING FROM QUESTION 10.5.1.**
POSITIEWE NASIEN VANAF VRAAG 10.5.1.

$E = W_o + E_{k(\max)}$
 $hf = hf_o + \frac{1}{2}mv_{\max}^2$ } ✓ Any one/Enige een
 $(6,63 \times 10^{-34})f$ ✓ $= \frac{1,160 \times 10^{-18}}{2} + \frac{1}{2} (9,11 \times 10^{-31}) (5,60 \times 10^5)^2$ ✓
 $\therefore f = 1,97 \times 10^{15} \text{ Hz}$ ✓ (4)

[13]

TOTAL/TOTAAL: 150