



basic education

Department:
Basic Education
REPUBLIC OF SOUTH AFRICA

**NATIONAL
SENIOR CERTIFICATE**

GRADE 12

PHYSICAL SCIENCES: PHYSICS (P1)

FEBRUARY/MARCH 2015

MARKS: 150

TIME: 3 hours

This question paper consists of 17 pages and 3 data sheets.

INSTRUCTIONS AND INFORMATION

1. Write your centre number and examination number in the appropriate spaces on the ANSWER BOOK.
2. This question paper consists of TEN questions. Answer ALL the questions in the ANSWER BOOK.
3. Start EACH question on a NEW page in the ANSWER BOOK.
4. Number the answers correctly according to the numbering system used in this question paper.
5. Leave ONE line between two subquestions, for example between QUESTION 2.1 and QUESTION 2.2.
6. You may use a non-programmable calculator.
7. You may use appropriate mathematical instruments.
8. You are advised to use the attached DATA SHEETS.
9. Show ALL formulae and substitutions in ALL calculations.
10. Round off your final numerical answers to a minimum of TWO decimal places.
11. Give brief motivations, discussions, et cetera where required.
12. Write neatly and legibly.

QUESTION 1: MULTIPLE-CHOICE QUESTIONS

Four options are provided as possible answers to the following questions. Each question has only ONE correct answer. Write only the letter (A–D) next to the question number (1.1–1.10) in the ANSWER BOOK, for example 1.11 D.

1.1 Which ONE of the following forces always acts perpendicular to the surface on which a body is placed?

- A Normal force
- B Frictional force
- C Gravitational force
- D Tension force

(2)

1.2 Two isolated bodies, **A** and **B**, having masses m and $2m$ respectively, are placed a distance r apart.

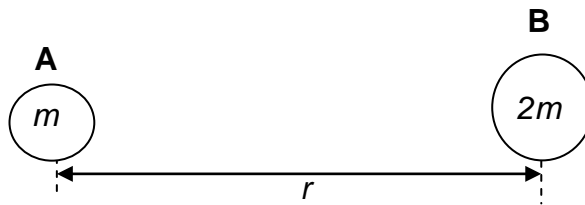

Consider the following statements regarding the gravitational force exerted by the bodies on each other.

- (i) The force exerted by **B** on body **A** is half that exerted by **A** on body **B**.
- (ii) The force exerted on the bodies is independent of the masses of the bodies.
- (iii) The force exerted on body **A** by **B** is equal but opposite to that exerted on body **B** by **A**.
- (iv) The forces will always be attractive.

Which of the statements above is/are TRUE?

- A (i), (ii) and (iv) only
- B (ii), (iii) and (iv) only
- C (iii) and (iv) only
- D (iv) only

(2)

- 1.3 A ball is released from a height above the floor. The ball falls vertically and bounces off the floor a number of times. Ignore the effects of friction and assume that the collision of the ball with the floor is elastic. Take the point of release of the ball as the reference point and downward direction as positive.

Which ONE of the following is a CORRECT representation of the position-time graph for the motion of the ball?

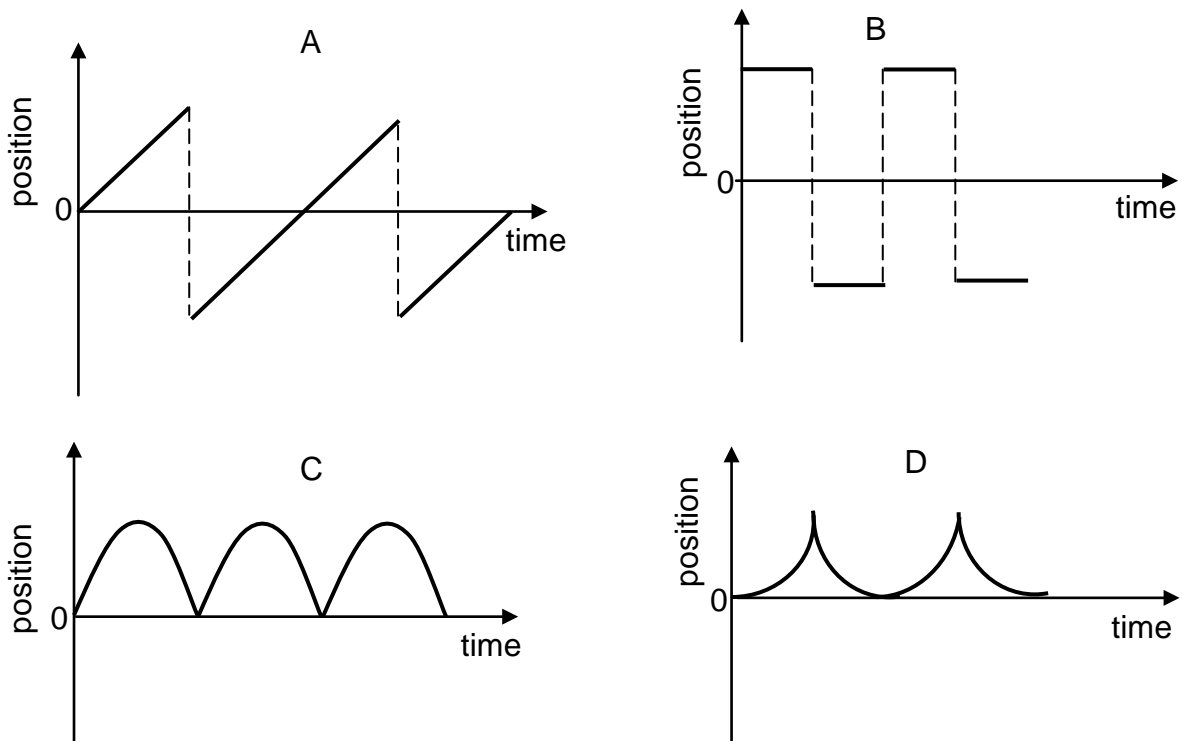

(2)

- 1.4 Two bodies undergo an INELASTIC collision in the absence of friction. Which ONE of the following combinations of momentum and kinetic energy of the system is CORRECT?

	MOMENTUM	KINETIC ENERGY
A	Not conserved	Conserved
B	Conserved	Not conserved
C	Not conserved	Not conserved
D	Conserved	Conserved

(2)

- 1.5 The speed of a bicycle increases from $2 \text{ m}\cdot\text{s}^{-1}$ to $8 \text{ m}\cdot\text{s}^{-1}$. Its kinetic energy increases by a factor of ...
- A 4.
 - B 6.
 - C 8.
 - D 16. (2)
- 1.6 Which ONE of the following CANNOT be explained using the Doppler effect?
- A Emission of electrons from a metal surface
 - B 'Flow meters' used in hospitals
 - C Red spectral lines from distant stars being shifted
 - D Observed frequency of light from moving bodies being higher than expected (2)
- 1.7 The magnitude of an electric field, a distance r from a point charge is E . The magnitude of an electric field, a distance $2r$ from the same point charge will be ...
- A $\frac{1}{4}E$
 - B $\frac{1}{2}E$
 - C $2E$
 - D $4E$ (2)

- 1.8 Three identical light bulbs are connected in a circuit as shown below. The resistances of the battery and connecting wires can be ignored.

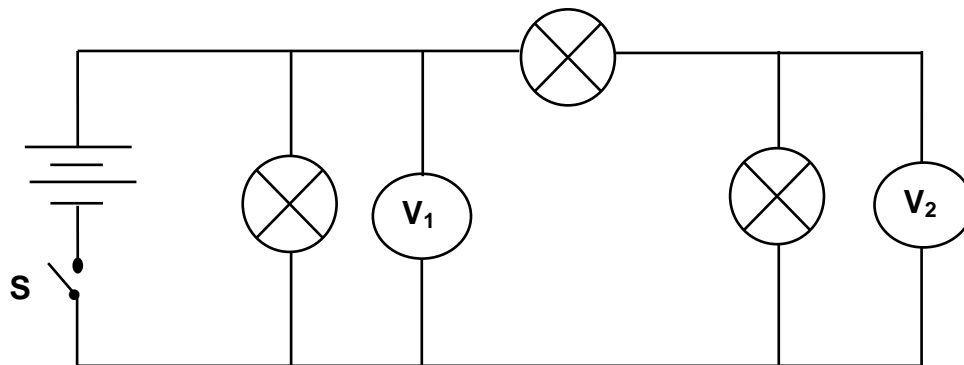

Which ONE of the following statements is CORRECT when switch **S** is closed?

The reading on V_1 is ...

- A half that on V_2 .
- B equal to that on V_2 .
- C twice that on V_2 .
- D three times that on V_2 . (2)

- 1.9 The speed of rotation of the coils in an AC generator is increased. Which ONE of the following combinations of frequency and output voltage for the generator will occur as a result of the change?

	FREQUENCY	OUTPUT VOLTAGE
A	Increases	Increases
B	No change	Increases
C	Decreases	Decreases
D	Increases	No change

(2)

1.10 The spectrum of an element from a star shows some absorption lines. These lines are produced because ...

- A atoms absorb energy when moving from an excited state to a lower energy state.
- B a cold gas absorbs certain frequencies of light passing through it.
- C a hot gas absorbs certain frequencies of light passing through it.
- D atoms release energy when moving from an excited state to a lower energy state.

(2)
[20]

QUESTION 2 (Start on a new page.)

A block of mass 1 kg is connected to another block of mass 4 kg by a light inextensible string. The system is pulled up a rough plane inclined at 30° to the horizontal, by means of a constant 40 N force parallel to the plane as shown in the diagram below.

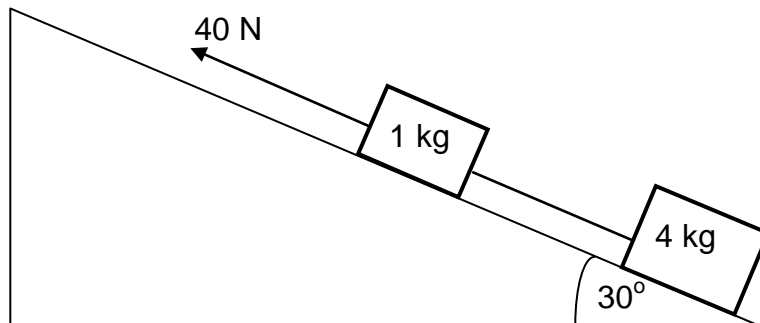

The magnitude of the kinetic frictional force between the surface and the 4 kg block is 10 N. The coefficient of kinetic friction between the 1 kg block and the surface is 0,29.

- 2.1 State Newton's third law in words. (2)
 - 2.2 Draw a labelled free-body diagram showing ALL the forces acting on the **1 kg block** as it moves up the incline. (5)
 - 2.3 Calculate the magnitude of the:
 - 2.3.1 Kinetic frictional force between the 1 kg block and the surface (3)
 - 2.3.2 Tension in the string connecting the two blocks (6)
- [16]**

QUESTION 3 (Start on a new page.)

An object is released from rest from a point **X**, above the ground as shown in the diagram below. It travels the last 30 m (**BC**) in 1,5 s before hitting the ground. Ignore the effects of air friction.

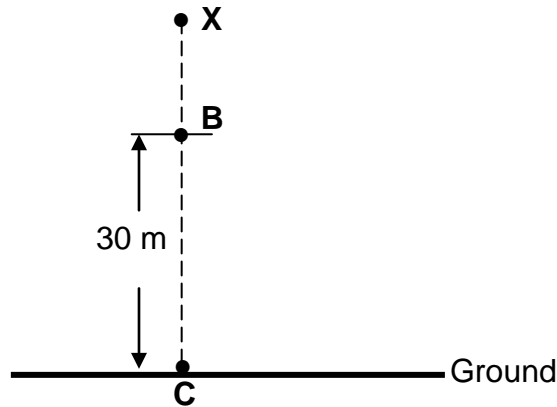

- 3.1 Name the type of motion described above. (1)
- 3.2 Calculate the:
- 3.2.1 Magnitude of the velocity of the object at point **B** (4)
- 3.2.2 Height of point **X** above the ground (5)

After hitting the ground, the object bounces once and then comes to rest on the ground.

- 3.3 Sketch an acceleration-time graph for the entire motion of the object. (3)
- [13]**

QUESTION 4 (Start on a new page.)

The diagram below shows a bullet of mass 20 g that is travelling horizontally. The bullet strikes a stationary 7 kg block and becomes embedded in it. The bullet and block together travel on a rough horizontal surface a distance of 2 m before coming to a stop.

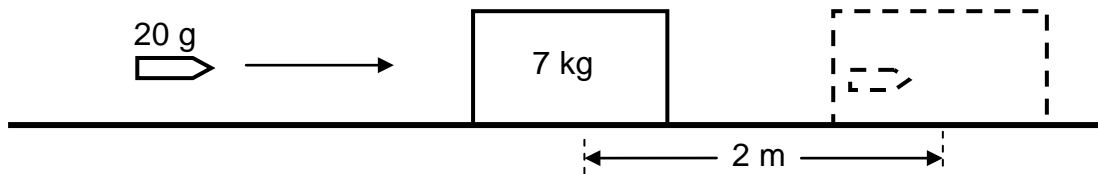

- 4.1 Use the work-energy theorem to calculate the magnitude of the velocity of the bullet-block system immediately after the bullet strikes the block, given that the frictional force between the block and surface is 10 N. (5)
 - 4.2 State the *principle of conservation of linear momentum* in words. (2)
 - 4.3 Calculate the magnitude of the velocity with which the bullet hits the block. (4)
- [11]**

QUESTION 5 (Start on a new page.)

A 5 kg block is released from rest from a height of 5 m and slides down a frictionless incline to point **P** as shown in the diagram below. It then moves along a frictionless horizontal portion **PQ** and finally moves up a second rough inclined plane. It comes to a stop at point **R** which is 3 m above the horizontal.

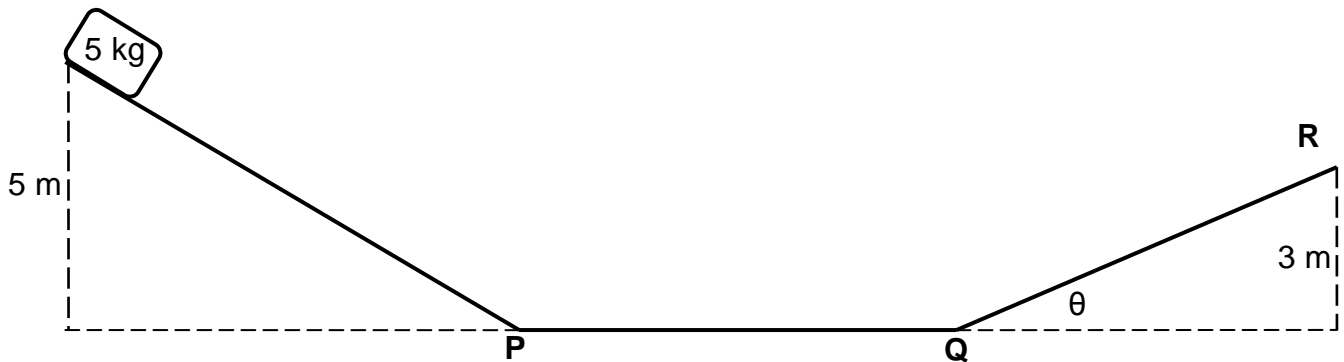

The frictional force, which is a non-conservative force, between the surface and the block is 18 N.

- 5.1 Using ENERGY PRINCIPLES only, calculate the speed of the block at point **P**. (4)
 - 5.2 Explain why the kinetic energy at point **P** is the same as that at point **Q**. (2)
 - 5.3 Explain the term *non-conservative force*. (2)
 - 5.4 Calculate the angle (θ) of the slope **QR**. (7)
- [15]**

QUESTION 6 (Start on a new page.)

The Doppler effect is applicable to both sound and light waves. It also has very important applications in our everyday lives.

- 6.1 A hooter on a stationary train emits sound with a frequency of 520 Hz, as detected by a person standing on the platform. Assume that the speed of sound is $340 \text{ m}\cdot\text{s}^{-1}$ in still air.

Calculate the:

- 6.1.1 Wavelength of the sound detected by the person (2)
- 6.1.2 Wavelength of the sound detected by the person when the train moves towards him/her at a constant speed of $15 \text{ m}\cdot\text{s}^{-1}$ with the hooter still emitting sound (6)
- 6.2 Explain why the wavelength calculated in QUESTION 6.1.1 differs from that obtained in QUESTION 6.1.2. (2)
- 6.3 Use your knowledge of the Doppler effect to explain *red shifts*. (2)
- [12]**

QUESTION 7 (Start on a new page.)

Two identical negatively charged spheres, **A** and **B**, having charges of the **same magnitude**, are placed 0,5 m apart in vacuum. The magnitude of the electrostatic force that one sphere exerts on the other is $1,44 \times 10^{-1}$ N.

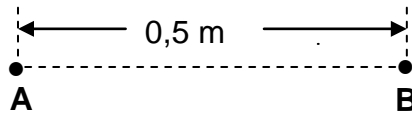

7.1 State Coulomb's law in words. (2)

7.2 Calculate the:

7.2.1 Magnitude of the charge on each sphere (4)

7.2.2 Excess number of electrons on sphere **B** (3)

7.3 **P** is a point at a distance of 1 m from sphere **B**.

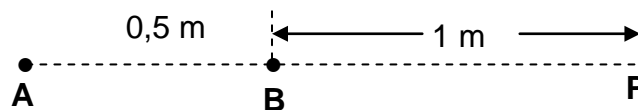

7.3.1 What is the direction of the net electric field at point **P**? (1)

7.3.2 Calculate the number of electrons that should be removed from sphere **B** so that the net electric field at point **P** is $3 \times 10^4 \text{ N}\cdot\text{C}^{-1}$ to the right. (8)

[18]

QUESTION 8 (Start on a new page.)

8.1 Learners want to construct an electric heater using one of two wires, **A** and **B**, of different resistances. They conduct experiments and draw the graphs as shown below.

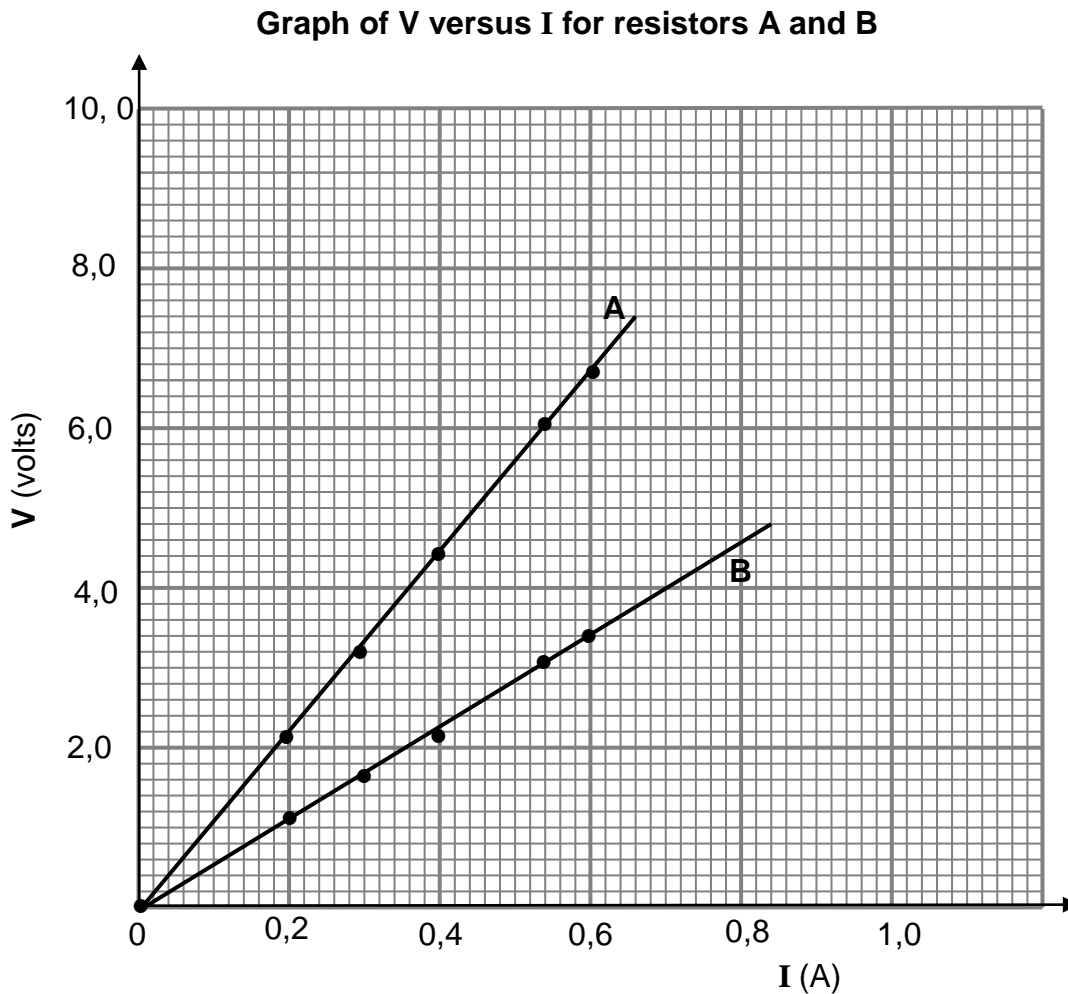

8.1.1 Apart from temperature, write down TWO other factors that the learners should consider to ensure a fair test when choosing which wire to use. (2)

8.1.2 Assuming all other factors are kept constant, state which ONE of the two wires will be the most suitable to use in the heater.

Use suitable calculations to show clearly how you arrive at the answer. (8)

- 8.2 In the circuit below the reading on ammeter **A** is 0,2 A. The battery has an emf of 9 V and internal resistance r .

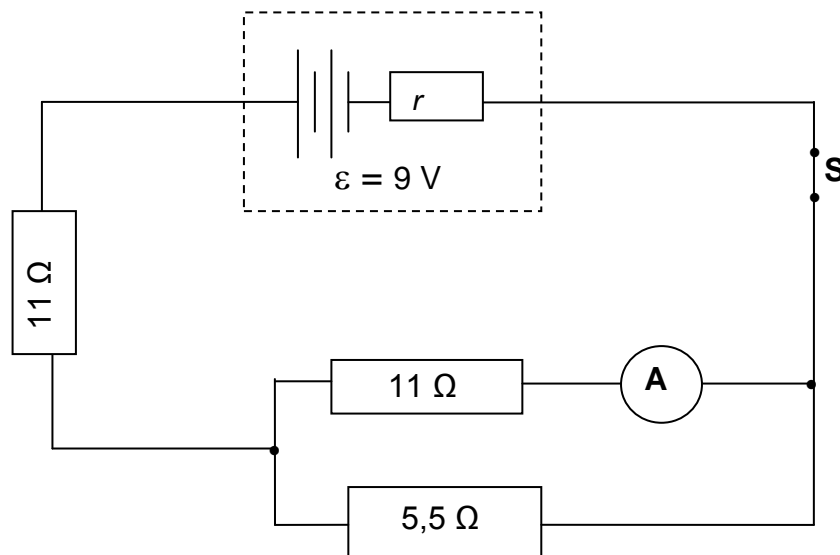

- 8.2.1 Calculate the current through the $5,5\ \Omega$ resistor. (3)
- 8.2.2 Calculate the internal resistance of the battery. (7)
- 8.2.3 Will the ammeter reading INCREASE, DECREASE or REMAIN THE SAME if the $5,5\ \Omega$ resistor is removed from the circuit? Give a reason for the answer. (2)
- [22]**

QUESTION 9 (Start on a new page.)

The graph below shows the output voltage from a household AC generator for one cycle of rotation of the coils.

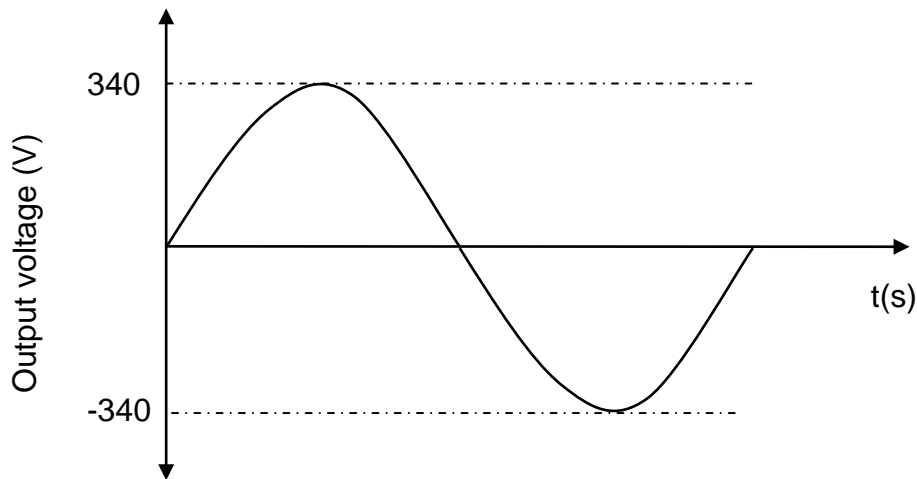

9.1 A 100 W light bulb is connected to this generator and it glows at its maximum brightness. Use the information from the graph to calculate the:

9.1.1 Resistance of the bulb (5)

9.1.2 rms current through the bulb (3)

9.2 Give ONE reason why AC voltage is preferred to DC voltage for everyday use. (1)

[9]

QUESTION 10 (Start on a new page.)

A learner uses photocells to determine the maximum kinetic energy of ejected photoelectrons. One photocell has a caesium cathode and the other has a sodium cathode. Each photocell is radiated by ultraviolet light from the same source as shown below.

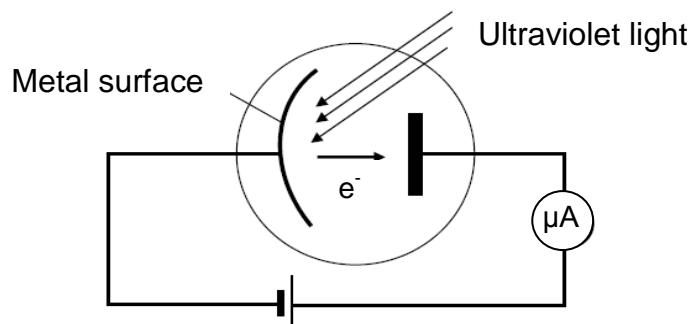

The incomplete results obtained are shown in the table below.

NAME OF THE METAL	WORK FUNCTION OF THE METAL (J)	MAXIMUM KINETIC ENERGY OF PHOTOELECTRONS (J)
Caesium	$3,36 \times 10^{-19}$	$2,32 \times 10^{-19}$
Sodium	$3,65 \times 10^{-19}$	E_K

- 10.1 Define the term *work function of a metal*. (2)
- 10.2 Use the information in the table to calculate the wavelength of the ultraviolet light used in the experiment. (4)
- 10.3 Calculate the maximum kinetic energy, E_K , of an electron ejected from the sodium metal. (4)
- 10.4 The intensity of the incident ultraviolet light was then increased.
- 10.4.1 Give a reason why this change does NOT affect the maximum kinetic energy of the ejected photoelectrons. (1)
- 10.4.2 How does the increased intensity affect the reading on the ammeter? Write down only INCREASES, DECREASES or REMAINS THE SAME. (1)
- 10.4.3 Explain the answer to QUESTION 10.4.2. (2)

[14]

TOTAL: 150

**DATA FOR PHYSICAL SCIENCES GRADE 12
PAPER 1 (PHYSICS)**

**GEGEWENS VIR FISIESTE WETENSAPPE GRAAD 12
VRAESTEL 1 (FISIKA)**

TABLE 1: PHYSICAL CONSTANTS/TABEL 1: FISIESTE KONSTANTES

NAME/NAAM	SYMBOL/SIMBOOL	VALUE/WAARDE
Acceleration due to gravity <i>Swaartekragversnelling</i>	g	9,8 m·s ⁻²
Universal gravitational constant <i>Universele gravitasiekonstant</i>	G	6,67 x 10 ⁻¹¹ N·m ² ·kg ⁻²
Speed of light in a vacuum <i>Spoed van lig in 'n vakuum</i>	c	3,0 x 10 ⁸ m·s ⁻¹
Planck's constant <i>Planck se konstante</i>	h	6,63 x 10 ⁻³⁴ J·s
Coulomb's constant <i>Coulomb se konstante</i>	k	9,0 x 10 ⁹ N·m ² ·C ⁻²
Charge on electron <i>Lading op elektron</i>	e ⁻	-1,6 x 10 ⁻¹⁹ C
Electron mass <i>Elektronmassa</i>	m _e	9,11 x 10 ⁻³¹ kg
Mass of Earth <i>Massa van Aarde</i>	M	5,98 x 10 ²⁴ kg
Radius of Earth <i>Straal van Aarde</i>	R _E	6,38 x 10 ³ km

TABLE 2: FORMULAE/TABEL 2: FORMULES

MOTION/BEWEGING

$v_f = v_i + a \Delta t$	$\Delta x = v_i \Delta t + \frac{1}{2} a \Delta t^2$ or/of $\Delta y = v_i \Delta t + \frac{1}{2} a \Delta t^2$
$v_f^2 = v_i^2 + 2a\Delta x$ or/of $v_f^2 = v_i^2 + 2a\Delta y$	$\Delta x = \left(\frac{v_i + v_f}{2} \right) \Delta t$ or/of $\Delta y = \left(\frac{v_i + v_f}{2} \right) \Delta t$

FORCE/KRAG

$F_{\text{net}} = ma$	$p = mv$
$f_s^{\text{max}} = \mu_s N$	$f_k = \mu_k N$
$F_{\text{net}} \Delta t = \Delta p$ $\Delta p = mv_f - mv_i$	$w = mg$
$F = G \frac{m_1 m_2}{d^2}$ or/of $F = G \frac{m_1 m_2}{r^2}$	$g = G \frac{M}{d^2}$ or/of $g = G \frac{M}{r^2}$

WORK, ENERGY AND POWER/ARBEID, ENERGIE EN DRYWING

$W = F \Delta x \cos \theta$	$U = mgh$ or/of $E_p = mgh$
$K = \frac{1}{2} mv^2$ or/of $E_k = \frac{1}{2} mv^2$	$W_{\text{net}} = \Delta K$ or/of $W_{\text{net}} = \Delta E_k$ $\Delta K = K_f - K_i$ or/of $\Delta E_k = E_{kf} - E_{ki}$
$W_{\text{nc}} = \Delta K + \Delta U$ or/of $W_{\text{nc}} = \Delta E_k + \Delta E_p$	$P = \frac{W}{\Delta t}$
$P_{\text{av}} = F v_{\text{av}}$ / $P_{\text{gemid}} = F v_{\text{gemid}}$	

WAVES, SOUND AND LIGHT/GOLWE, KLANK EN LIG

$v = f \lambda$	$T = \frac{1}{f}$
$f_L = \frac{v \pm v_L}{v \pm v_s} f_s$ $f_L = \frac{v \pm v_L}{v \pm v_b} f_b$	$E = hf$ or /of $E = h \frac{c}{\lambda}$
$E = W_o + E_{k(\text{max})}$ or/of $E = W_o + K_{\text{max}}$ where/waar	
$E = hf$ and/en $W_o = hf_o$ and/en $E_{k(\text{max})} = \frac{1}{2} mv_{\text{max}}^2$ or/of $K_{\text{max}} = \frac{1}{2} mv_{\text{max}}^2$	

ELECTROSTATICS/ELEKTROSTATIKA

$F = \frac{kQ_1Q_2}{r^2}$	$E = \frac{kQ}{r^2}$
$V = \frac{W}{q}$	$E = \frac{F}{q}$
$n = \frac{Q}{e}$ or / of $n = \frac{Q}{q_e}$	

ELECTRIC CIRCUITS/ELEKTRIESE STROOMBANE

$R = \frac{V}{I}$	emf $\mathcal{E} = I(R + r)$ emk $\mathcal{E} = I(R + r)$
$R_s = R_1 + R_2 + \dots$ $\frac{1}{R_p} = \frac{1}{R_1} + \frac{1}{R_2} + \dots$	$q = I \Delta t$
$W = Vq$ $W = VI \Delta t$ $W = I^2 R \Delta t$ $W = \frac{V^2 \Delta t}{R}$	$P = \frac{W}{\Delta t}$ $P = VI$ $P = I^2 R$ $P = \frac{V^2}{R}$

ALTERNATING CURRENT/WISSELSTROOM

$I_{\text{rms}} = \frac{I_{\text{max}}}{\sqrt{2}}$ / $I_{\text{wgk}} = \frac{I_{\text{maks}}}{\sqrt{2}}$	$P_{\text{av}} = V_{\text{rms}} I_{\text{rms}}$ / $P_{\text{gemiddeld}} = V_{\text{wgk}} I_{\text{wgk}}$
$V_{\text{rms}} = \frac{V_{\text{max}}}{\sqrt{2}}$ / $V_{\text{wgk}} = \frac{V_{\text{maks}}}{\sqrt{2}}$	$P_{\text{av}} = I_{\text{rms}}^2 R$ / $P_{\text{gemiddeld}} = I_{\text{wgk}}^2 R$
	$P_{\text{av}} = \frac{V_{\text{rms}}^2}{R}$ / $P_{\text{gemiddeld}} = \frac{V_{\text{wgk}}^2}{R}$