



basic education

Department:
Basic Education
REPUBLIC OF SOUTH AFRICA

**NATIONAL
SENIOR CERTIFICATE**

GRADE 12

PHYSICAL SCIENCES: PHYSICS (P1)

FEBRUARY/MARCH 2017

MARKS: 150

TIME: 3 hours

This question paper consists of 16 pages and 3 data sheets.

INSTRUCTIONS AND INFORMATION

1. Write your centre number and examination number in the appropriate spaces on the ANSWER BOOK.
2. This question paper consists of 10 questions. Answer ALL the questions in the ANSWER BOOK.
3. Start EACH question on a NEW page in the ANSWER BOOK.
4. Number the answers correctly according to the numbering system used in this question paper.
5. Leave ONE line between two subquestions, for example between QUESTION 2.1 and QUESTION 2.2.
6. You may use a non-programmable calculator.
7. You may use appropriate mathematical instruments.
8. You are advised to use the attached DATA SHEETS.
9. Show ALL formulae and substitutions in ALL calculations.
10. Round off your final numerical answers to a minimum of TWO decimal places.
11. Give brief motivations, discussions et cetera where required.
12. Write neatly and legibly.

QUESTION 1: MULTIPLE-CHOICE QUESTIONS

Various options are provided as possible answers to the following questions. Write down the question number (1.1–1.10), choose the answer and make a cross (X) over the letter (A–D) of your choice in the ANSWER BOOK.

EXAMPLE:

1.11	A	B	C	D
------	---	---	---	--------------

1.1 According to Newton's Second Law of Motion, the acceleration of an object is ...

- A independent of its mass.
- B always equal to its mass.
- C directly proportional to its mass.
- D inversely proportional to its mass.

(2)

1.2 The diagram below shows three blocks, **P**, **Q** and **R**, suspended from a ceiling. The blocks are *identical*, *stationary* and have the *same mass* but are at different heights above the ground.

The connecting strings are massless and inextensible. The tensions in the strings attached to blocks **P**, **Q** and **R** are T_P , T_Q and T_R respectively.

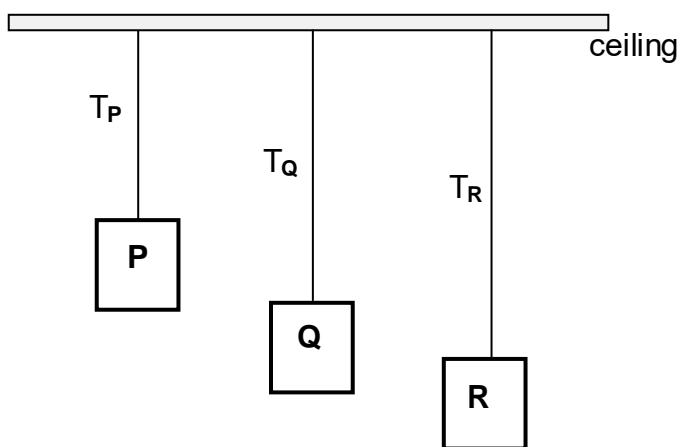

Which ONE of the following statements about the tensions is CORRECT?

- A $T_P > T_Q > T_R$
- B $T_P < T_Q < T_R$
- C $T_P = T_Q = T_R$
- D $T_P > T_Q$ and $T_Q < T_R$

(2)

- 1.3 A ball is projected vertically upwards from the ground. It returns to the ground, makes an elastic collision with the ground and then bounces to a maximum height. Ignore air resistance.

Which ONE of the following velocity-time graphs CORRECTLY describes the motion of the ball?

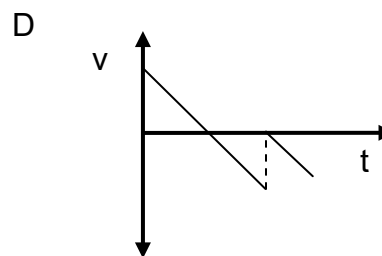
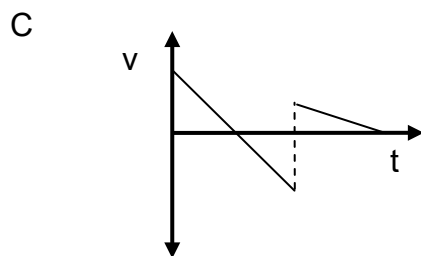
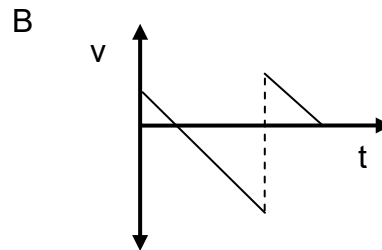
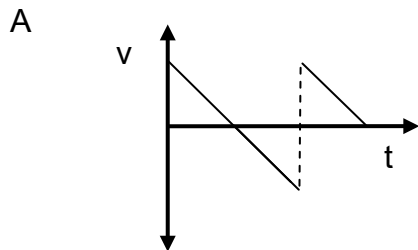

(2)

- 1.4 When the velocity of a moving object is *doubled*, the ...

- A net work done by the object is doubled.
- B kinetic energy of the object is doubled.
- C potential energy of the object is doubled.
- D linear momentum of the object is doubled.

(2)

- 1.5 The net work required to stop a moving object is equal to the ...

- A inertia of the object.
- B change in kinetic energy of the object.
- C change in momentum of the object.
- D change in impulse of the object.

(2)

- 1.6 A stationary observer is listening to the sound coming from a sound source. The listener hears a sound of a lower pitch when compared to that produced by the source.

What can you conclude about the source from this observation?

- A The source is at rest.
- B The source is moving towards the listener.
- C The source is moving away from the listener.
- D There is an obstacle between the source and the listener. (2)

- 1.7 Two charged particles are placed a distance, r , apart. The electrostatic force exerted by one charged particle on the other is F_E

Which ONE of the graphs below CORRECTLY represents the relationship between the electrostatic force, F_E , and the square of the distance, r^2 , between the two charges?

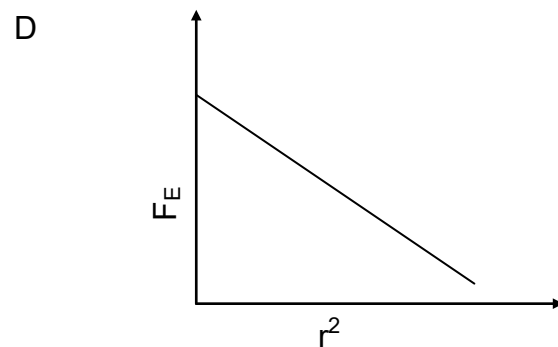
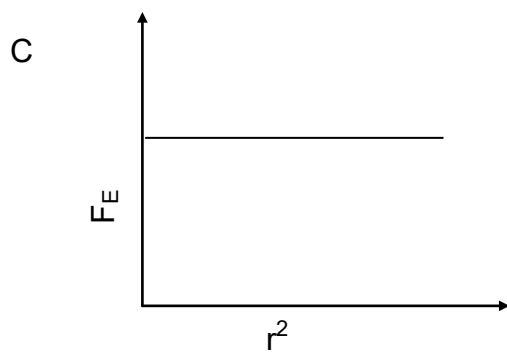
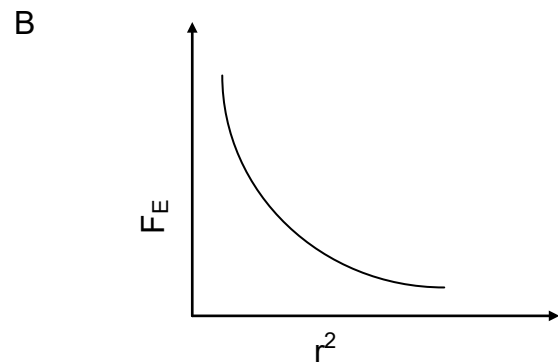
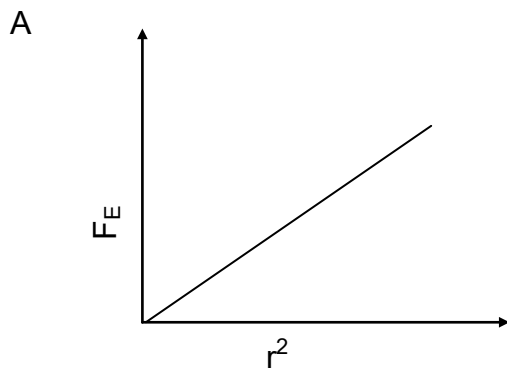

(2)

- 1.8 In the circuit diagram below, the resistance of resistor R_1 is TWICE the resistance of resistor R_2 .

The two resistors are connected in series and identical high-resistance voltmeters are connected across each resistor.

The readings on the voltmeters are V_1 and V_2 respectively.

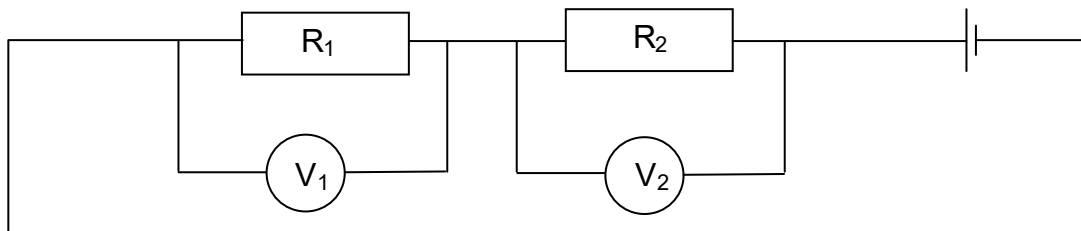

Which ONE of the following statements concerning the voltmeter readings is CORRECT?

- A $V_1 = 2V_2$
- B $V_1 = \frac{1}{2}V_2$
- C $V_1 = \frac{1}{4}V_2$
- D $2V_1 = V_2$ (2)
- 1.9 In a DC generator the current to the external circuit is delivered through the ...
- A coils.
- B battery.
- C slip rings.
- D split rings (commutators). (2)
- 1.10 In an experiment on the photoelectric effect, the frequency of the incident light is high enough to cause the removal of electrons from the surface of the metal.
- The number of electrons ejected from the metal surface is proportional to the ...
- A kinetic energy of the electrons.
- B number of incident photons.
- C work function of the metal.
- D frequency of the incident light. (2)

[20]

QUESTION 2 (Start on a new page.)

In the diagram below, a small object of mass 2 kg is sliding at a constant velocity of $1,5 \text{ m}\cdot\text{s}^{-1}$ down a rough plane inclined at 7° to the horizontal surface.

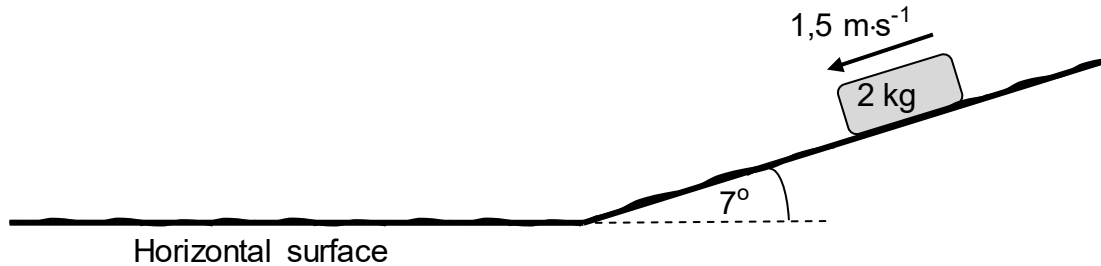

At the bottom of the plane, the object continues sliding onto the rough horizontal surface *and eventually comes to a stop*.

The coefficient of kinetic friction between the object and the surface is *the same for both the inclined surface and the horizontal surface*.

- 2.1 Write down the magnitude of the net force acting on the object. (1)
 - 2.2 Draw a labelled free-body diagram for the object while it is on the inclined plane. (3)
 - 2.3 Calculate the:
 - 2.3.1 Magnitude of the frictional force acting on the object while it is sliding down the inclined plane (3)
 - 2.3.2 Coefficient of kinetic friction between the object and the surfaces (3)
 - 2.3.3 Distance the object travels on the horizontal surface before it comes to a stop (5)
- [15]**

QUESTION 3 (Start on a new page.)

A hot-air balloon moves vertically downwards at a constant velocity of $1,2 \text{ m}\cdot\text{s}^{-1}$. When it reaches a height of 22 m from the ground, a ball is dropped from the balloon. Refer to the diagram below.

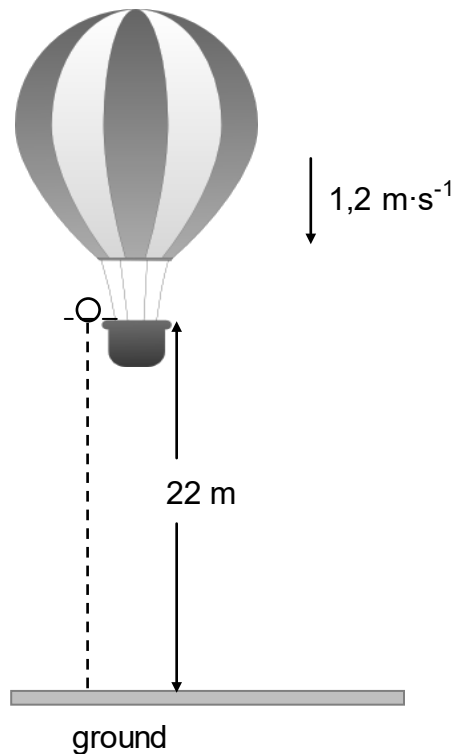

Assume that the dropping of the ball has no effect on the speed of the hot-air balloon. Ignore air friction for the motion of the ball.

3.1 Explain the term *projectile motion*. (2)

3.2 Is the hot-air balloon in free fall? Give a reason for the answer. (2)

3.3 Calculate the time it takes for the ball to hit the ground after it is dropped. (4)

When the ball lands on the ground, it is in contact with the ground for 0,3 s and then it bounces vertically upwards with a speed of $15 \text{ m}\cdot\text{s}^{-1}$.

3.4 Calculate how high the balloon is from the ground when the ball reaches its maximum height after the first bounce. (6)
[14]

QUESTION 4 (Start on a new page.)

4.1 Define the term *impulse* in words. (2)

4.2 The diagram below shows a gun mounted on a mechanical support which is fixed to the ground. The gun is capable of firing bullets rapidly in a horizontal direction.

Each bullet travels at a speed of $700 \text{ m}\cdot\text{s}^{-1}$ in an easterly direction when it leaves the gun.

(Take the initial velocity of a bullet, before being fired, as zero.)

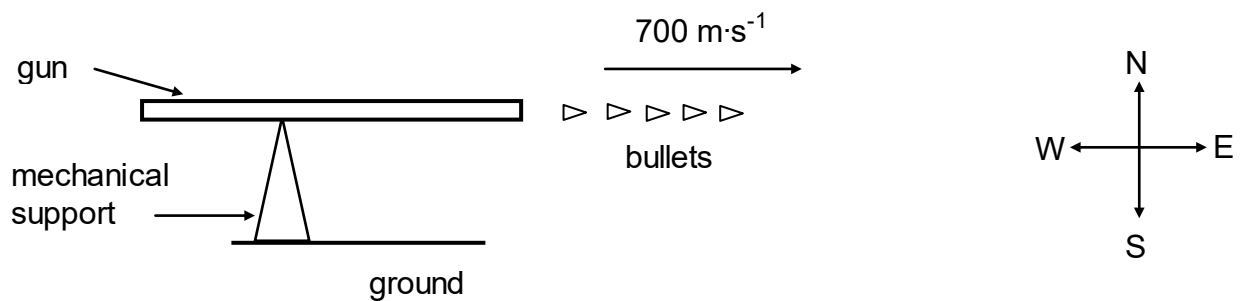

The gun fires 220 bullets per minute. The mass of each bullet is $0,03 \text{ kg}$.

Calculate the:

4.2.1 Magnitude of the momentum of each bullet when it leaves the gun (3)

4.2.2 The net average force that each bullet exerts on the gun (5)

4.3 Without any further calculation, write down the net average horizontal force that the mechanical support exerts on the gun. (2)
[12]

QUESTION 5 (Start on a new page.)

A lift arrangement comprises an electric motor, a cage and its counterweight. The counterweight moves vertically downwards as the cage moves upwards. The cage and counterweight move at the same constant speed. Refer to the diagram below.

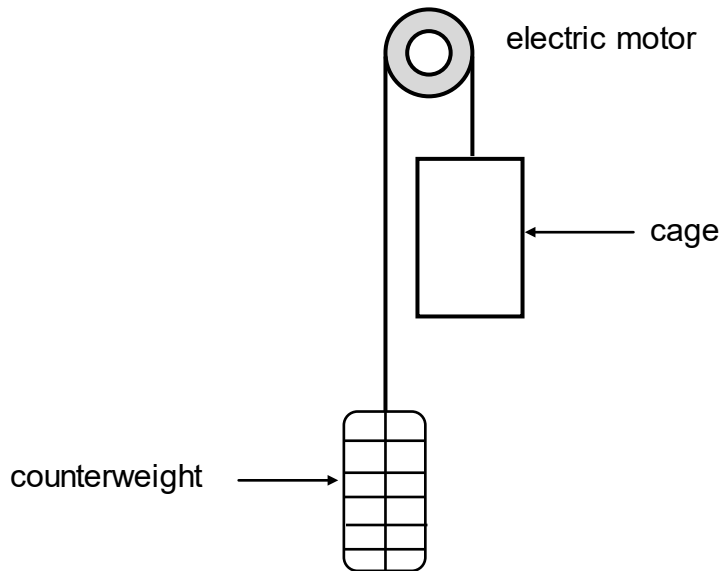

The cage, carrying passengers, moves vertically upwards at a constant speed, covering 55 m in 3 minutes. The counterweight has a mass of 950 kg. The total mass of the cage and passengers is 1 200 kg. The electric motor provides the power needed to operate the lift system. Ignore the effects of friction.

- 5.1 Define the term *power* in words. (2)
- 5.2 Calculate the work done by the:
- 5.2.1 Gravitational force on the cage (3)
- 5.2.2 Counterweight on the cage (2)
- 5.3 Calculate the average power required by the motor to operate the lift arrangement in 3 minutes. Assume that there are no energy losses due to heat and sound. (6)

[13]

QUESTION 6 (Start on a new page.)

6.1 A sound source is moving at constant velocity past a stationary observer. The frequency detected as the source approaches the observer is 2 600 Hz. The frequency detected as the source moves away from the observer is 1 750 Hz.

Take the speed of sound in air as $340 \text{ m}\cdot\text{s}^{-1}$.

6.1.1 Name the phenomenon that describes the apparent change in frequency detected by the observer. (1)

6.1.2 State ONE practical application of the phenomenon in QUESTION 6.1.1 in the field of medicine. (1)

6.1.3 Calculate the speed of the moving source. (6)

6.1.4 Will the observed frequency INCREASE, DECREASE or REMAIN THE SAME if the velocity of the source increased as it:

(a) Moves towards the observer (1)

(b) Moves away from the observer (1)

6.2 Spectral lines of star X at an observatory are observed to be *red shifted*.

6.2.1 Explain the term *red shifted* in terms of wavelength. (2)

6.2.2 Will the frequency of the light observed from the star INCREASE, DECREASE or REMAIN THE SAME? (1)

[13]

QUESTION 7 (Start on a new page.)

7.1 A metal sphere A, suspended from a wooden beam by means of a non-conducting string, has a charge of $+6 \mu\text{C}$.

7.1.1 Were electrons ADDED TO or REMOVED FROM the sphere to obtain this charge? Assume that the sphere was initially neutral. (1)

7.1.2 Calculate the number of electrons added to or removed from the sphere. (3)

7.2 Point charges Q_1 , Q_2 and Q_3 are arranged at the corners of a right-angled triangle, as shown in the diagram below.

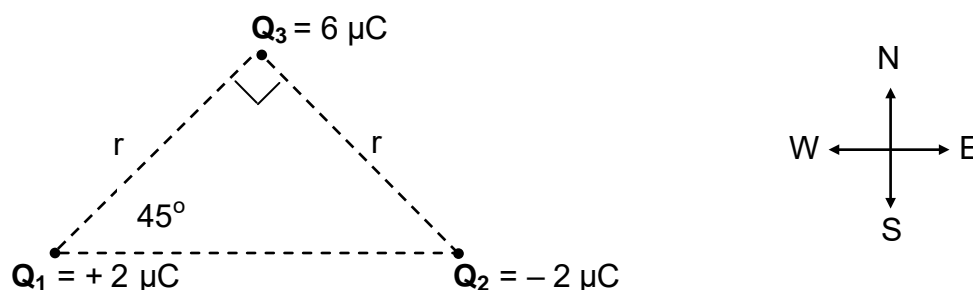

The charges on Q_1 and Q_2 are $+2 \mu\text{C}$ and $-2 \mu\text{C}$ respectively and the magnitude of the charge on Q_3 is $6 \mu\text{C}$.

The distance between Q_1 and Q_3 is r . The distance between Q_2 and Q_3 is also r .

The charge Q_3 experiences a resultant electrostatic force of $0,12 \text{ N}$ to the west.

7.2.1 Without calculation, identify the sign (positive or negative) on the charge Q_3 . (1)

7.2.2 Draw a vector diagram to show the electrostatic forces acting on Q_3 due to charges Q_1 and Q_2 respectively. (2)

7.2.3 Write down an expression, in terms of r , for the horizontal component of the electrostatic force exerted on Q_3 by Q_1 . (3)

7.2.4 Calculate the distance r . (4)

7.3 The magnitude of the electric field is $100 \text{ N}\cdot\text{C}^{-1}$ at a point which is $0,6 \text{ m}$ away from a point charge Q .

7.3.1 Define the term *electric field at a point* in words. (2)

7.3.2 Calculate the distance from point charge Q at which the magnitude of the electric field is $50 \text{ N}\cdot\text{C}^{-1}$. (5)

[21]

QUESTION 8 (Start on a new page).

- 8.1 In Circuit 1 below three identical light bulbs, **P**, **Q** and **R**, with the same resistance, are connected to a battery with emf ϵ and negligible internal resistance.

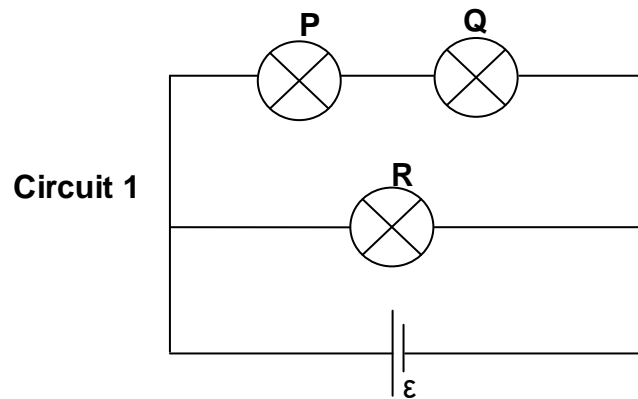

- 8.1.1 How does the brightness of bulb **P** compare with that of bulb **Q**?
Give a reason for the answer. (2)
- 8.1.2 How does the brightness of bulb **P** compare with that of bulb **R**?
Give a reason for the answer. (2)

A fourth, identical bulb **T**, with the same resistance as the other three, is connected to the circuit by means of an ordinary wire of negligible resistance, as shown in Circuit 2 below.

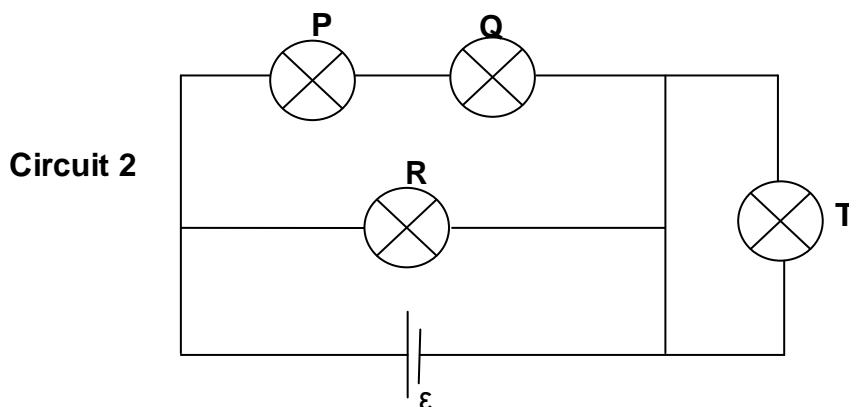

- 8.1.3 How does the brightness of bulb **T** compare with that of bulb **R**?
Give a reason for the answer. (2)

- 8.2 A battery with an emf of 20 V and an internal resistance of 1 Ω is connected to three resistors, as shown in the circuit below.

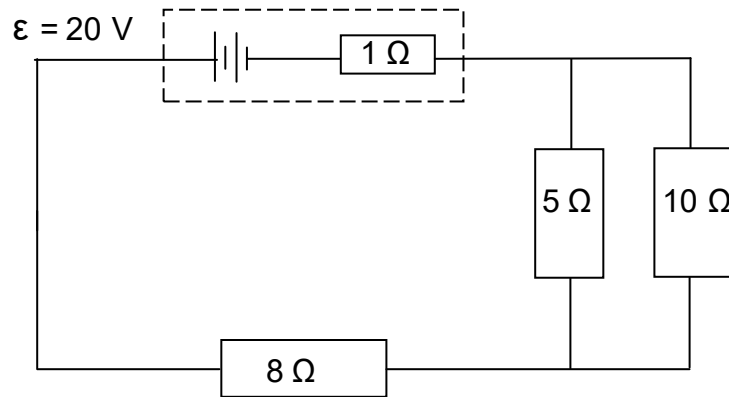

Calculate the:

- 8.2.1 Current in the 8Ω resistor (6)
- 8.2.2 Potential difference across the 5Ω resistor (4)
- 8.2.3 Total power supplied by the battery (3)
- [19]**

QUESTION 9 (Start on a new page.)

The diagram below shows a simplified version of an AC generator.

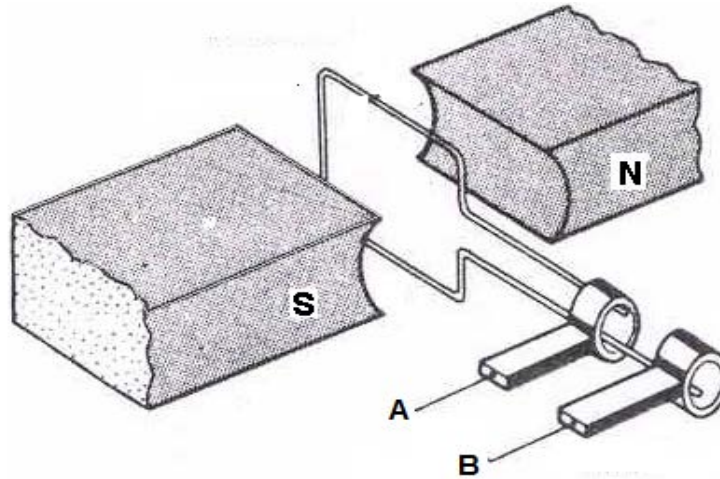

9.1 Name the component in this arrangement that makes it different from a DC generator. (1)

9.2 Sketch a graph of induced emf versus time for TWO complete rotations of the coil. (2)

A practical version of the generator above has a large number of turns of the coil and it produces an rms potential difference of 240 V.

9.3 State TWO ways in which the induced emf can be increased. (2)

9.4 Define the term *root mean square (rms) value* of an AC potential difference. (2)

9.5 The practical version of the generator above is connected across an appliance rated at 1 500 W.

Calculate the rms current passing through the appliance. (3)
[10]

QUESTION 10 (Start on a new page.)

The graph below is obtained for an experiment on the photoelectric effect using different frequencies of light and a given metal plate.

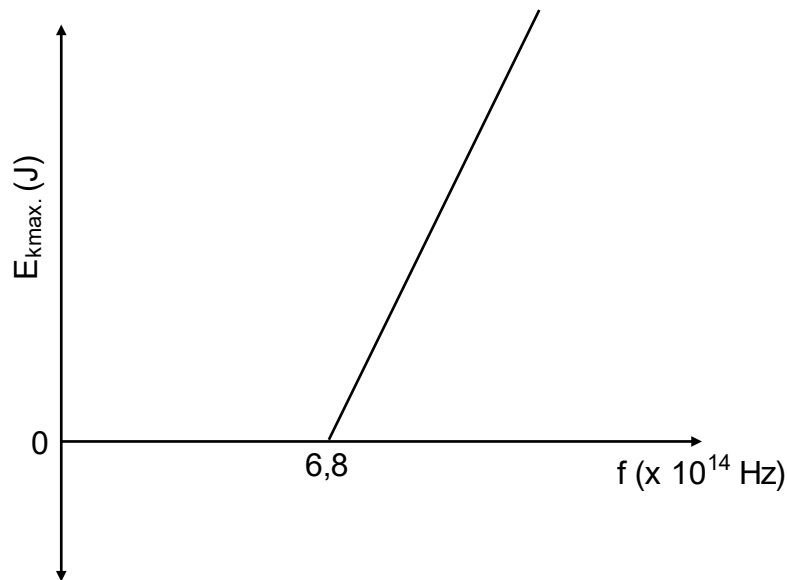

The threshold frequency for the metal is $6,8 \times 10^{14}$ Hz.

10.1 Define the term *threshold frequency*. (2)

In the experiment, the brightness of the light incident on the metal surface is increased.

10.2 State how this change will influence the speed of the photoelectrons emitted.

Choose from INCREASES, DECREASES or REMAINS UNCHANGED. (1)

10.3 Show by means of a calculation whether the photoelectric effect will be OBSERVED or NOT OBSERVED, if monochromatic light with a wavelength of 6×10^{-7} m is used in this experiment. (5)

One of the radiations used in this experiment has a frequency of $7,8 \times 10^{14}$ Hz.

10.4 Calculate the maximum speed of an ejected photoelectron. (5)
[13]

TOTAL: 150

**DATA FOR PHYSICAL SCIENCES GRADE 12
PAPER 1 (PHYSICS)**

**GEGEWENS VIR FISIESTE WETENSKAPPE GRAAD 12
VRAESTEL 1 (FISIKA)**

TABLE 1: PHYSICAL CONSTANTS/TABEL 1: FISIESTE KONSTANTES

NAME/NAAM	SYMBOL/SIMBOOL	VALUE/WAARDE
Acceleration due to gravity <i>Swaartekragversnelling</i>	g	9,8 m·s ⁻²
Universal gravitational constant <i>Universele gravitasiekonstant</i>	G	6,67 x 10 ⁻¹¹ N·m ² ·kg ⁻²
Speed of light in a vacuum <i>Spoed van lig in 'n vakuum</i>	c	3,0 x 10 ⁸ m·s ⁻¹
Planck's constant <i>Planck se konstante</i>	h	6,63 x 10 ⁻³⁴ J·s
Coulomb's constant <i>Coulomb se konstante</i>	k	9,0 x 10 ⁹ N·m ² ·C ⁻²
Charge on electron <i>Lading op elektron</i>	e	1,6 x 10 ⁻¹⁹ C
Electron mass <i>Elektronmassa</i>	m _e	9,11 x 10 ⁻³¹ kg
Mass of the Earth <i>Massa van die Aarde</i>	M	5,98 x 10 ²⁴ kg
Radius of the Earth <i>Radius van die Aarde</i>	R _E	6,38 x 10 ⁶ m

TABLE 2: FORMULAE/TABEL 2: FORMULES

MOTION/BEWEGING

$v_f = v_i + a \Delta t$	$\Delta x = v_i \Delta t + \frac{1}{2} a \Delta t^2$ or/of $\Delta y = v_i \Delta t + \frac{1}{2} a \Delta t^2$
$v_f^2 = v_i^2 + 2a\Delta x$ or/of $v_f^2 = v_i^2 + 2a\Delta y$	$\Delta x = \left(\frac{v_i + v_f}{2} \right) \Delta t$ or/of $\Delta y = \left(\frac{v_i + v_f}{2} \right) \Delta t$

FORCE/KRAG

$F_{\text{net}} = ma$	$p = mv$
$f_s^{\text{max}} = \mu_s N$	$f_k = \mu_k N$
$F_{\text{net}} \Delta t = \Delta p$ $\Delta p = mv_f - mv_i$	$w = mg$
$F = G \frac{m_1 m_2}{d^2}$ or/of $F = G \frac{m_1 m_2}{r^2}$	$g = G \frac{M}{d^2}$ or/of $g = G \frac{M}{r^2}$

WORK, ENERGY AND POWER/ARBEID, ENERGIE EN DRYWING

$W = F \Delta x \cos \theta$	$U = mgh$ or/of $E_p = mgh$
$K = \frac{1}{2} mv^2$ or/of $E_k = \frac{1}{2} mv^2$	$W_{\text{net}} = \Delta K$ or/of $W_{\text{net}} = \Delta E_k$ $\Delta K = K_f - K_i$ or/of $\Delta E_k = E_{kf} - E_{ki}$
$W_{\text{nc}} = \Delta K + \Delta U$ or/of $W_{\text{nc}} = \Delta E_k + \Delta E_p$	$P = \frac{W}{\Delta t}$
$P_{\text{ave}} = Fv_{\text{ave}}$ / $P_{\text{gemid}} = Fv_{\text{gemid}}$	

WAVES, SOUND AND LIGHT/GOLWE, KLANK EN LIG

$v = f \lambda$	$T = \frac{1}{f}$
$f_L = \frac{v \pm v_L}{v \pm v_s} f_s$ $f_L = \frac{v \pm v_L}{v \pm v_b} f_b$	$E = hf$ or/of $E = h \frac{c}{\lambda}$
$E = W_o + E_{k(\text{max})}$ or/of $E = W_o + K_{\text{max}}$ where/waar	
$E = hf$ and/en $W_o = hf_0$ and/en $E_{k(\text{max})} = \frac{1}{2} mv_{\text{max}}^2$ or/of $K_{\text{max}} = \frac{1}{2} mv_{\text{max}}^2$	

ELECTROSTATICS/ELEKTROSTATIKA

$F = \frac{kQ_1Q_2}{r^2}$	$E = \frac{kQ}{r^2}$
$V = \frac{W}{q}$	$E = \frac{F}{q}$
$n = \frac{Q}{e}$ or / of $n = \frac{Q}{q_e}$	

ELECTRIC CIRCUITS/ELEKTRIESE STROOMBANE

$R = \frac{V}{I}$	emf (ϵ) = $I(R + r)$ emk (ϵ) = $I(R + r)$
$R_s = R_1 + R_2 + \dots$ $\frac{1}{R_p} = \frac{1}{R_1} + \frac{1}{R_2} + \dots$	$q = I \Delta t$
$W = Vq$ $W = VI\Delta t$ $W = I^2R\Delta t$ $W = \frac{V^2\Delta t}{R}$	$P = \frac{W}{\Delta t}$ $P = VI$ $P = I^2R$ $P = \frac{V^2}{R}$

ALTERNATING CURRENT/WISSELSTROOM

$I_{rms} = \frac{I_{max}}{\sqrt{2}}$ / $I_{wgk} = \frac{I_{maks}}{\sqrt{2}}$	$P_{ave} = V_{rms} I_{rms}$ / $P_{gemiddeld} = V_{wgk} I_{wgk}$
$V_{rms} = \frac{V_{max}}{\sqrt{2}}$ / $V_{wgk} = \frac{V_{maks}}{\sqrt{2}}$	$P_{ave} = I_{rms}^2 R$ / $P_{gemiddeld} = I_{wgk}^2 R$
	$P_{ave} = \frac{V_{rms}^2}{R}$ / $P_{gemiddeld} = \frac{V_{wgk}^2}{R}$