



basic education

Department:
Basic Education
REPUBLIC OF SOUTH AFRICA

NATIONAL SENIOR CERTIFICATE

GRADE 12

PHYSICAL SCIENCES: PHYSICS (P1)

NOVEMBER 2015

MARKS: 150

TIME: 3 hours

This question paper consists of 17 pages, 3 data sheets and 1 answer sheet.

INSTRUCTIONS AND INFORMATION

1. Write your centre number and examination number in the appropriate spaces on the ANSWER BOOK and ANSWER SHEET.
2. This question paper consists of 11 questions. Answer QUESTION 11.2 on the attached ANSWER SHEET. Answer ALL the other questions in the ANSWER BOOK.
3. Start EACH question on a NEW page in the ANSWER BOOK.
4. Number the answers correctly according to the numbering system used in this question paper.
5. Leave ONE line between two subquestions, for example between QUESTION 2.1 and QUESTION 2.2.
6. You may use a non-programmable calculator.
7. You may use appropriate mathematical instruments.
8. You are advised to use the attached DATA SHEETS.
9. Show ALL formulae and substitutions in ALL calculations.
10. Round off your final numerical answers to a minimum of TWO decimal places.
11. Give brief motivations, discussions et cetera where required.
12. Write neatly and legibly.

QUESTION 1: MULTIPLE-CHOICE QUESTIONS

Four options are provided as possible answers to the following questions. Each question has only ONE correct answer. Choose the answer and write only the letter (A–D) next to the question number (1.1–1.10) in the ANSWER BOOK, for example 1.11 E.

- 1.1 Two forces, F_1 and F_2 , are applied on a crate lying on a frictionless, horizontal surface, as shown in the diagram below.

The magnitude of force F_1 is greater than that of force F_2 .

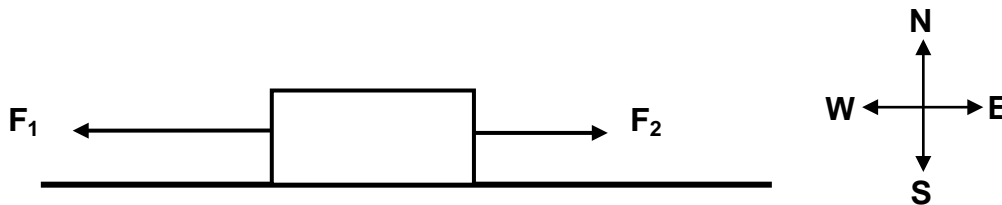

The crate will ...

- A accelerate towards the east.
 - B accelerate towards the west.
 - C move at a constant speed towards the east.
 - D move at a constant speed towards the west. (2)
- 1.2 A person stands on a bathroom scale that is calibrated in newton, in a stationary elevator. The reading on the bathroom scale is W .

The elevator now moves with a constant upward acceleration of $\frac{1}{4}g$, where g is the gravitational acceleration.

What will the reading on the bathroom scale be now?

- A $\frac{1}{4}W$
- B $\frac{3}{4}W$
- C W
- D $\frac{5}{4}W$ (2)

1.3 Which ONE of the graphs below correctly represents the relationship between the kinetic energy (K) of a free-falling object and its speed (v)?

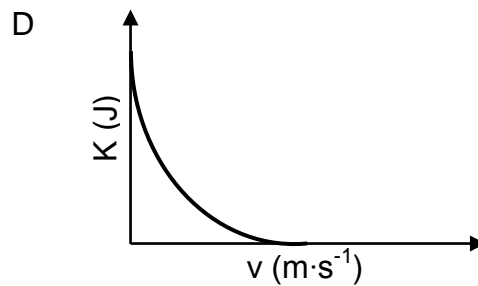
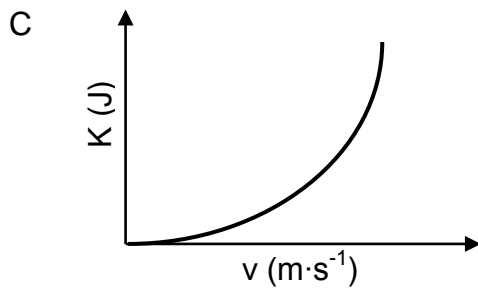
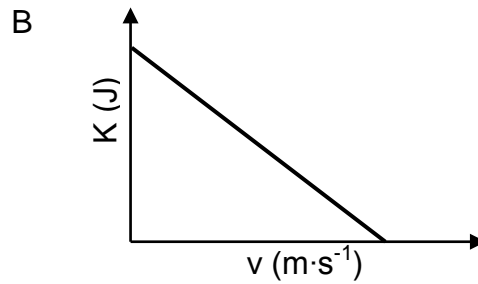
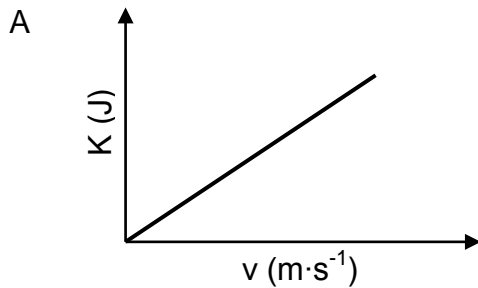

(2)

1.4 The simplified diagram below shows a rocket that has been fired horizontally, accelerating to the west.

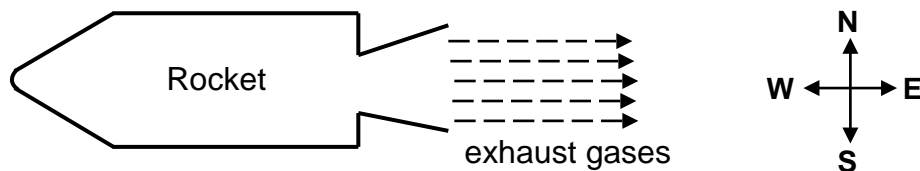

Which ONE of the statements below best explains why the rocket accelerates?

- A The speed of the exhaust gases is smaller than the speed of the rocket.
- B The pressure of the atmosphere at the back of the rocket is less than at the front.
- C The air outside the rocket exerts a greater force on the back of the rocket than at the front.
- D The rocket pushes the exhaust gases to the east and the exhaust gases push the rocket to the west.

(2)

- 1.5 The graph below represents the relationship between the work done on an object and the time taken for this work to be done.

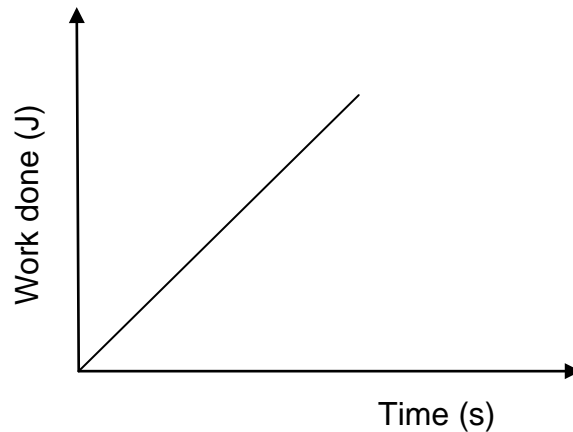

The gradient of the graph represents the ...

- A power.
 B momentum.
 C kinetic energy.
 D potential energy. (2)
- 1.6 A line emission spectrum is formed when an excited atom moves from a ...
 A higher to a lower energy level and releases energy.
 B higher to a lower energy level and absorbs energy.
 C lower to a higher energy level and releases energy.
 D lower to a higher energy level and absorbs energy. (2)
- 1.7 Two charged spheres of magnitudes $2Q$ and Q respectively are placed a distance r apart on insulating stands.
 If the sphere of charge Q experiences a force F to the east, then the sphere of charge $2Q$ will experience a force ...
 A F to the west.
 B F to the east.
 C $2F$ to the west.
 D $2F$ to the east. (2)

- 1.8 The four resistors **P**, **Q**, **R** and **T** in the circuit below are identical. The cell has an emf ε and negligible internal resistance. The switch is initially CLOSED.

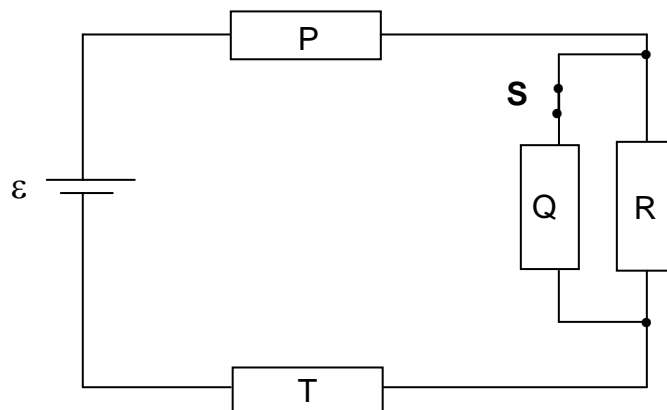

Switch **S** is now OPENED. Which ONE of the following combinations of changes will occur in **P**, **R** and **T**?

	CURRENT IN P	CURRENT IN R	CURRENT IN T
A	Decreases	Remains the same	Decreases
B	Increases	Remains the same	Increases
C	Increases	Increases	Increases
D	Decreases	Increases	Decreases

(2)

- 1.9 A DC current passes through a rectangular wire loop OPQR placed between two pole pieces of a magnet, as shown below.

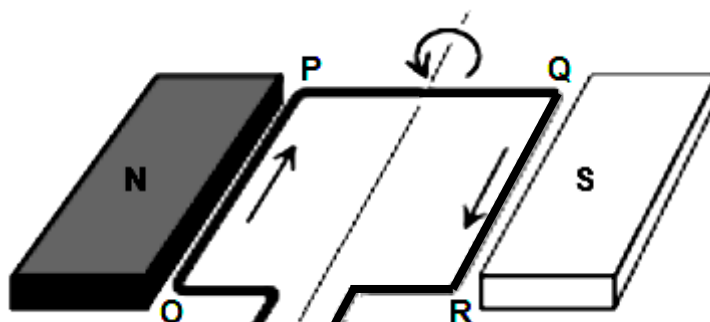

Which TWO segments of the loop will experience an electromagnetic force when the loop is in the position above?

- A OP and PQ
- B QR and RO
- C OP and QR
- D RO and OP

(2)

1.10 When light of a certain wavelength is incident on a metal surface, no electrons are ejected. Which ONE of the following changes may result in electrons being ejected from the metal surface?

- A Increase the intensity of the light.
- B Use light with a much shorter wavelength.
- C Use metal with a larger work function.
- D Increase the surface area of the metal.

(2)
[20]

QUESTION 2 (Start on a new page.)

- 2.1 Two blocks of mass M kg and 2,5 kg respectively are connected by a light, inextensible string. The string runs over a light, frictionless pulley, as shown in the diagram below.

The blocks are **stationary**.

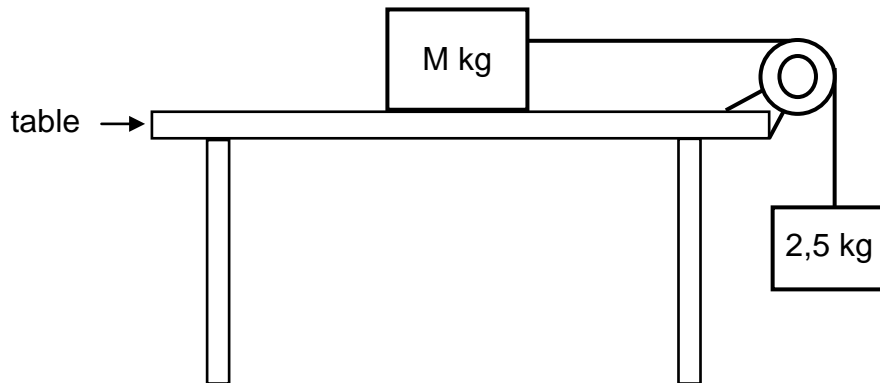

- 2.1.1 State Newton's THIRD law in words. (2)

- 2.1.2 Calculate the tension in the string. (3)

The coefficient of static friction (μ_s) between the unknown mass M and the surface of the table is 0,2.

- 2.1.3 Calculate the minimum value of M that will prevent the blocks from moving. (5)

The block of unknown mass M is now replaced with a block of mass 5 kg. The 2,5 kg block now accelerates downwards. The coefficient of kinetic friction (μ_k) between the 5 kg block and the surface of the table is 0,15.

- 2.1.4 Calculate the magnitude of the acceleration of the 5 kg block. (5)

- 2.2 A small hypothetical planet X has a mass of $6,5 \times 10^{20}$ kg and a radius of 550 km.

Calculate the gravitational force (weight) that planet X exerts on a 90 kg rock on this planet's surface.

(4)
[19]

QUESTION 3 (Start on a new page.)

Ball **A** is projected vertically upwards at a velocity of $16 \text{ m}\cdot\text{s}^{-1}$ from the ground. Ignore the effects of air resistance. **Use the ground as zero reference.**

3.1 Calculate the time taken by ball **A** to return to the ground. (4)

3.2 Sketch a velocity-time graph for ball **A**.

Show the following on the graph:

- (a) Initial velocity of ball **A**
- (b) Time taken to reach the highest point of the motion
- (c) Time taken to return to the ground (3)

ONE SECOND after ball **A** is projected upwards, a second ball, **B**, is thrown vertically downwards at a velocity of $9 \text{ m}\cdot\text{s}^{-1}$ from a balcony 30 m above the ground. Refer to the diagram below.

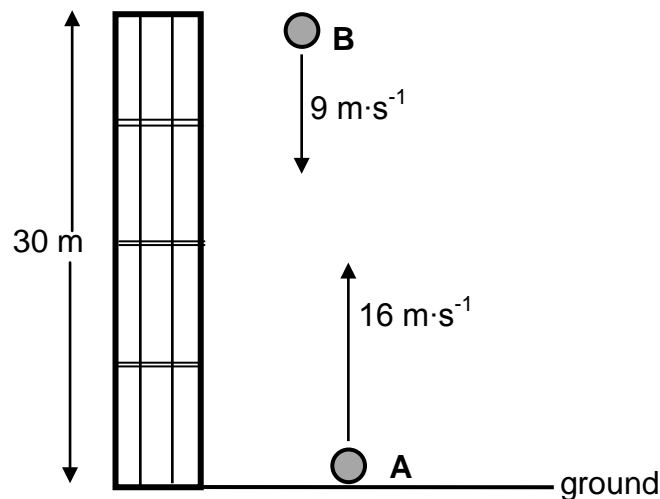

3.3 Calculate how high above the ground ball **A** will be at the instant the two balls pass each other. (6)
[13]

QUESTION 4 (Start on a new page.)

A bullet of mass 20 g is fired from a stationary rifle of mass 3 kg. Assume that the bullet moves horizontally. Immediately after firing, the rifle recoils (moves back) with a velocity of $1,4 \text{ m}\cdot\text{s}^{-1}$.

- 4.1 Calculate the speed at which the bullet leaves the rifle. (4)

The bullet strikes a stationary 5 kg wooden block **fixed** to a flat, horizontal table. The bullet is brought to rest after travelling a distance of 0,4 m **into the block**. Refer to the diagram below.

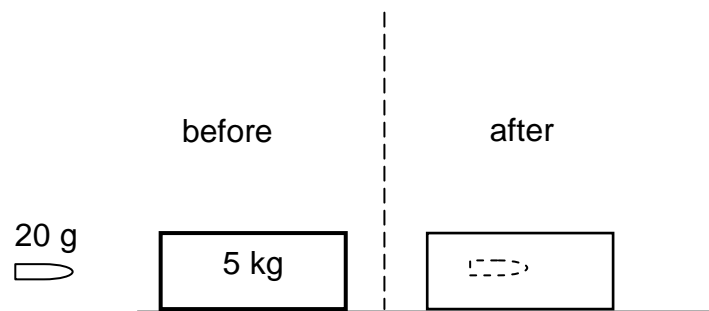

- 4.2 Calculate the magnitude of the average force exerted by the block on the bullet. (5)
- 4.3 How does the magnitude of the force calculated in QUESTION 4.2 compare to the magnitude of the force exerted by the bullet on the block? Write down only LARGER THAN, SMALLER THAN or THE SAME. (1)

[10]

QUESTION 5 (Start on a new page.)

The track for a motorbike race consists of a straight, horizontal section that is 800 m long.



A participant, such as the one in the picture above, rides at a certain average speed and completes the 800 m course in 75 s. To maintain this speed, a constant driving force of 240 N acts on the motorbike.

5.1 Calculate the average power developed by the motorbike for this motion. (3)

Another person practises on the same motorbike on a track with an incline. Starting from rest, the person rides a distance of 450 m up the incline which has a vertical height of 5 m, as shown below.

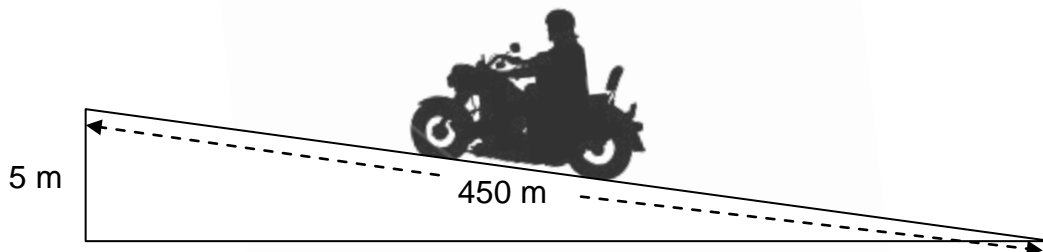

The total frictional force acting on the motorbike is 294 N. The combined mass of rider and motorbike is 300 kg. The average driving force on the motorbike as it moves up the incline is 350 N. Consider the motorbike and rider as a single system.

5.2 Draw a labelled free-body diagram for the motorbike-rider system on the incline. (4)

5.3 State the WORK-ENERGY theorem in words. (2)

5.4 Use energy principles to calculate the speed of the motorbike at the end of the 450 m ride. (6)
[15]

QUESTION 6 (Start on a new page.)

- 6.1 The data below was obtained during an investigation into the relationship between the different velocities of a moving sound source and the frequencies detected by a stationary listener for **each** velocity. The effect of wind was ignored in this investigation.

Experiment number	1	2	3	4
Velocity of the sound source ($\text{m}\cdot\text{s}^{-1}$)	0	10	20	30
Frequency (Hz) of the sound detected by the stationary listener	900	874	850	827

- 6.1.1 Write down the dependent variable for this investigation. (1)
- 6.1.2 State the Doppler effect in words. (2)
- 6.1.3 Was the sound source moving TOWARDS or AWAY FROM the listener? Give a reason for the answer. (2)
- 6.1.4 Use the information in the table to calculate the speed of sound during the investigation. (5)
- 6.2 The spectral lines of a distant star are shifted towards the longer wavelengths of light. Is the star moving TOWARDS or AWAY FROM the Earth? (1)
- [11]**

QUESTION 7 (Start on a new page.)

A very small graphite-coated sphere **P** is rubbed with a cloth. It is found that the sphere acquires a charge of $+ 0,5 \mu\text{C}$.

- 7.1 Calculate the number of electrons removed from sphere **P** during the charging process. (3)

Now the charged sphere **P** is suspended from a light, inextensible string. Another sphere, **R**, with a charge of $- 0,9 \mu\text{C}$, on an insulated stand, is brought close to sphere **P**. As a result sphere **P** moves to a position where it is 20 cm from sphere **R**, as shown below. The system is in equilibrium and the angle between the string and the vertical is 7° .

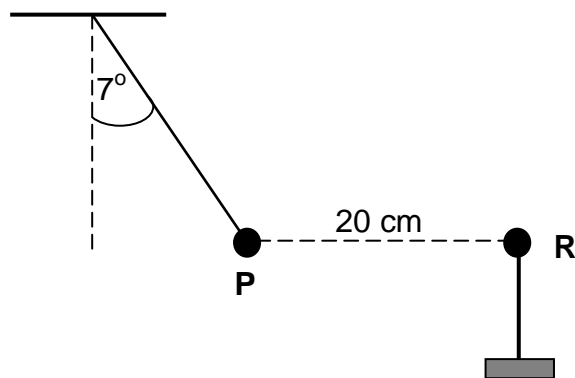

- 7.2 Draw a labelled free-body diagram showing ALL the forces acting on sphere **P**. (3)
- 7.3 State Coulomb's law in words. (2)
- 7.4 Calculate the magnitude of the tension in the string. (5)
- [13]**

QUESTION 8 (Start on a new page.)

Two charged particles, Q_1 and Q_2 , are placed 0,4 m apart along a straight line. The charge on Q_1 is $+ 2 \times 10^{-5}$ C, and the charge on Q_2 is $- 8 \times 10^{-6}$ C. Point X is 0,25 m east of Q_1 , as shown in the diagram below.

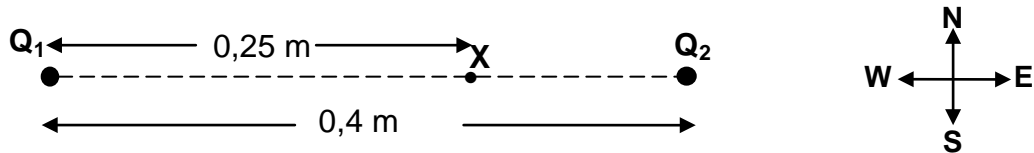

Calculate the:

8.1 Net electric field at point X due to the two charges (6)

8.2 Electrostatic force that a $- 2 \times 10^{-9}$ C charge will experience at point X (4)

The $- 2 \times 10^{-9}$ C charge is replaced with a charge of $- 4 \times 10^{-9}$ C at point X .

8.3 **Without any further calculation**, determine the magnitude of the force that the $- 4 \times 10^{-9}$ C charge will experience at point X . (1)
[11]

QUESTION 9 (Start on a new page.)

A battery with an internal resistance of $1\ \Omega$ and an unknown emf (ε) is connected in a circuit, as shown below. A high-resistance voltmeter (V) is connected across the battery. A_1 and A_2 represent ammeters of negligible resistance.

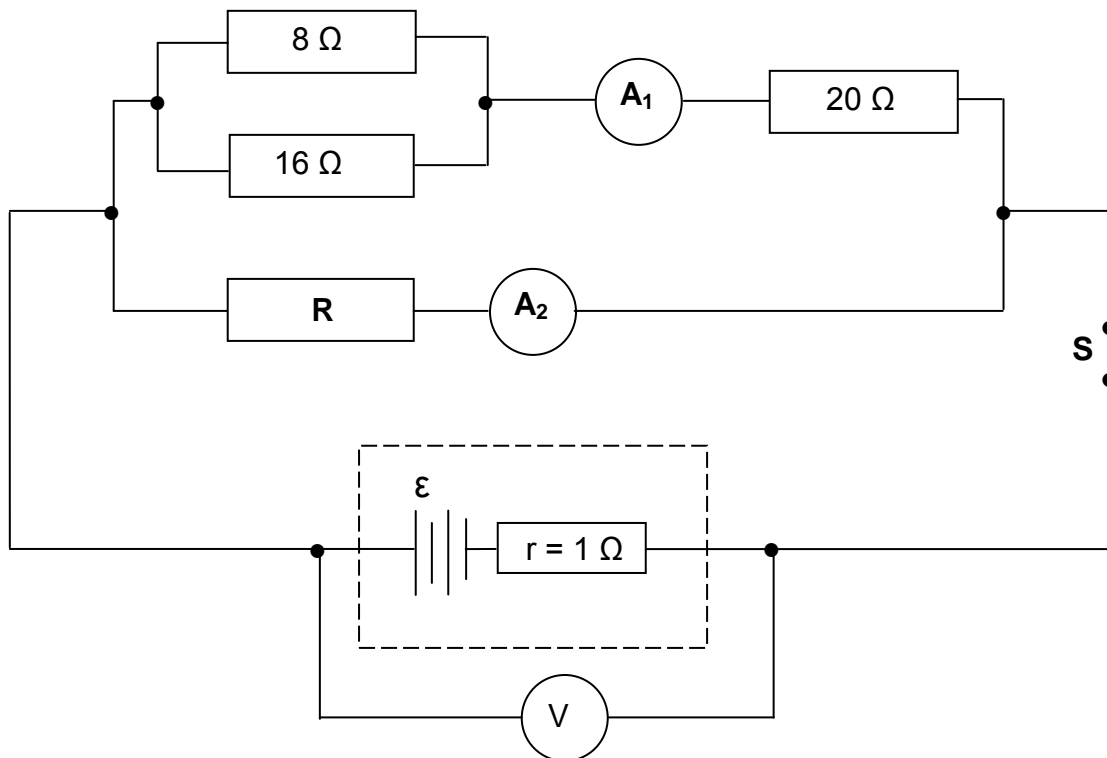

With switch **S** closed, the current passing through the $8\ \Omega$ resistor is $0,5\ \text{A}$.

- 9.1 State Ohm's law in words. (2)
 - 9.2 Calculate the reading on ammeter A_1 . (4)
 - 9.3 If device **R** delivers power of $12\ \text{W}$, calculate the reading on ammeter A_2 . (5)
 - 9.4 Calculate the reading on the voltmeter when switch **S** is open. (3)
- [14]**

QUESTION 10 (Start on a new page.)

10.1 A teacher demonstrates how current can be obtained using a bar magnet, a coil and a galvanometer. The teacher moves the bar magnet up and down, as shown by the arrow in the diagram below.

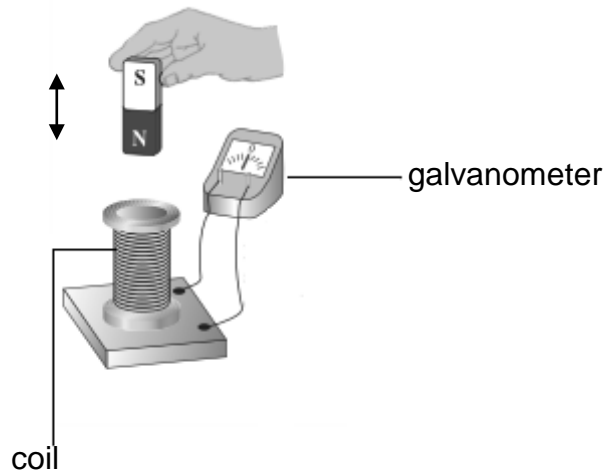

10.1.1 Briefly describe how the magnet must be moved in order to obtain a LARGE deflection on the galvanometer. (2)

The two devices, **A** and **B**, below operate on the principle described in QUESTION 10.1.1 above.

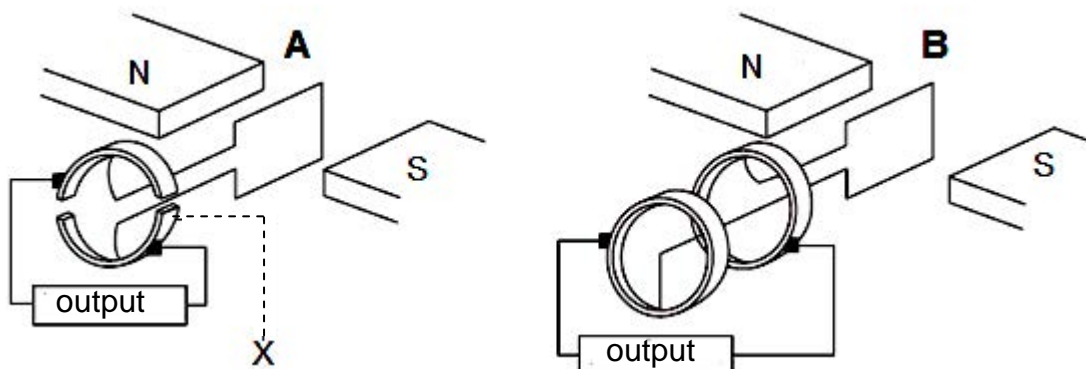

10.1.2 Write down the name of the principle. (1)

10.1.3 Write down the name of part **X** in device **A**. (1)

10.2 A 220 V, AC voltage is supplied from a wall socket to an electric kettle of resistance $40,33 \Omega$. Wall sockets provide rms voltages and currents.

Calculate the:

10.2.1 Electrical energy consumed by the kettle per second (4)

10.2.2 Maximum (peak) current through the kettle (3)

[11]

QUESTION 11 (Start on a new page.)

In an experiment to demonstrate the photoelectric effect, light of different wavelengths was shone onto a metal surface of a photoelectric cell. The maximum kinetic energy of the emitted electrons was determined for the various wavelengths and recorded in the table below.

INVERSE OF WAVELENGTH $\frac{1}{\lambda} (\times 10^6 \text{ m}^{-1})$	MAXIMUM KINETIC ENERGY $E_{k(\text{max})} (\times 10^{-19} \text{ J})$
5,00	6,60
3,30	3,30
2,50	1,70
2,00	0,70

- 11.1 What is meant by the term *photoelectric effect*? (2)
- 11.2 Draw a graph of $E_{k(\text{max})}$ (y-axis) versus $\frac{1}{\lambda}$ (x-axis) ON THE ATTACHED ANSWER SHEET. (3)
- 11.3 USE THE GRAPH to determine:
- 11.3.1 The threshold frequency of the metal in the photoelectric cell (4)
- 11.3.2 Planck's constant (4)

[13]

TOTAL: 150

**DATA FOR PHYSICAL SCIENCES GRADE 12
PAPER 1 (PHYSICS)**

**GEGEWENS VIR FISIESTE WETENSKAPPE GRAAD 12
VRAESTEL 1 (FISIKA)**

TABLE 1: PHYSICAL CONSTANTS/TABEL 1: FISIESTE KONSTANTES

NAME/NAAM	SYMBOL/SIMBOOL	VALUE/WAARDE
Acceleration due to gravity <i>Swaartekragversnelling</i>	g	9,8 m·s ⁻²
Universal gravitational constant <i>Universele gravitasiekonstante</i>	G	6,67 x 10 ⁻¹¹ N·m ² ·kg ⁻²
Radius of the Earth <i>Radius van die Aarde</i>	R _E	6,38 x 10 ⁶ m
Mass of the Earth <i>Massa van die Aarde</i>	M _E	5,98 x 10 ²⁴ kg
Speed of light in a vacuum <i>Spoed van lig in 'n vakuum</i>	c	3,0 x 10 ⁸ m·s ⁻¹
Planck's constant <i>Planck se konstante</i>	h	6,63 x 10 ⁻³⁴ J·s
Coulomb's constant <i>Coulomb se konstante</i>	k	9,0 x 10 ⁹ N·m ² ·C ⁻²
Charge on electron <i>Lading op elektron</i>	e	-1,6 x 10 ⁻¹⁹ C
Electron mass <i>Elektronmassa</i>	m _e	9,11 x 10 ⁻³¹ kg

TABLE 2: FORMULAE/TABEL 2: FORMULES

MOTION/BEWEGING

$v_f = v_i + a \Delta t$	$\Delta x = v_i \Delta t + \frac{1}{2} a \Delta t^2$ or/of $\Delta y = v_i \Delta t + \frac{1}{2} a \Delta t^2$
$v_f^2 = v_i^2 + 2a\Delta x$ or/of $v_f^2 = v_i^2 + 2a\Delta y$	$\Delta x = \left(\frac{v_i + v_f}{2} \right) \Delta t$ or/of $\Delta y = \left(\frac{v_i + v_f}{2} \right) \Delta t$

FORCE/KRAG

$F_{\text{net}} = ma$	$p = mv$
$f_s^{\text{max}} = \mu_s N$	$f_k = \mu_k N$
$F_{\text{net}} \Delta t = \Delta p$ $\Delta p = mv_f - mv_i$	$w = mg$
$F = G \frac{m_1 m_2}{d^2}$ or/of $F = G \frac{m_1 m_2}{r^2}$	$g = G \frac{M}{d^2}$ or/of $g = G \frac{M}{r^2}$

WORK, ENERGY AND POWER/ARBEID, ENERGIE EN DRYWING

$W = F \Delta x \cos \theta$	$U = mgh$ or/of $E_p = mgh$
$K = \frac{1}{2} mv^2$ or/of $E_k = \frac{1}{2} mv^2$	$W_{\text{net}} = \Delta K$ or/of $W_{\text{net}} = \Delta E_k$ $\Delta K = K_f - K_i$ or/of $\Delta E_k = E_{kf} - E_{ki}$
$W_{\text{nc}} = \Delta K + \Delta U$ or/of $W_{\text{nc}} = \Delta E_k + \Delta E_p$	$P = \frac{W}{\Delta t}$
$P_{\text{ave}} = Fv_{\text{ave}}$ / $P_{\text{gemid}} = Fv_{\text{gemid}}$	

WAVES, SOUND AND LIGHT/GOLWE, KLANK EN LIG

$v = f \lambda$	$T = \frac{1}{f}$
$f_L = \frac{v \pm v_L}{v \pm v_s} f_s$ $f_L = \frac{v \pm v_L}{v \pm v_b} f_b$	$E = hf$ or/of $E = \frac{hc}{\lambda}$
$E = W_o + E_{k(\text{max})}$ or/of $E = W_o + K_{\text{max}}$ where/waar	
$E = hf$ and/en $W_o = hf_0$ and/en $E_{k(\text{max})} = \frac{1}{2} mv_{\text{max}}^2$ or/of $K_{\text{max}} = \frac{1}{2} mv_{\text{max}}^2$	

ELECTROSTATICS/ELEKTROSTATIKA

$F = \frac{kQ_1Q_2}{r^2}$	$E = \frac{kQ}{r^2}$
$V = \frac{W}{q}$	$E = \frac{F}{q}$
$n = \frac{Q}{e}$ or/of $n = \frac{Q}{q_e}$	

ELECTRIC CIRCUITS/ELEKTRIESE STROOMBANE

$R = \frac{V}{I}$	emf (ϵ) = I(R + r) emk (ϵ) = I(R + r)
$R_s = R_1 + R_2 + \dots$ $\frac{1}{R_p} = \frac{1}{R_1} + \frac{1}{R_2} + \dots$	$q = I\Delta t$
$W = Vq$ $W = VI\Delta t$ $W = I^2R\Delta t$ $W = \frac{V^2\Delta t}{R}$	$P = \frac{W}{\Delta t}$ $P = VI$ $P = I^2R$ $P = \frac{V^2}{R}$

ALTERNATING CURRENT/WISSELSTROOM

$I_{rms} = \frac{I_{max}}{\sqrt{2}}$ / $I_{wgk} = \frac{I_{maks}}{\sqrt{2}}$	$P_{ave} = V_{rms}I_{rms}$ / $P_{gemiddeld} = V_{wgk}I_{wgk}$
$V_{rms} = \frac{V_{max}}{\sqrt{2}}$ / $V_{wgk} = \frac{V_{maks}}{\sqrt{2}}$	$P_{ave} = I_{rms}^2R$ / $P_{gemiddeld} = I_{wgk}^2R$
	$P_{ave} = \frac{V_{rms}^2}{R}$ / $P_{gemiddeld} = \frac{V_{wgk}^2}{R}$

CENTRE NUMBER:

--	--	--	--	--	--	--	--

EXAMINATION NUMBER:

--	--	--	--	--	--	--	--	--	--	--	--

ANSWER SHEET

QUESTION 11.2

Hand in this ANSWER SHEET with your ANSWER BOOK.

