



basic education

Department:
Basic Education
REPUBLIC OF SOUTH AFRICA

**NATIONAL
SENIOR CERTIFICATE**

GRADE 12

PHYSICAL SCIENCES: CHEMISTRY (P2)

FEBRUARY/MARCH 2015

MARKS: 150

TIME: 3 hours

This question paper consists of 17 pages and 4 data sheets.

INSTRUCTIONS AND INFORMATION

1. Write your examination number and centre number in the appropriate spaces on the ANSWER BOOK.
2. This question paper consists of TEN questions. Answer ALL the questions in the ANSWER BOOK.
3. Start EACH question on a NEW page in the ANSWER BOOK.
4. Number the answers correctly according to the numbering system used in this question paper.
5. Leave ONE line between two subquestions, for example between QUESTION 2.1 and QUESTION 2.2.
6. You may use a non-programmable calculator.
7. You may use appropriate mathematical instruments.
8. You are advised to use the attached DATA SHEETS.
9. Show ALL formulae and substitutions in ALL calculations.
10. Round off your final numerical answers to a minimum of TWO decimal places.
11. Give brief motivations, discussions, et cetera where required.
12. Write neatly and legibly.

QUESTION 1: MULTIPLE-CHOICE QUESTIONS

Four options are provided as possible answers to the following questions. Each question has only ONE correct answer. Write only the letter (A–D) next to the question number (1.1–1.10) in the ANSWER BOOK, for example 1.11. D.

1.1 Which ONE of the following compounds is an aldehyde?

- A Pentanal
- B Pentan-2-ol
- C Pentan-2-one
- D Ethyl propanoate (2)

1.2 Consider the reaction represented by the equation below:

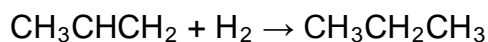

This reaction is an example of ...

- A hydration.
- B dehydration.
- C substitution.
- D hydrogenation. (2)

1.3 Which ONE of the following is a CORRECT description for a 0,1 mol·dm⁻³ hydrochloric acid solution?

- A Dilute strong acid
- B Dilute weak acid
- C Concentrated weak acid
- D Concentrated strong acid (2)

1.4 Eutrophication involves the following stages:

- (i) Increase in growth of algae
- (ii) Increase in nitrate concentration
- (iii) Death of fish
- (iv) Decrease in oxygen concentration

Which ONE of the following CORRECTLY represents the order in which these stages occur?

- A (i) (ii) (iii) (iv)
- B (i) (ii) (iv) (iii)
- C (ii) (i) (iii) (iv)
- D (ii) (i) (iv) (iii) (2)

1.5 Consider the reaction represented by the balanced equation below:

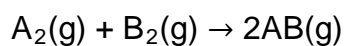

The activation energy for the forward reaction is 180 kJ and that for the reverse reaction is 200 kJ.

The heat of reaction (ΔH) is ...

- A + 20 kJ.
- B - 20 kJ.
- C + 380 kJ.
- D - 380 kJ. (2)

1.6 Consider the structural formula of a compound below.

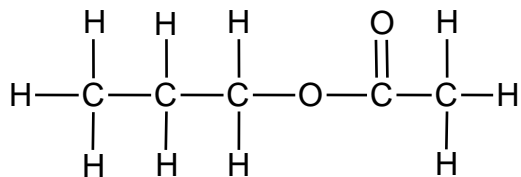

Which ONE of the following pairs of reactants can be used to prepare this compound in the laboratory?

- A Propanoic acid and ethanol
- B Propanoic acid and methanol
- C Ethanoic acid and propan-1-ol
- D Methanoic acid and propan-1-ol (2)

1.7 The reaction of an acid-base indicator, represented as $\text{HIn}(\text{aq})$, with $\text{H}_2\text{O}(\ell)$ reaches equilibrium according to the following balanced equation:

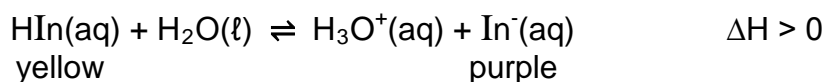

At equilibrium the colour of the solution is purple.

Which ONE of the following will change the colour of the solution from purple to yellow?

- A Add $\text{NaOH}(\text{aq})$
- B Add $\text{HCl}(\text{aq})$
- C Add water
- D Increase the temperature (2)

1.8 Which ONE of the following metals will NOT react spontaneously with sulphuric acid?

- A Zn
- B Mg
- C Cu
- D Fe

(2)

1.9 A learner wants to electroplate a copper ring with nickel. He uses the experimental set-up shown in the simplified diagram below.

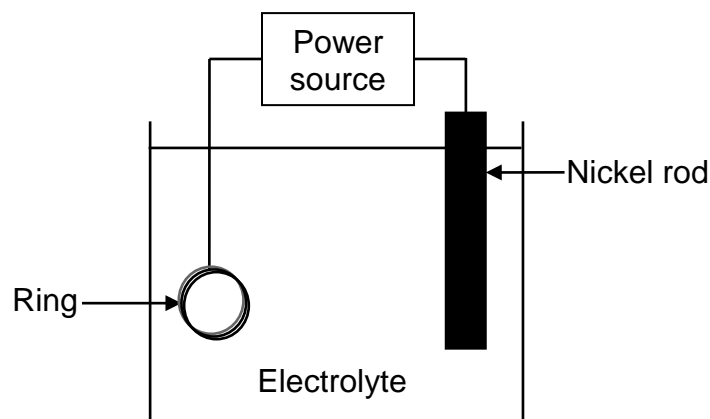

Which ONE of the following is CORRECT?

| | ANODE | CATHODE | ELECTROLYTE |
|---|--------------|----------------|--------------------|
| A | Copper ring | Nickel rod | CuSO_4 |
| B | Nickel rod | Copper ring | CuSO_4 |
| C | Copper ring | Nickel rod | NiSO_4 |
| D | Nickel rod | Copper ring | NiSO_4 |

(2)

1.10 Consider the equilibrium constants for the same reaction at two different temperatures below.

298 K: $K_c = 0,03$

318 K: $K_c = 0,005$

Which ONE of the following is CORRECT?

| | HEAT OF REACTION | YIELD OF PRODUCTS AS THE TEMPERATURE INCREASES |
|---|------------------|--|
| A | $\Delta H > 0$ | Increases |
| B | $\Delta H < 0$ | Decreases |
| C | $\Delta H > 0$ | Decreases |
| D | $\Delta H < 0$ | Remains the same |

(2)
[20]

QUESTION 2 (Start on a new page.)

The letters **A** to **F** in the table below represent six organic compounds.

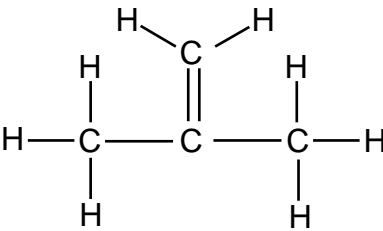
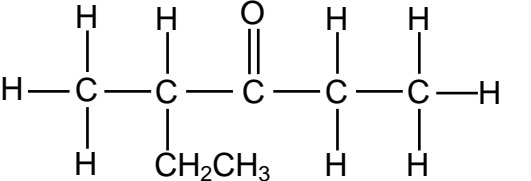
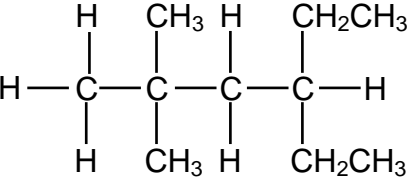
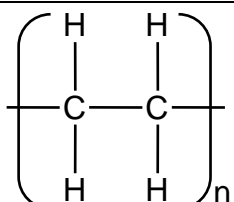
| | | | |
|----------|---|----------|---|
| A |  | B | 2-methylbutanoic acid |
| C |  | D |  |
| E | But-2-ene | F |  |

2.1 Write down the:

2.1.1 NAME of the functional group of compound **B** (1)

2.1.2 Homologous series to which compound **C** belongs (1)

2.1.3 Type of polymerisation reaction that produces compound **F** (1)

2.2 Write down the IUPAC name of:

2.2.1 The monomer used to prepare compound **F** (1)

2.2.2 Compound **C** (2)

2.2.3 Compound **D** (2)

2.3 Write down the NAME or FORMULA of each product formed during the complete combustion of compound **D**. (2)

2.4 Write down the structural formula of:

2.4.1 Compound **B** (2)

2.4.2 A CHAIN ISOMER of compound **A** (2)

- 2.5 A laboratory assistant uses bromine water to distinguish between compounds **D** and **E**. She adds bromine water to a sample of each in two different test tubes. She observes that the one compound decolourises the bromine water immediately, whilst the other one only reacts after placing the test tube in direct sunlight.

Write down the:

- 2.5.1 Letter (**D** or **E**) of the compound that will immediately decolourise the bromine water (1)
- 2.5.2 Name of the type of reaction that takes place in the test tube containing compound **D** (1)
- 2.5.3 Structural formula of the organic product formed in the test tube containing compound **E** (2)
- [18]**

QUESTION 3 (Start on a new page.)

Learners use compounds **A** to **C**, shown in the table below, to investigate a factor which influences the boiling point of organic compounds.

| | |
|----------|--|
| A | $\text{CH}_3\text{CH}_2\text{CH}_2\text{CH}_3$ |
| B | $\text{CH}_3\text{CH}_2\text{CH}_2\text{CH}_2\text{CH}_3$ |
| C | $\text{CH}_3\text{CH}_2\text{CH}_2\text{CH}_2\text{CH}_2\text{CH}_3$ |

- 3.1 Which ONE of the compounds (**A**, **B** or **C**) has the highest boiling point? (1)
- 3.2 For this investigation, write down the:
- 3.2.1 Independent variable (1)
- 3.2.2 Dependent variable (1)
- 3.3 Write down the name of the type of Van der Waals force that occurs between the molecules of compound **B**. (1)
- 3.4 How will the vapour pressure of 2-methylpentane compare to that of compound **C**? Write down only HIGHER THAN, LOWER THAN or EQUAL TO. (1)

The learners now compare the boiling points of compounds **D** and **E**, shown in the table below.

| | |
|----------|--|
| D | $\text{CH}_3\text{CH}_2\text{CH}_2\text{CH}_2\text{CH}_2\text{OH}$ |
| E | $\text{CH}_3\text{CH}_2\text{CH}_2\text{COOH}$ |

- 3.5 How does the boiling point of compound **D** compare to that of compound **E**? Write down HIGHER THAN, LOWER THAN or EQUAL TO. Fully explain the answer. (4)
- [9]**

QUESTION 4 (Start on a new page.)

In the flow diagram below, but-1-ene is used as starting material in the preparation of compound **A**.

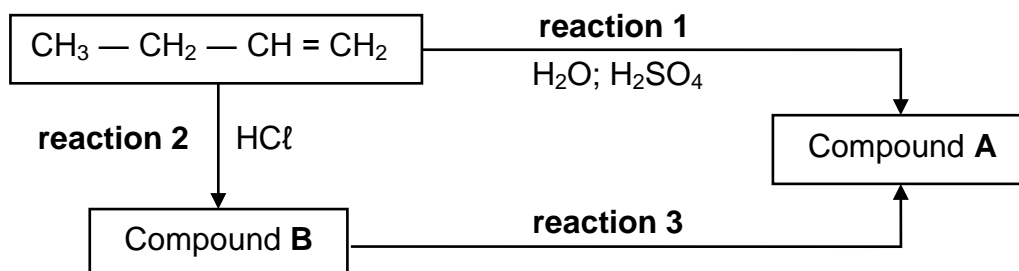

4.1 Is but-1-ene a SATURATED or UNSATURATED compound? Give a reason for the answer. (2)

4.2 Compound **A** is the major product formed in **reaction 1**.

Write down the:

4.2.1 Structural formula of compound **A** (2)

4.2.2 Type of reaction that takes place (1)

4.3 For compound **B**, write down the:

4.3.1 IUPAC name (2)

4.3.2 Structural formula of the positional isomer (2)

4.4 For **reaction 3**, write down:

4.4.1 TWO reaction conditions needed (2)

4.4.2 The type of reaction that occurs (1)

4.4.3 A balanced equation, using molecular formulae (3)

[15]

QUESTION 5 (Start on a new page.)

A group of learners uses the reaction of EXCESS hydrochloric acid (HCl) with zinc (Zn) to investigate factors which influence reaction rate. The balanced equation for the reaction is:

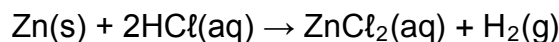

They use the same volume of hydrochloric acid and 1,2 g of zinc in each of five experiments. The reaction conditions and temperature readings before and after completion of the reaction in each experiment are summarised in the table below.

| Experiment | REACTION CONDITIONS | | | Time (s) | |
|------------|--|------------------|-------|----------|----|
| | Concentration of HCl (mol·dm ⁻³) | Temperature (°C) | | | |
| | | Before | After | | |
| 1 | 0,5 | 20 | 34 | granules | 50 |
| 2 | 0,5 | 20 | 35 | powder | 10 |
| 3 | 0,8 | 20 | 36 | powder | 6 |
| 4 | 0,5 | 35 | 50 | granules | 8 |
| 5 | 0,5 | 20 | 34 | granules | 11 |

5.1 Is the reaction between hydrochloric acid and zinc EXOTHERMIC or ENDOTHERMIC? Give a reason for the answer by referring to the data in the table. (2)

5.2 Give a reason for the difference in reaction rate observed for **Experiments 1** and **2**. (1)

5.3 The learners compare the results of **Experiments 1** and **3** to draw a conclusion regarding the effect of concentration on reaction rate. Give a reason why this is not a fair comparison. (1)

5.4 How does the rate of the reaction in **Experiment 5** compare to that in **Experiment 1**? Write down FASTER THAN, SLOWER THAN or EQUAL TO.

Write down the factor responsible for the difference in the rate of reaction and fully explain, by referring to the collision theory, how this factor affects reaction rate. (5)

5.5 Calculate the rate at which the hydrochloric acid reacts in **Experiment 4** in mol·s⁻¹. (6)
[15]

QUESTION 6 (Start on a new page.)

Pure hydrogen iodide, sealed in a 2 dm³ container at 721 K, decomposes according to the following balanced equation:

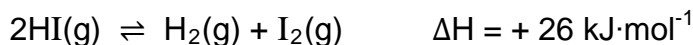

The graph below shows how reaction rate changes with time for this reversible reaction.

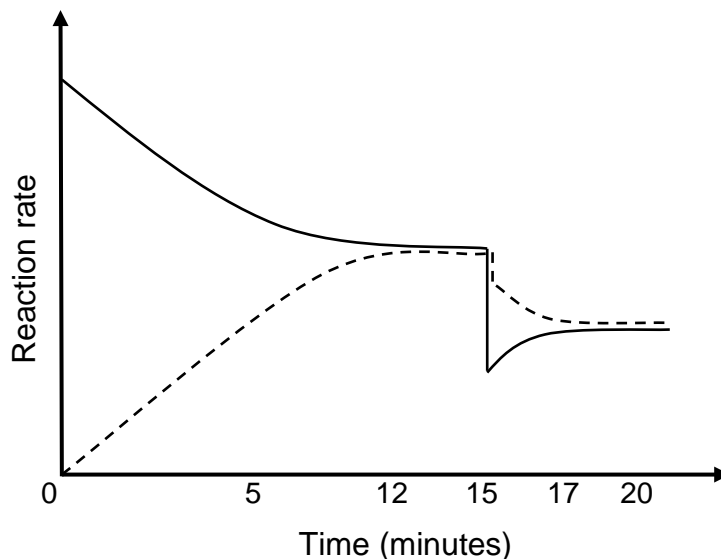

- 6.1 Write down the meaning of the term *reversible reaction*. (1)
- 6.2 How does the concentration of the reactant change between the 12th and the 15th minute? Write down only INCREASES, DECREASES or NO CHANGE. (1)
- 6.3 The rates of both the forward and the reverse reactions suddenly change at t = 15 minutes.
- 6.3.1 Give a reason for the sudden change in reaction rate. (1)
- 6.3.2 Fully explain how you arrived at the answer to QUESTION 6.3.1. (3)

The equilibrium constant (K_c) for the forward reaction is 0,02 at 721 K.

- 6.4 At equilibrium it is found that 0,04 mol HI(g) is present in the container. Calculate the concentration of H₂(g) at equilibrium. (6)
- 6.5 Calculate the equilibrium constant for the reverse reaction. (1)
- 6.6 The temperature is now increased to 800 K. How will the value of the equilibrium constant (K_c) for the forward reaction change? Write down only INCREASES, DECREASES or REMAINS THE SAME. (1)

[14]

QUESTION 7 (Start on a new page.)

7.1 Sulphuric acid is a diprotic acid.

7.1.1 Define an *acid* in terms of the Lowry-Brønsted theory. (2)

7.1.2 Give a reason why sulphuric acid is referred to as a *diprotic acid*. (1)

7.2 The hydrogen carbonate ion can act as both an acid and a base. It reacts with water according to the following balanced equation:

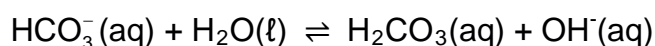

7.2.1 Write down ONE word for the underlined phrase. (1)

7.2.2 $\text{HCO}_3^-(\text{aq})$ acts as base in the above reaction. Write down the formula of the conjugate acid of $\text{HCO}_3^-(\text{aq})$. (1)

7.3 A learner accidentally spills some sulphuric acid of concentration $6 \text{ mol}\cdot\text{dm}^{-3}$ from a flask on the laboratory bench. Her teacher tells her to neutralise the spilled acid by sprinkling sodium hydrogen carbonate powder onto it. The reaction that takes place is: (Assume that the H_2SO_4 ionises completely.)



The fizzing, due to the formation of carbon dioxide, stops after the learner has added 27 g sodium hydrogen carbonate to the spilled acid.

7.3.1 Calculate the volume of sulphuric acid that spilled. Assume that all the sodium hydrogen carbonate reacts with all the acid. (6)

The learner now dilutes some of the $6 \text{ mol}\cdot\text{dm}^{-3}$ sulphuric acid solution in the flask to $0,1 \text{ mol}\cdot\text{dm}^{-3}$.

7.3.2 Calculate the volume of the $6 \text{ mol}\cdot\text{dm}^{-3}$ sulphuric acid solution needed to prepare 1 dm^3 of the dilute acid. (2)

During a titration 25 cm^3 of the $0,1 \text{ mol}\cdot\text{dm}^{-3}$ sulphuric acid solution is added to an Erlenmeyer flask and titrated with a $0,1 \text{ mol}\cdot\text{dm}^{-3}$ sodium hydroxide solution.

7.3.3 The learner uses bromothymol blue as indicator. What is the purpose of this indicator? (1)

7.3.4 Calculate the pH of the solution in the flask after the addition of 30 cm^3 of sodium hydroxide. The endpoint of the titration is not yet reached at this point. (8)

[22]

QUESTION 8 (Start on a new page.)

A learner conducts two experiments to investigate the reaction between copper (Cu) and a silver nitrate solution, $\text{AgNO}_3(\text{aq})$.

EXPERIMENT 1

The learner adds a small amount of copper (Cu) powder to a test tube containing silver nitrate solution, $\text{AgNO}_3(\text{aq})$. The solution changes from colourless to blue after a while.

Before addition of Cu(s)

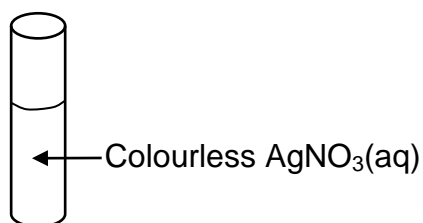

After addition of Cu(s)

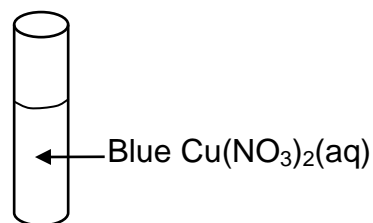

8.1 Define the term *oxidising agent*. (2)

8.2 Explain why the solution turns blue by referring to the relative strength of oxidising agents. (4)

EXPERIMENT 2

The learner now sets up a galvanic cell as shown below. The cell functions under standard conditions.

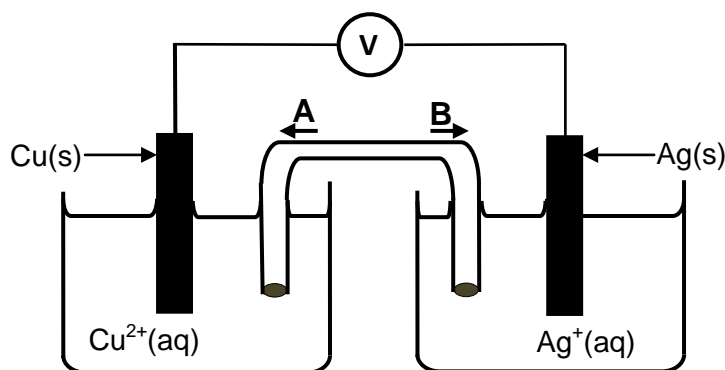

8.3 Write down the energy conversion that takes place in this cell. (1)

8.4 In which direction (**A** or **B**) will ANIONS move in the salt bridge? (1)

8.5 Calculate the emf of the above cell under standard conditions. (4)

8.6 Write down the balanced equation for the net cell reaction that takes place in this cell. (3)

8.7 How will the addition of 100 cm^3 of a $1 \text{ mol} \cdot \text{dm}^{-3}$ silver nitrate solution to the silver half-cell influence the initial emf of this cell? Write down only INCREASES, DECREASES or REMAINS THE SAME. (1)

[16]

QUESTION 9 (Start on a new page.)

The apparatus below is used to demonstrate the electrolysis of a concentrated sodium chloride solution. Both electrodes are made of carbon. A few drops of universal indicator are added to the electrolyte. The equation for the net cell reaction is:

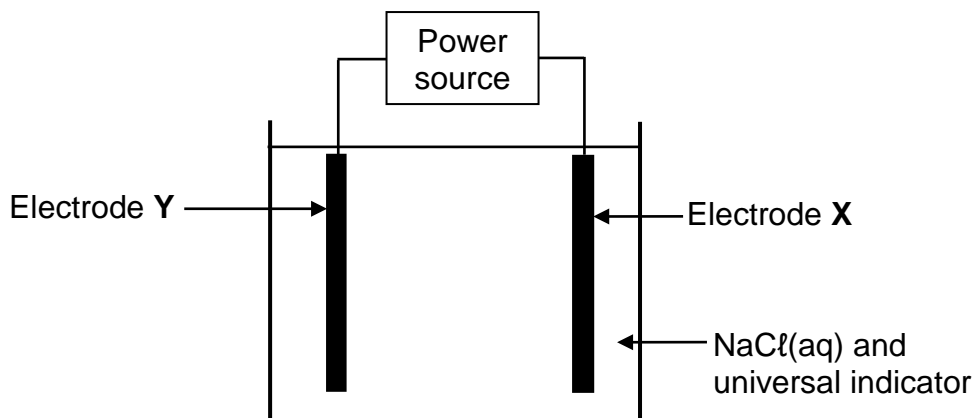
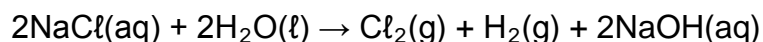

Initially the solution has a green colour. Universal indicator becomes red in acidic solutions and purple in alkaline solutions.

9.1 Define the term *electrolyte*. (2)

When the power source is switched on, the colour of the electrolyte around electrode Y changes from green to purple.

9.2 Write down the:

9.2.1 Half-reaction that takes place at electrode Y (2)

9.2.2 NAME or FORMULA of the gas released at electrode X (1)

9.3 Refer to the Table of Standard Reduction Potentials to explain why hydrogen gas, and not sodium, is formed at the cathode of this cell. (2)
[7]

QUESTION 10 (Start on a new page.)

Reactions **A**, **B**, **C** and **D** in the flow diagram below represent the manufacturing of Fertiliser **X**.

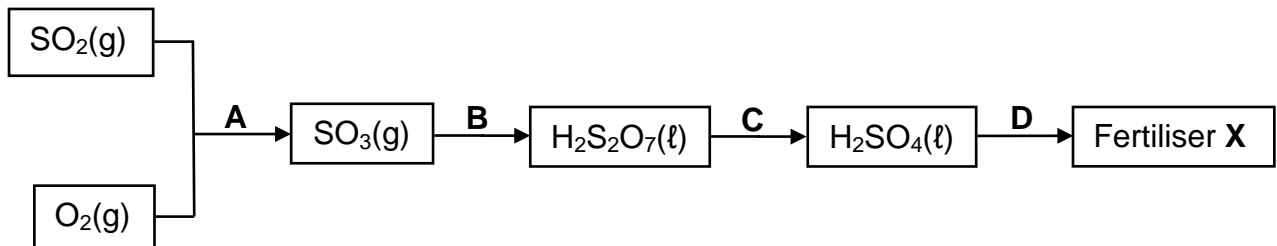

10.1 Write down the name of the industrial preparation of sulphuric acid. (1)

10.2 Write down the:

10.2.1 NAME or FORMULA of the catalyst used in reaction **A** (1)

10.2.2 Balanced equation for reaction **C** (3)

10.3 Ammonia is one of the reactants used in reaction **D** to make Fertiliser **X**.

Write down:

10.3.1 A balanced equation for reaction **D** (3)

10.3.2 The NAME of Fertiliser **X** (1)

10.4 Two 50 kg bags, containing fertilisers **P** and **Q** respectively, are labelled as follows:

Fertiliser **P**: 5 : 2 : 3 (25)

Fertiliser **Q**: 1 : 3 : 4 (20)

10.4.1 What do the numbers (25) and (20) on the labels represent? (1)

10.4.2 Using calculations, determine which fertiliser (**P** or **Q**) contains the greater mass of potassium. (4)

[14]

TOTAL: 150

**DATA FOR PHYSICAL SCIENCES GRADE 12
PAPER 2 (CHEMISTRY)**

**GEGEWENS VIR FISIESTE WETENSKAPPE GRAAD 12
VRAESTEL 2 (CHEMIE)**

TABLE 1: PHYSICAL CONSTANTS/TABEL 1: FISIESTE KONSTANTES

| NAME/NAAM | SYMBOL/SIMBOOL | VALUE/WAARDE |
|---|----------------|---|
| Standard pressure <i>Standaarddruk</i> | p^θ | $1,013 \times 10^5 \text{ Pa}$ |
| Molar gas volume at STP <i>Molêre gasvolume by STD</i> | V_m | $22,4 \text{ dm}^3 \cdot \text{mol}^{-1}$ |
| Standard temperature <i>Standaardtemperatuur</i> | T^θ | 273 K |
| Charge on electron <i>Lading op elektron</i> | e | $-1,6 \times 10^{-19} \text{ C}$ |
| Avogadro's constant <i>Avogadro-konstante</i> | N_A | $6,02 \times 10^{23} \text{ mol}^{-1}$ |

TABLE 2: FORMULAE/TABEL 2: FORMULES

| | |
|--|---|
| $n = \frac{m}{M}$ | $n = \frac{N}{N_A}$ |
| $c = \frac{n}{V}$ or/of $c = \frac{m}{MV}$ | $n = \frac{V}{V_m}$ |
| $\frac{c_a v_a}{c_b v_b} = \frac{n_a}{n_b}$ | $\text{pH} = -\log[\text{H}_3\text{O}^+]$ |
| $K_w = [\text{H}_3\text{O}^+][\text{OH}^-] = 1 \times 10^{-14}$ at/by 298 K | |
| $E_{\text{cell}}^\theta = E_{\text{cathode}}^\theta - E_{\text{anode}}^\theta / E_{\text{sel}}^\theta = E_{\text{katode}}^\theta - E_{\text{anode}}^\theta$ | |
| or/of $E_{\text{cell}}^\theta = E_{\text{reduction}}^\theta - E_{\text{oxidation}}^\theta / E_{\text{sel}}^\theta = E_{\text{reduksie}}^\theta - E_{\text{oksidasie}}^\theta$ | |
| or/of $E_{\text{cell}}^\theta = E_{\text{oxidising agent}}^\theta - E_{\text{reducing agent}}^\theta / E_{\text{sel}}^\theta = E_{\text{oksideermiddel}}^\theta - E_{\text{reduseermiddel}}^\theta$ | |

TABLE 4A: STANDARD REDUCTION POTENTIALS
TABEL 4A: STANDAARD-REDUKSIEPOTENSIALE

| Half-reactions/ <i>Halfreaksies</i> | E^{\ominus} (V) |
|---|-------------------|
| $F_2(g) + 2e^- \rightleftharpoons 2F^-$ | + 2,87 |
| $Co^{3+} + e^- \rightleftharpoons Co^{2+}$ | + 1,81 |
| $H_2O_2 + 2H^+ + 2e^- \rightleftharpoons 2H_2O$ | +1,77 |
| $MnO_4^- + 8H^+ + 5e^- \rightleftharpoons Mn^{2+} + 4H_2O$ | + 1,51 |
| $Cl_2(g) + 2e^- \rightleftharpoons 2Cl^-$ | + 1,36 |
| $Cr_2O_7^{2-} + 14H^+ + 6e^- \rightleftharpoons 2Cr^{3+} + 7H_2O$ | + 1,33 |
| $O_2(g) + 4H^+ + 4e^- \rightleftharpoons 2H_2O$ | + 1,23 |
| $MnO_2 + 4H^+ + 2e^- \rightleftharpoons Mn^{2+} + 2H_2O$ | + 1,23 |
| $Pt^{2+} + 2e^- \rightleftharpoons Pt$ | + 1,20 |
| $Br_2(l) + 2e^- \rightleftharpoons 2Br^-$ | + 1,07 |
| $NO_3^- + 4H^+ + 3e^- \rightleftharpoons NO(g) + 2H_2O$ | + 0,96 |
| $Hg^{2+} + 2e^- \rightleftharpoons Hg(l)$ | + 0,85 |
| $Ag^+ + e^- \rightleftharpoons Ag$ | + 0,80 |
| $NO_3^- + 2H^+ + e^- \rightleftharpoons NO_2(g) + H_2O$ | + 0,80 |
| $Fe^{3+} + e^- \rightleftharpoons Fe^{2+}$ | + 0,77 |
| $O_2(g) + 2H^+ + 2e^- \rightleftharpoons H_2O_2$ | + 0,68 |
| $I_2 + 2e^- \rightleftharpoons 2I^-$ | + 0,54 |
| $Cu^+ + e^- \rightleftharpoons Cu$ | + 0,52 |
| $SO_2 + 4H^+ + 4e^- \rightleftharpoons S + 2H_2O$ | + 0,45 |
| $2H_2O + O_2 + 4e^- \rightleftharpoons 4OH^-$ | + 0,40 |
| $Cu^{2+} + 2e^- \rightleftharpoons Cu$ | + 0,34 |
| $SO_4^{2-} + 4H^+ + 2e^- \rightleftharpoons SO_2(g) + 2H_2O$ | + 0,17 |
| $Cu^{2+} + e^- \rightleftharpoons Cu^+$ | + 0,16 |
| $Sn^{4+} + 2e^- \rightleftharpoons Sn^{2+}$ | + 0,15 |
| $S + 2H^+ + 2e^- \rightleftharpoons H_2S(g)$ | + 0,14 |
| $2H^+ + 2e^- \rightleftharpoons H_2(g)$ | 0,00 |
| $Fe^{3+} + 3e^- \rightleftharpoons Fe$ | - 0,06 |
| $Pb^{2+} + 2e^- \rightleftharpoons Pb$ | - 0,13 |
| $Sn^{2+} + 2e^- \rightleftharpoons Sn$ | - 0,14 |
| $Ni^{2+} + 2e^- \rightleftharpoons Ni$ | - 0,27 |
| $Co^{2+} + 2e^- \rightleftharpoons Co$ | - 0,28 |
| $Cd^{2+} + 2e^- \rightleftharpoons Cd$ | - 0,40 |
| $Cr^{3+} + e^- \rightleftharpoons Cr^{2+}$ | - 0,41 |
| $Fe^{2+} + 2e^- \rightleftharpoons Fe$ | - 0,44 |
| $Cr^{3+} + 3e^- \rightleftharpoons Cr$ | - 0,74 |
| $Zn^{2+} + 2e^- \rightleftharpoons Zn$ | - 0,76 |
| $2H_2O + 2e^- \rightleftharpoons H_2(g) + 2OH^-$ | - 0,83 |
| $Cr^{2+} + 2e^- \rightleftharpoons Cr$ | - 0,91 |
| $Mn^{2+} + 2e^- \rightleftharpoons Mn$ | - 1,18 |
| $Al^{3+} + 3e^- \rightleftharpoons Al$ | - 1,66 |
| $Mg^{2+} + 2e^- \rightleftharpoons Mg$ | - 2,36 |
| $Na^+ + e^- \rightleftharpoons Na$ | - 2,71 |
| $Ca^{2+} + 2e^- \rightleftharpoons Ca$ | - 2,87 |
| $Sr^{2+} + 2e^- \rightleftharpoons Sr$ | - 2,89 |
| $Ba^{2+} + 2e^- \rightleftharpoons Ba$ | - 2,90 |
| $Cs^+ + e^- \rightleftharpoons Cs$ | - 2,92 |
| $K^+ + e^- \rightleftharpoons K$ | - 2,93 |
| $Li^+ + e^- \rightleftharpoons Li$ | - 3,05 |

Increasing oxidising ability/*Toenemende oksiderende vermoë*

Increasing reducing ability/*Toenemende reduserende vermoë*

TABLE 4B: STANDARD REDUCTION POTENTIALS
TABEL 4B: STANDAARD-REDUKSIEPOTENSIALE

Increasing oxidising ability/Toenemende oksiderende vermoë

| Half-reactions/ <i>Halfreaksies</i> | E^{\ominus} (V) |
|---|-------------------|
| $\text{Li}^+ + e^- \rightleftharpoons \text{Li}$ | -3,05 |
| $\text{K}^+ + e^- \rightleftharpoons \text{K}$ | -2,93 |
| $\text{Cs}^+ + e^- \rightleftharpoons \text{Cs}$ | -2,92 |
| $\text{Ba}^{2+} + 2e^- \rightleftharpoons \text{Ba}$ | -2,90 |
| $\text{Sr}^{2+} + 2e^- \rightleftharpoons \text{Sr}$ | -2,89 |
| $\text{Ca}^{2+} + 2e^- \rightleftharpoons \text{Ca}$ | -2,87 |
| $\text{Na}^+ + e^- \rightleftharpoons \text{Na}$ | -2,71 |
| $\text{Mg}^{2+} + 2e^- \rightleftharpoons \text{Mg}$ | -2,36 |
| $\text{Al}^{3+} + 3e^- \rightleftharpoons \text{Al}$ | -1,66 |
| $\text{Mn}^{2+} + 2e^- \rightleftharpoons \text{Mn}$ | -1,18 |
| $\text{Cr}^{2+} + 2e^- \rightleftharpoons \text{Cr}$ | -0,91 |
| $2\text{H}_2\text{O} + 2e^- \rightleftharpoons \text{H}_2(\text{g}) + 2\text{OH}^-$ | -0,83 |
| $\text{Zn}^{2+} + 2e^- \rightleftharpoons \text{Zn}$ | -0,76 |
| $\text{Cr}^{3+} + 3e^- \rightleftharpoons \text{Cr}$ | -0,74 |
| $\text{Fe}^{2+} + 2e^- \rightleftharpoons \text{Fe}$ | -0,44 |
| $\text{Cr}^{3+} + e^- \rightleftharpoons \text{Cr}^{2+}$ | -0,41 |
| $\text{Cd}^{2+} + 2e^- \rightleftharpoons \text{Cd}$ | -0,40 |
| $\text{Co}^{2+} + 2e^- \rightleftharpoons \text{Co}$ | -0,28 |
| $\text{Ni}^{2+} + 2e^- \rightleftharpoons \text{Ni}$ | -0,27 |
| $\text{Sn}^{2+} + 2e^- \rightleftharpoons \text{Sn}$ | -0,14 |
| $\text{Pb}^{2+} + 2e^- \rightleftharpoons \text{Pb}$ | -0,13 |
| $\text{Fe}^{3+} + 3e^- \rightleftharpoons \text{Fe}$ | -0,06 |
| $2\text{H}^+ + 2e^- \rightleftharpoons \text{H}_2(\text{g})$ | 0,00 |
| $\text{S} + 2\text{H}^+ + 2e^- \rightleftharpoons \text{H}_2\text{S}(\text{g})$ | +0,14 |
| $\text{Sn}^{4+} + 2e^- \rightleftharpoons \text{Sn}^{2+}$ | +0,15 |
| $\text{Cu}^{2+} + e^- \rightleftharpoons \text{Cu}^+$ | +0,16 |
| $\text{SO}_4^{2-} + 4\text{H}^+ + 2e^- \rightleftharpoons \text{SO}_2(\text{g}) + 2\text{H}_2\text{O}$ | +0,17 |
| $\text{Cu}^{2+} + 2e^- \rightleftharpoons \text{Cu}$ | +0,34 |
| $2\text{H}_2\text{O} + \text{O}_2 + 4e^- \rightleftharpoons 4\text{OH}^-$ | +0,40 |
| $\text{SO}_2 + 4\text{H}^+ + 4e^- \rightleftharpoons \text{S} + 2\text{H}_2\text{O}$ | +0,45 |
| $\text{Cu}^+ + e^- \rightleftharpoons \text{Cu}$ | +0,52 |
| $\text{I}_2 + 2e^- \rightleftharpoons 2\text{I}^-$ | +0,54 |
| $\text{O}_2(\text{g}) + 2\text{H}^+ + 2e^- \rightleftharpoons \text{H}_2\text{O}_2$ | +0,68 |
| $\text{Fe}^{3+} + e^- \rightleftharpoons \text{Fe}^{2+}$ | +0,77 |
| $\text{NO}_3^- + 2\text{H}^+ + e^- \rightleftharpoons \text{NO}_2(\text{g}) + \text{H}_2\text{O}$ | +0,80 |
| $\text{Ag}^+ + e^- \rightleftharpoons \text{Ag}$ | +0,80 |
| $\text{Hg}^{2+} + 2e^- \rightleftharpoons \text{Hg}(\ell)$ | +0,85 |
| $\text{NO}_3^- + 4\text{H}^+ + 3e^- \rightleftharpoons \text{NO}(\text{g}) + 2\text{H}_2\text{O}$ | +0,96 |
| $\text{Br}_2(\ell) + 2e^- \rightleftharpoons 2\text{Br}^-$ | +1,07 |
| $\text{Pt}^{2+} + 2e^- \rightleftharpoons \text{Pt}$ | +1,20 |
| $\text{MnO}_2 + 4\text{H}^+ + 2e^- \rightleftharpoons \text{Mn}^{2+} + 2\text{H}_2\text{O}$ | +1,23 |
| $\text{O}_2(\text{g}) + 4\text{H}^+ + 4e^- \rightleftharpoons 2\text{H}_2\text{O}$ | +1,23 |
| $\text{Cr}_2\text{O}_7^{2-} + 14\text{H}^+ + 6e^- \rightleftharpoons 2\text{Cr}^{3+} + 7\text{H}_2\text{O}$ | +1,33 |
| $\text{Cl}_2(\text{g}) + 2e^- \rightleftharpoons 2\text{Cl}^-$ | +1,36 |
| $\text{MnO}_4^- + 8\text{H}^+ + 5e^- \rightleftharpoons \text{Mn}^{2+} + 4\text{H}_2\text{O}$ | +1,51 |
| $\text{H}_2\text{O}_2 + 2\text{H}^+ + 2e^- \rightleftharpoons 2\text{H}_2\text{O}$ | +1,77 |
| $\text{Co}^{3+} + e^- \rightleftharpoons \text{Co}^{2+}$ | +1,81 |
| $\text{F}_2(\text{g}) + 2e^- \rightleftharpoons 2\text{F}^-$ | +2,87 |

Increasing reducing ability/Toenemende reduserende vermoë