



**Mathematics
Paper 2
FORM 4
2018**

TIME: 3 hours

TOTAL: 150 marks

EXAMINER: Mrs D Algie

**Moderators: Mrs A Gunning
Ms M Eastes**

NAME:

TEACHER:

**PLEASE READ THE FOLLOWING INSTRUCTIONS CAREFULLY BEFORE
ANSWERING THE QUESTIONS.**

- This question paper consists of 12 questions and 21 pages. An information sheet is also attached. Please check that your question paper is complete.
- Read and answer all questions carefully.
- It is in your own interest to write legibly and to present your work neatly.
- All necessary working which you have used in determining your answers **must** be clearly shown.
- Approved non-programmable calculators may be used, except where otherwise stated. Where necessary give answers correct to **1 decimal place** unless otherwise stated.
- Ensure that your calculator is in DEGREE mode.
- Please note, diagrams are not necessarily drawn to scale.

1.	2.	3.	4.	5.	6.	7.
18	21	9	6	14	6	9
8.	9.	10.	11.	12	TOTAL:	%
14	15	14	8	16	150	

SECTION A:

QUESTION 1:

A(- 1; 1), B(5; 3) and C(7; - 5) are three points in the Cartesian plane.

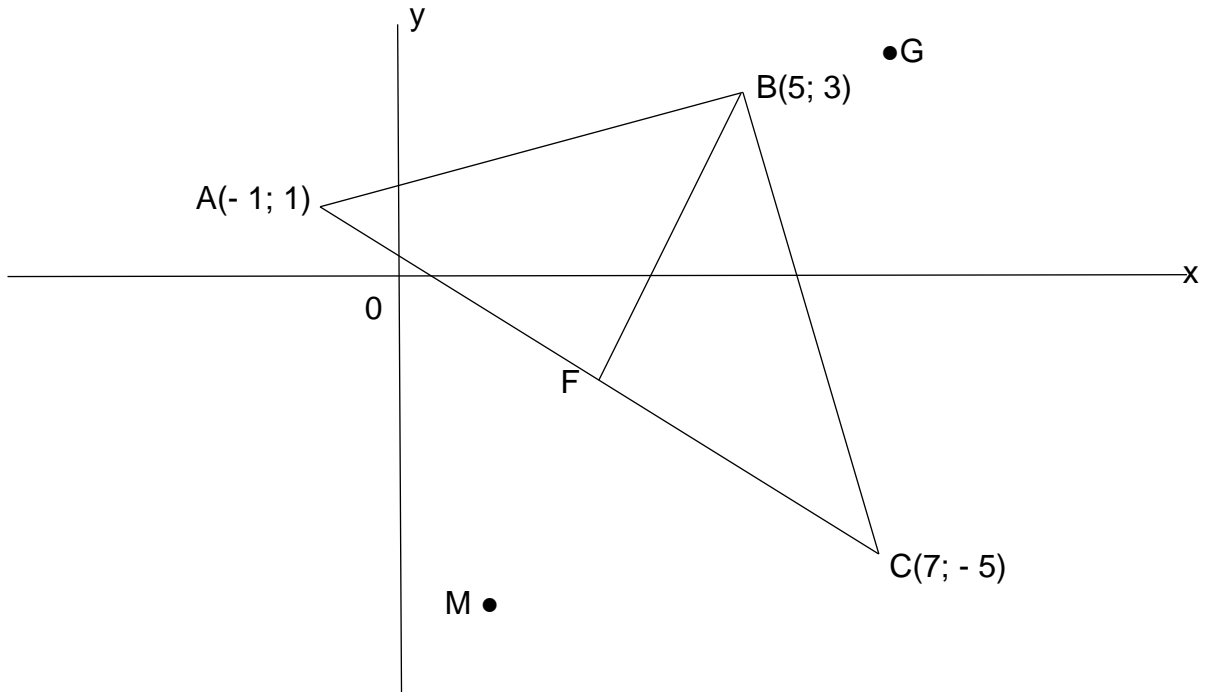

a) Given that $AF = FC$ find the co-ordinates of F. (2)

b) Determine the equation of BF. (4)

c) Calculate the co-ordinates of D if ABCD is a parallelogram. (3)

d) If G is the point (6; y), join FG and calculate the value of y if $\widehat{AFG} = 90^\circ$ (5)

e) If F has co-ordinates (3; - 2) and M is the point (x; - 6) determine the value of x if **B, F and M are collinear.** (4)

[18]

QUESTION 2:

a) Simplify the following:

$$\frac{\sin(90^\circ - \alpha) \cdot \tan(180^\circ - \alpha) \cdot \cos(180^\circ + \alpha)}{\cos(-\alpha) \cdot \sin(720^\circ + \alpha)} \quad (6)$$

b) Given: $3 \cos A + 2 = 0$ and $\tan A > 0$ calculate by means of a sketch,
[WITHOUT A CALCULATOR] the value of: $\tan A$. (5)

c) Prove the following identity:

$$\frac{1 + \sin x - \cos^2 x}{\cos x \sin x + \cos x} = \tan x \quad (5)$$

d) Given the equation, $\tan(x - 10^\circ) = -0,718$ solve for $x \in [-270^\circ; 180^\circ]$ (5)

[21]

QUESTION 3:

Sketched below are the graphs of $f(x) = \sin ax$ and $g(x) = \cos(x - b)$

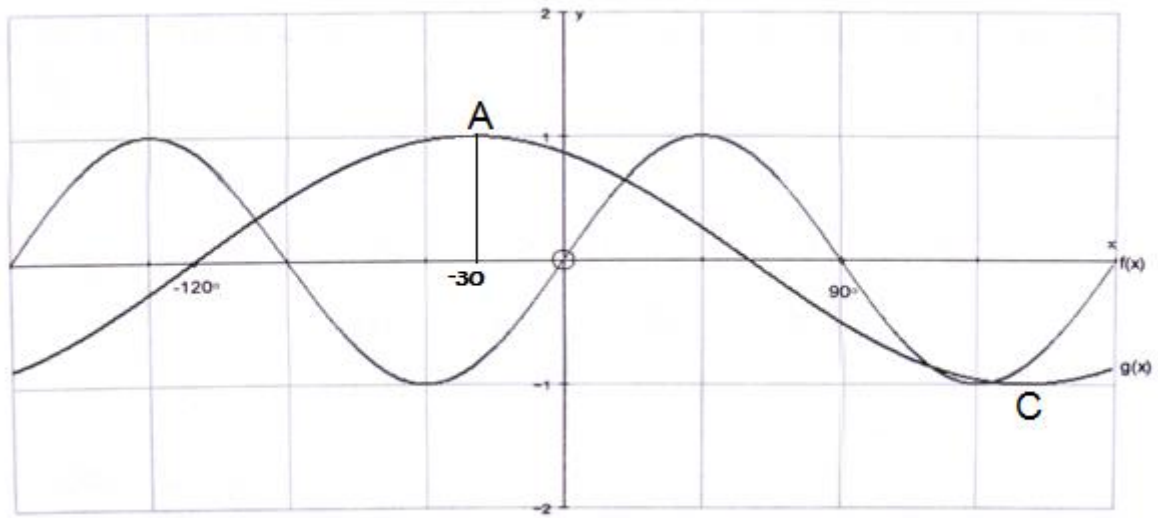

- a) Determine the values of a and b . (2)

- b) Determine the co-ordinates of C , a turning point on $g(x)$. (2)

- c) For which value(s) of x , is $f(x) \cdot g(x) \geq 0$? (3)

- d) Determine the equation of a new graph $h(x)$, if $f(x)$ is shifted 45° to the left and reflected in the x-axis. (2)

[9]

QUESTION 4: [Volume of a cone = $\frac{1}{3}\pi r^2 H$: Volume of a sphere = $\frac{4}{3}\pi r^3$]

Calculate the volume of the shape below.

[6]

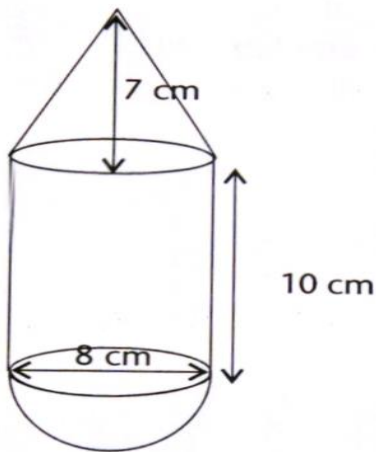

QUESTION 5:

The approximate electricity charges in Rands of 27 flats in a block in Ballito, in a given month, were recorded as follows.

580	600	640	680	690	690	690	700	700
700	750	750	760	770	780	800	800	810
810	810	830	870	880	900	910	950	970

a) Complete the table:

Cost in Rands	Frequency	Cumulative Frequency
$500 \leq x < 600$		
$600 \leq x < 700$		
$700 \leq x < 800$		
$800 \leq x < 900$		
$900 \leq x < 1000$		
TOTAL:		

(2)

b) Draw an ogive on the given set of axes below.

(4)

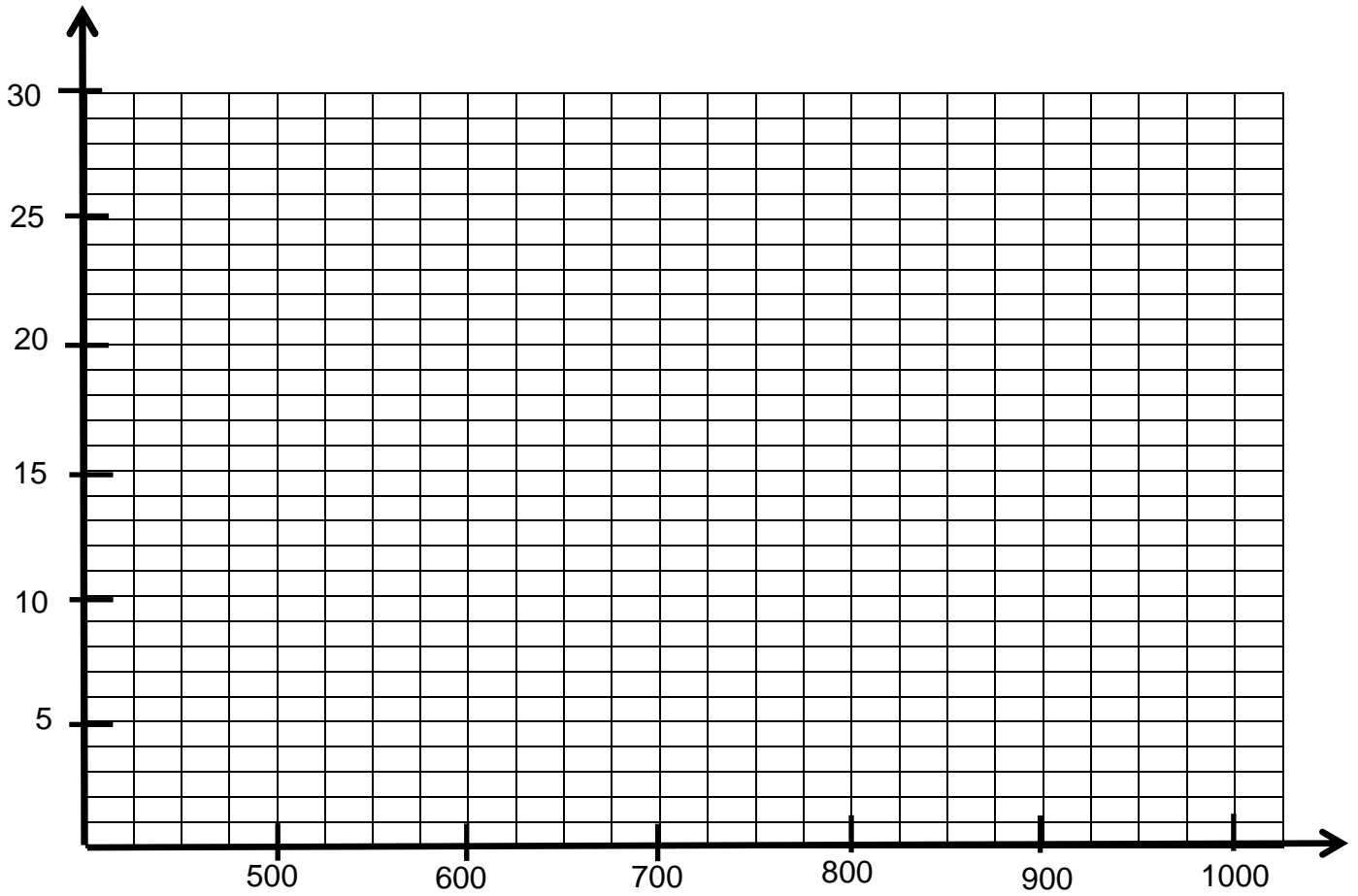

c) Use your graph to approximate: [Show where you read your answer]

1) the median (2)

2) the Interquartile Range. (5)

[13]

QUESTION 6: [Give reasons with all statements]

O is the centre of the circle. $MQ = 30\text{cm}$ and $ON \perp MQ$. If $TN = x$ and $OT = 2x$

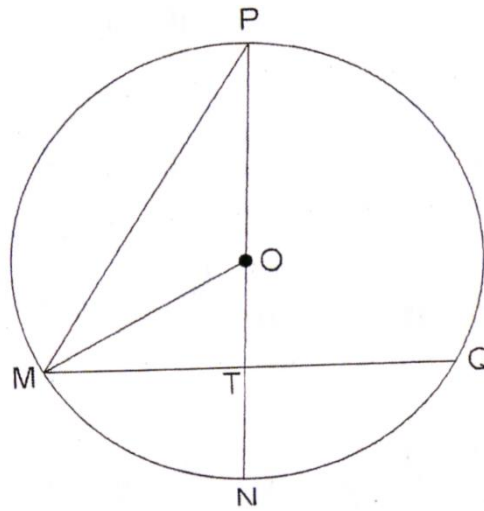

Determine:

- a) the length of OM in terms of x . (2)

- b) the value of x , leaving answer in simplest surd form. (4)

[6]

QUESTION 7: [Give reasons with all statements]

ABC is a tangent to the circle at B. $DE \parallel BG$. $\widehat{GBC} = 15^\circ$ and $\widehat{EDG} = 80^\circ$.
 Calculate the sizes of the following angles. E

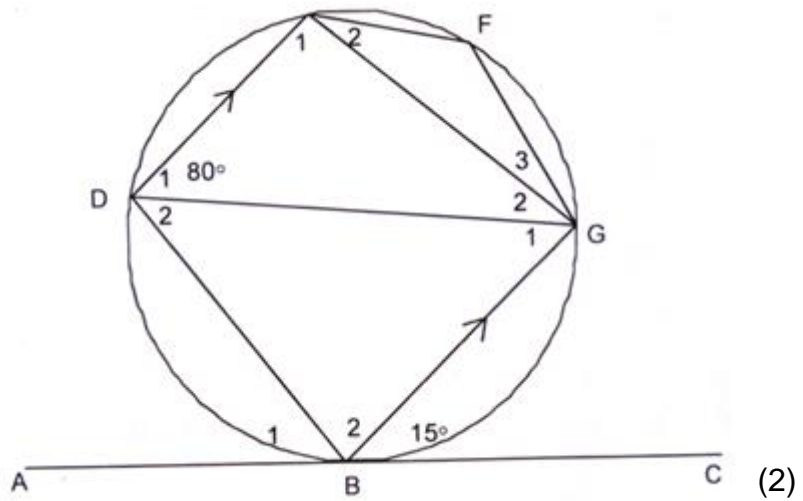

a) \widehat{F} (2)

b) \widehat{B}_1 (3)

c) \widehat{E}_1 (3)

d) \widehat{G}_2 (1)

[9]

SECTION B:

QUESTION 8:

- a) Give the general solution of: $3\sin^2 \theta - 2\sin \theta - 1 = 0$ (5)

b) The diagram LNPM below, represents a section of a construction crane.

$LN = 19\text{m}$, $PM = 87\text{m}$ $\widehat{LPN} = 62,3^\circ$ and $\widehat{PLM} = 64,6^\circ$.

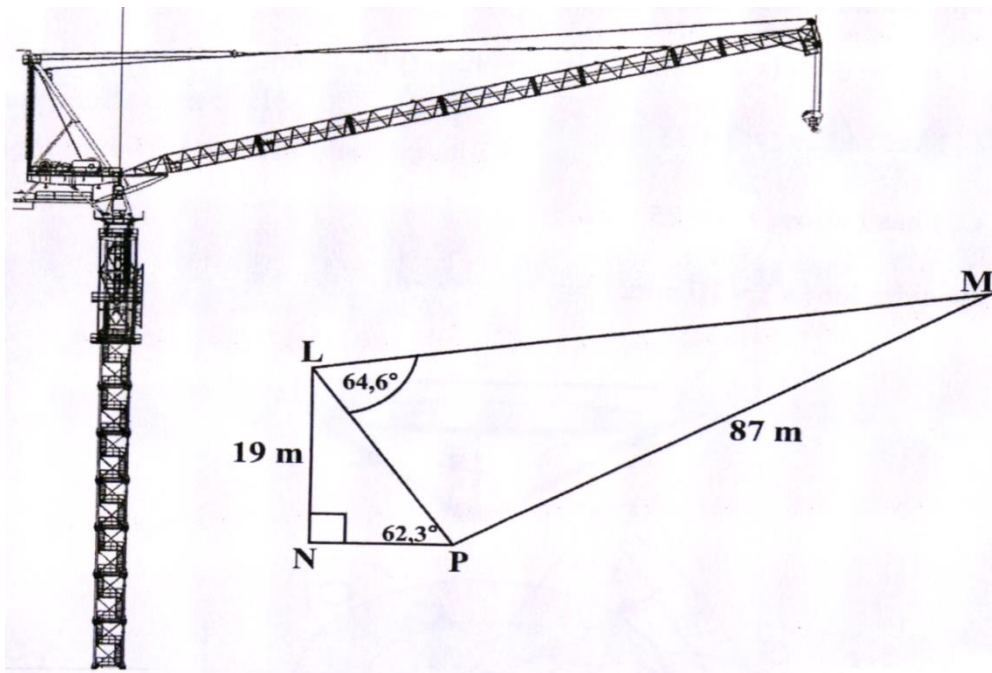

1) Prove that $\widehat{M} = 12,9^\circ$ (5)

2) Calculate the area of $\triangle LMP$, correct to the nearest whole number. (4)

[14]

QUESTION 9:

The Mathematics marks attained by a group of pupils is given below.

56	82	60	87	75	51	94	88
93	67	39	73	70	68	72	65

- a) Represent the data in a box-and-whisker plot, using the number line given below. (5)

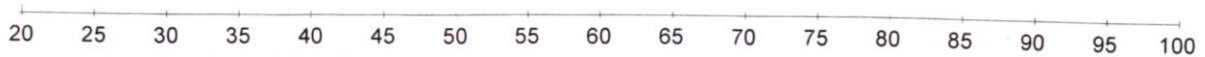

- b) By determining the mean of the data, discuss whether the results are skewed, giving a reason for your answer. (3)

c) Determine the standard deviation of the data set. (2)

d) What percentage of marks lie within 1 standard deviation of the mean? (4)

e) If 5 marks were added to all the data above, how will the mean and standard deviation be influenced? (2)

[16]

QUESTION 10: [Give reasons with all statements]

In the figure AC and CR are tangents to the circle at B and R. O is the centre of the circle. B, R, K, S and D are points on the circumference. $BE \perp CD$ and $\hat{B}_1 = x$. BK is a diameter and $CD \parallel KR$.

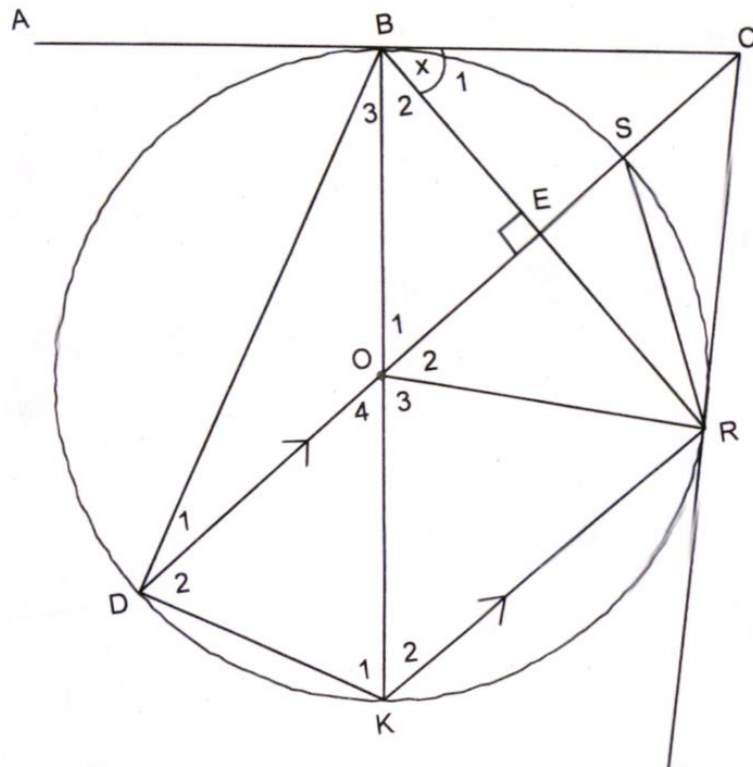

- a) Find other angles equal to x . (6)

b) Determine the value of \hat{B}_3 in terms of x . (2)

c) Prove that BCRO is a cyclic quadrilateral. (3)

d) Prove that ABC is a tangent to the circle through B, O and E. (3)

[14]

QUESTION 11: [Give reasons with all statements]

In the given diagram, BME is the diameter of circle centre M and FE is a tangent to the circle at E. Secant FDA is drawn such that DE = DF. Chord AC cuts BE at G and MD cuts EC at H. $\hat{F} = x$

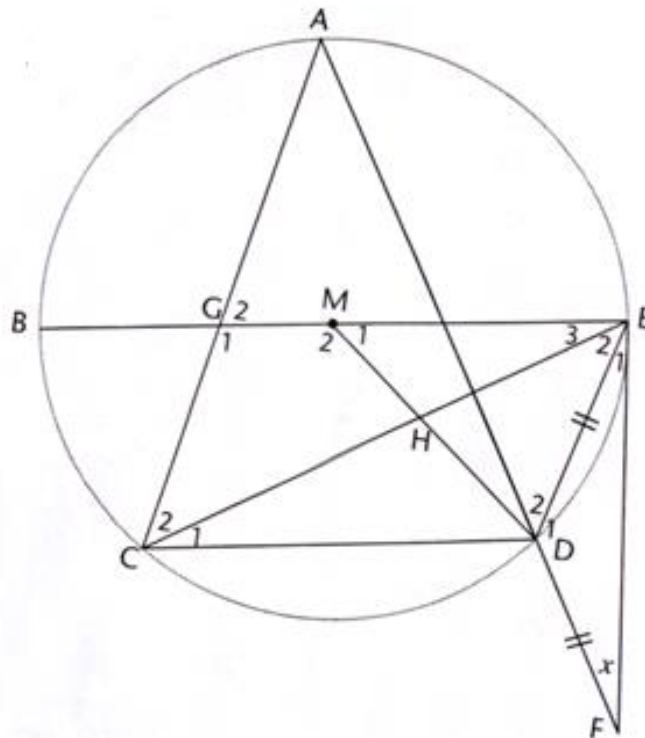

- a) Determine \hat{D}_2 in terms of x . (4)

- b) Prove that $\hat{C}_2 = 2\hat{C}_1$ (4)

[8]

QUESTION 12:

In the diagram the co-ordinates $B(6\frac{1}{2}; -2)$, $C(5; y)$, $D(-2\frac{1}{2}; 2)$ and $E(2; 5)$ are given.

E is any point on DC and A is the centre of the circle. If B , C and D lie on the circle:

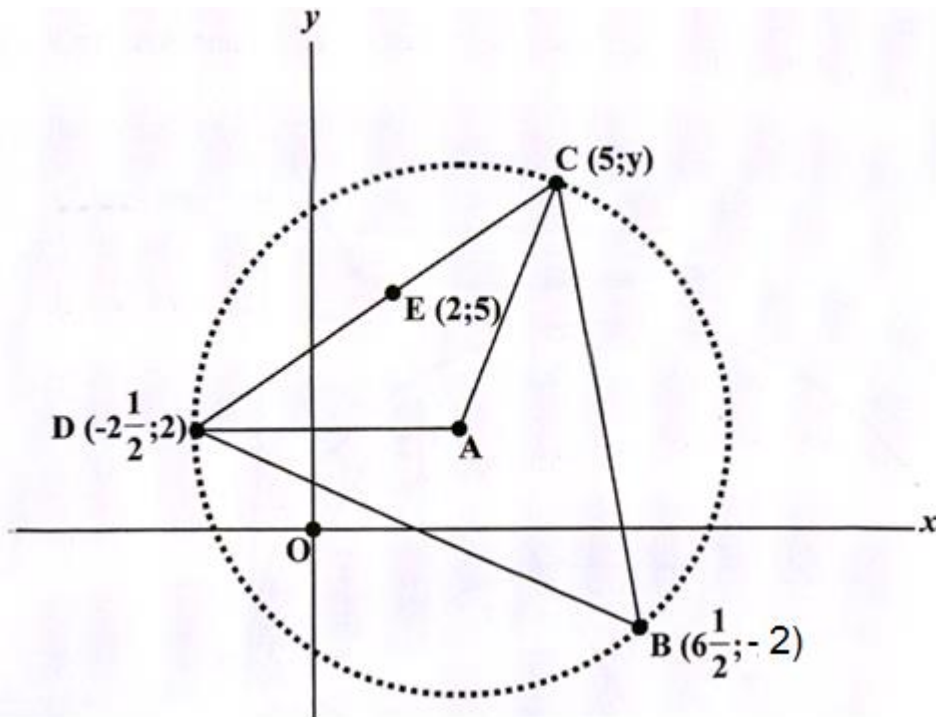

- a) Show that $C(5; 7)$ (5)

b) Use analytical methods to calculate \hat{B} . (6)

c) If DA is parallel to the x-axis

1) Write down the co-ordinates of A in terms of x. (1)

2) Hence find the value of x. (4)

[16]

MATHEMATICS: INFORMATION SHEET:

GRADE 11 / FORM 4

$$A = P(1 + i.n)$$

$$A = P(1 - i.n)$$

$$A = P(1 + i)^n$$

$$A = P(1 - i)^n$$

$$P(A) = \frac{n(A)}{n(S)}$$

$$P(A \text{ or } B) = P(A) + P(B) - P(A \text{ and } B)$$

$$d = \sqrt{(x_2 - x_1)^2 + (y_2 - y_1)^2}$$

$$M \left(\frac{x_1 + x_2}{2}, \frac{y_1 + y_2}{2} \right)$$

$$y = mx + c$$

$$y - y_1 = m(x - x_1)$$

$$m = \frac{y_2 - y_1}{x_2 - x_1}$$

$$\bar{x} = \frac{\sum fx}{n}$$