



**GAUTENG DEPARTMENT OF EDUCATION
PROVINCIAL EXAMINATION
NOVEMBER 2017
GRADE 6**

MATHEMATICS

DISTRICT _____

SCHOOL NAME _____

CLASS (e.g. 6A) _____

NAME & SURNAME _____

16 pages

**GAUTENG DEPARTMENT OF EDUCATION
PROVINCIAL EXAMINATION**

MATHEMATICS

TIME: 90 minutes

MARKS: 75

INSTRUCTIONS

1. Read all the instructions carefully.
2. Question 1 consists of 10 multiple-choice questions. Circle the letter of the correct answer.
3. Answer questions 2 to 20 in the spaces or frames provided.
4. All calculations must be shown on the question paper and may not be done on separate rough paper.
5. Write neatly and legibly.
6. The use of a calculator is not allowed.

1 Circle the letter of the correct answer.

1.1 What is 853 951 rounded off to the nearest 100?

- A 854 000
- B 854 100
- C 853 900
- D 853 950

(1)

1.2 Which statement correctly describes the movement from point A to point B on the grid?

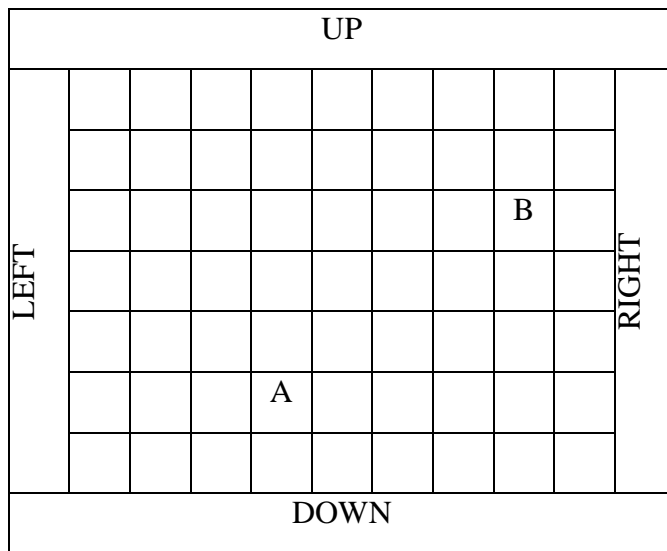

- A 2 Spaces up and 4 spaces to the right
- B 4 Spaces up and 3 spaces to the right
- C 3 Spaces down and 4 spaces to the left
- D 3 Spaces up and 4 spaces to the right

(1)

1.3 Write as a whole number:

$$(6 \times 100) + (9 \times 1\,000\,000) + (4 \times 10) + (8 \times 1\,000)$$

- A 9 008 640
- B 6 948 000
- C 9 648
- D 9 800 640

(1)

1.4 Which number sentence is equivalent to 76×24 ?

A $70 \times 20 + 70 \times 4$

B $76 \times 10 + 76 \times 14$

C $76 \times 30 + 76 \times 4$

D $70 \times 20 + 6 \times 4$

(1)

1.5 The temperature at 8 in the morning was 15 degrees Celsius. By 4 p.m. the temperature was 9 degrees Celsius warmer. What was the temperature at 4 p.m.?

A 15 degrees Celsius

B 9 degrees Celsius

C 24 degrees Celsius

D 8 hours

(1)

1.6 The grid shown below is made up of equal squares. What percentage of this grid is shaded?

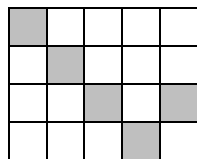

A 5%

B 25%

C 20%

D 75%

(1)

1.7 What kind of angle is shown below?

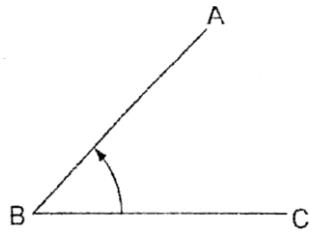

- A An acute angle
- B An obtuse angle
- C A reflex angle
- D A right angle

(1)

1.8 Which of the following spinners has the highest chance of landing on a 5?

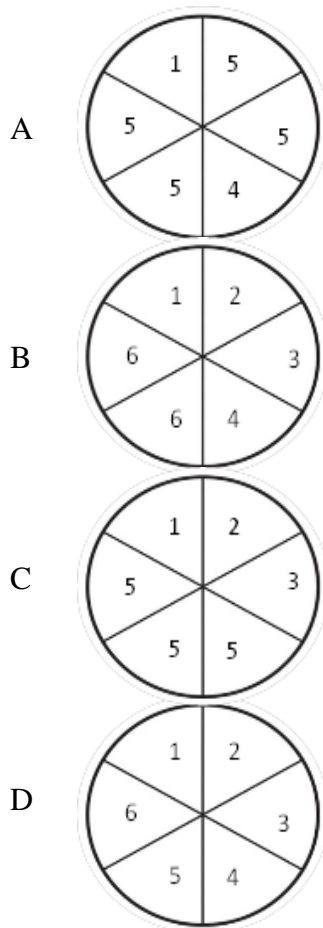

(1)

- 1.9 What is the median in the following data set?
 55 ; 67 ; 75 ; 42 ; 75 ; 19 ; 88 ; 31 ; 8 ; 75 ; 12
- A 88
 B 75
 C 19
 D 55
- (1)

- 1.10 What is the mode for the following set of data?
 12 ; 17 ; 17 ; 12 ; 30 ; 25 ; 17 ; 10 ; 26 ; 18 ; 20
- A 30
 B 25
 C 12
 D 17
- (1)
- [10]**

2 Answer the following questions in the spaces provided.

- 2.1 What is the prime factor of 27?
- _____ (1)

- 2.2 What are the first 2 multiples of 45?
- _____ (2)

- 2.3 Which 2 prime numbers are found between 60 and 70?
- _____ (2)
- [5]**

3 Calculate the answers for questions 3.1 to 3.10. Use any method. Show your steps.

3.1 $12\,573\,005 + 9\,815\,832$

(2)

3.2 $28\,833\,956 - 14\,357\,321$

(2)

3.3 $6\,822 \times 24$

(3)

3.4 $9\,832 \div 45$

(3)

3.5

$$30 + 5 \times 2$$

(2)

3.6

$$\frac{2}{3} + \frac{1}{9} =$$

(2)

3.7

$$5\frac{2}{5} - 2\frac{4}{5} =$$

(2)

3.8

$$\frac{4}{5} \text{ of } 140$$

(2)

3.9 $7,58 + 4,16 =$

(2)

3.10 $13,45 \times 100 =$

(1)

[21]

4 Fill in the missing equivalent fraction, decimal and percentage in the spaces below.

Fraction	Decimal	Percentage
$\frac{2}{10}$		20%
$\frac{3}{5}$	0,6	
	0,25	25%

[3]

5 Complete the table based on the 3-D object below.

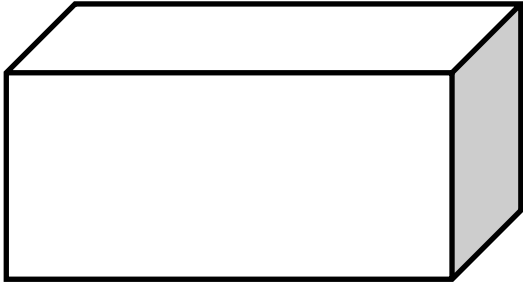
	
Name of 3-D object:	
Number of vertices:	
Number of faces:	

[3]

6 Name the 2-D shape that is described in each statement:

6.1 A quadrilateral with opposite sides equal, 2 acute and 2 obtuse angles

(1)

6.2 A shape with 8 sides

(1)

[2]

7 Draw the line or lines of symmetry in the following picture.

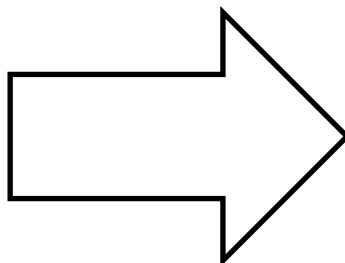

[1]

8 Draw the top view of the following diagram:

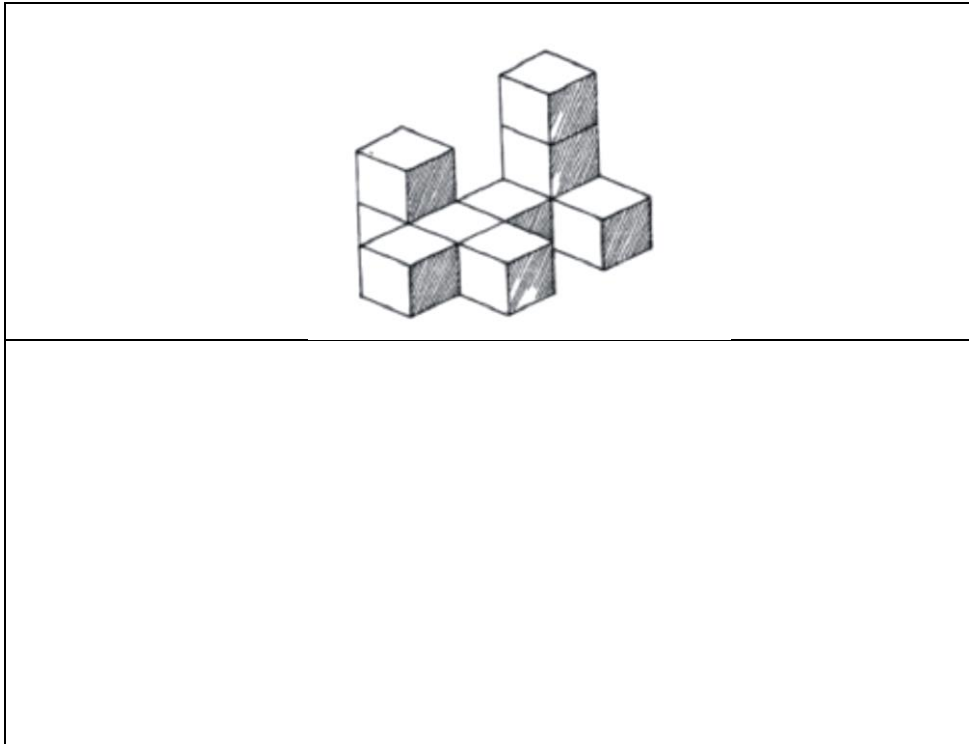

[1]

9 What transformation is taking place in this diagram?

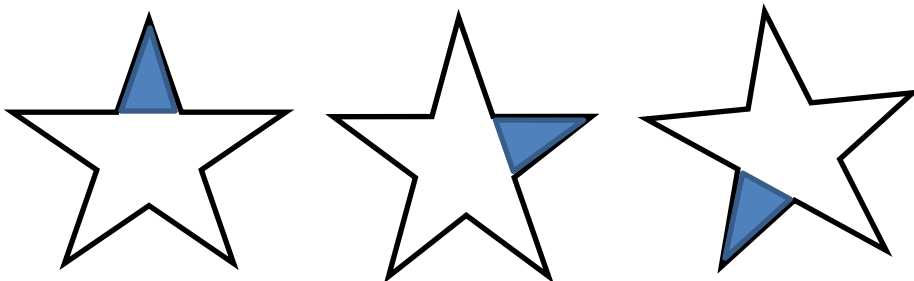

[1]

10 Convert the following measurements to the units shown.

10.1 $8\ 300\text{g} = \underline{\hspace{2cm}} \text{kg}$ (1)

10.2 $7,05 \ell \text{ (litres)} = \underline{\hspace{2cm}} \text{m } \ell$ (1)

10.3 $4 \text{ centuries} = \underline{\hspace{2cm}} \text{decades}$ (1)

[3]

- 11 Thabo buys a rope that is 4,3 m long. He cuts off a piece that is 80 cm long. What length of the rope is still left?

[2]

- 12 Zanele had Maths and English homework to do. She started doing her homework at 4:30 p.m. It took her 35 minutes to do her Maths homework and 40 minutes to do her English homework. At what time did she finish doing her homework?

[2]

- 13 13.1 What is the perimeter of this shape if each block is 1 cm long and 1 cm wide?

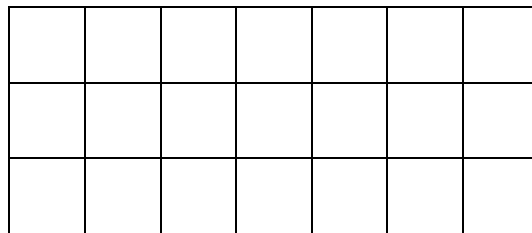

(1)

- 13.2 Paul's bedroom is in the shape of a rectangle. It is 4 m long and 3 m wide. His mother wants to buy tiles that are each 1 m long and 1 m wide to completely cover the floor of his bedroom. How many tiles does she need to buy?

(2)
[3]

14 Complete the following table showing the number of desks needed for classrooms.

Number of classrooms in a school	1	2	3	5	
Total number of desks needed	20	40	60		300

[2]

15 The diagram pattern below shows the number of bricks placed around flower-beds.

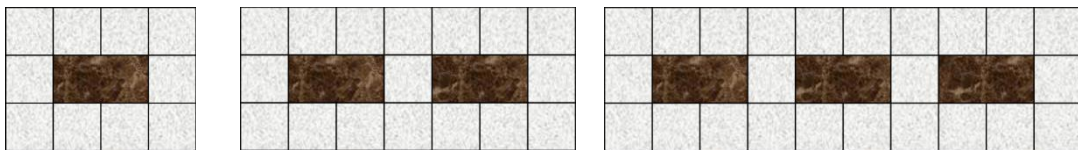

1 flower-bed

2 flower beds

3 flower beds

15.1 How many bricks will be needed if there are 4 flower beds?

(1)

15.2 How many flower beds will there be in a garden with 80 bricks?

(1)

[2]

16 Answer the questions based on the pie chart.

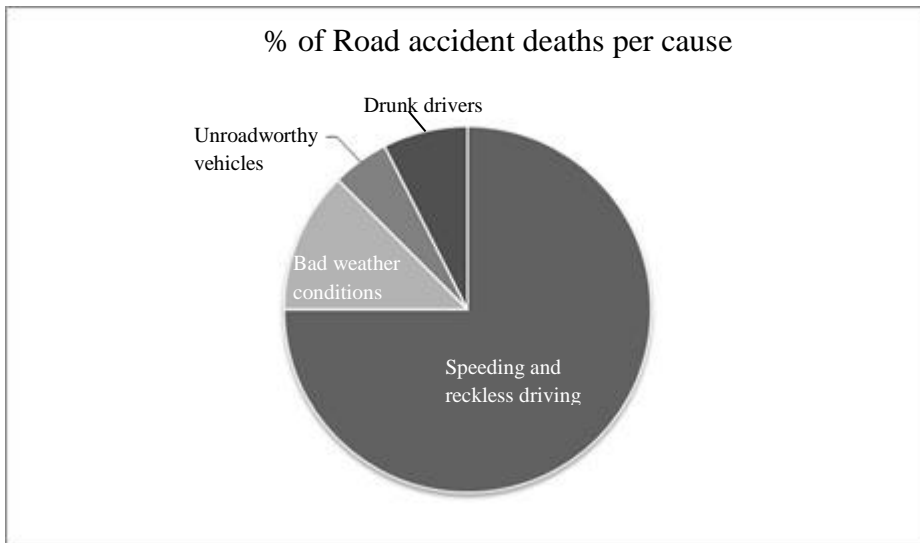

- 16.1 What is the leading cause of road accident deaths according to the graph?
 _____ (1)
- 16.2 What fraction of the road accident deaths are caused by drunk driving and unroadworthy vehicles combined?
 _____ (1)
- 16.3 What percentage of road accident deaths are caused by speeding and reckless driving?
 _____ (2)

[4]

- 17 The table below shows the rainfall in Johannesburg for 5 different months. Draw a bar graph to show this information.

Month	January	April	July	October	December
Rainfall in mm	145	45	10	60	140

Title: _____

[3]

- 18 Andrew earns R600 in a month by washing his neighbours' cars and cutting grass. He spends 20% of the money on movies. How much does he have left?

[2]

19 Thando enjoys making and selling necklaces. She is able to make 14 necklaces in an hour.

19.1 How many necklaces will Thando be able to make in $3\frac{1}{2}$ hours?

(2)

19.2 Thando makes the necklaces with beads. For every 3 red beads, she adds 2 yellow beads. How many yellow beads will she add to 9 red beads?

(1)

[3]

20 In the diagram below, the mass of the two cylinders is equal and the mass of the two cubes is also equal.

If the mass of the cone in this diagram is 6 kg. What is the mass of one cylinder?

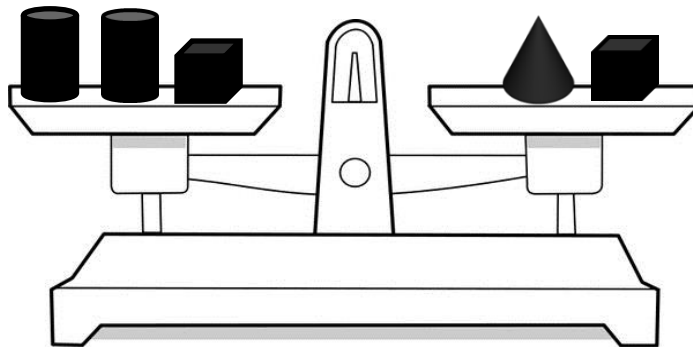

[2]

TOTAL: 75