

Further Education and Training

Grade 12 (FET)

BRIGHT IDEAS

MATHEMATICAL LITERACY

Revision Booklet

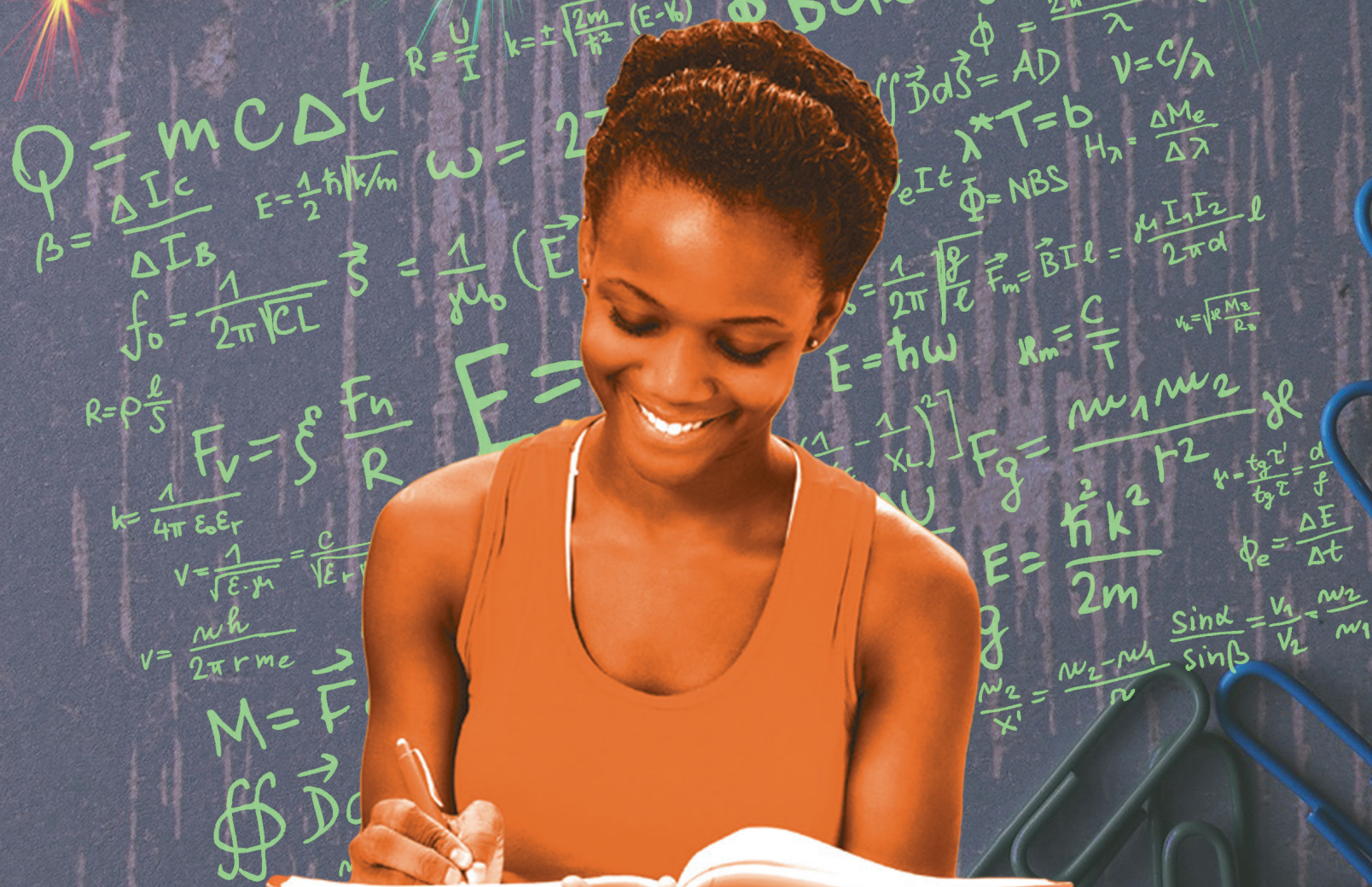

basic education

Department:
Basic Education
REPUBLIC OF SOUTH AFRICA





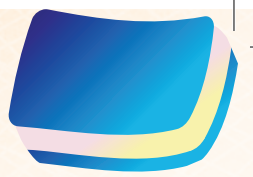
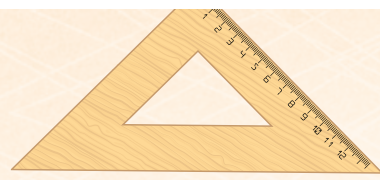

MATHEMATICAL LITERACY

Grade 12

REVISION BOOKLET

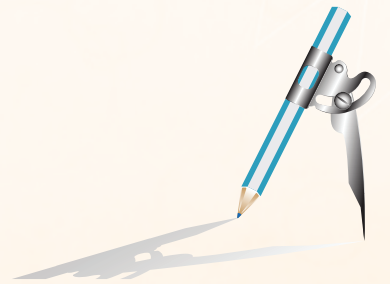

32%



History

Mathematics



Physics

Accounting

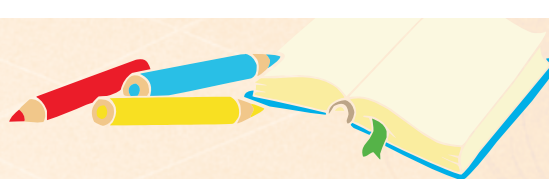
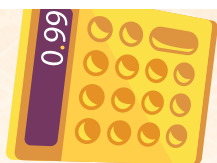
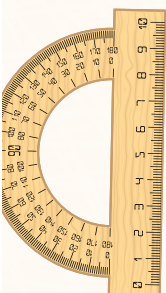
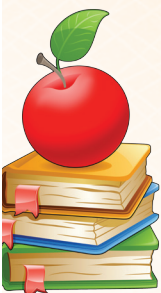
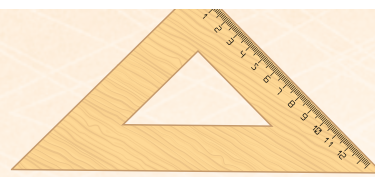

TABLE OF CONTENTS

1	FOREWORD	3
2	HOW TO USE THIS REVISION BOOKLET	4
3	KEY TOPICS COVERED	5
3.1	FINANCE	5
3.1.1	Exemplar Questions on Finance	10
3.1.2	Possible Solutions for Finance	19
3.2	MAPS, PLANS AND REPRESENTATION OF THE PHYSICAL WORLD	25
3.2.1	Exemplar Questions for Maps plans and representation of the physical world	27
3.2.2	Possible answers to the questions for the section on Maps, plans and representation of the physical world	40
3.3	MEASUREMENT	44
3.3.1	Exemplar Questions for Measurement	47
3.3.2	Possible Solutions for Measurement	56
3.4	DATA-HANDLING	62
3.4.1	Exemplar Questions for Data Handling	65
3.4.2	Possible Answers for Data Handling	72
4	STUDY AND EXAMINATION TIPS	79
5	MESSAGE TO GRADE 12 LEARNERS FROM THE WRITERS	81
6	CONCLUDING REMARKS AND ACKNOWLEDGEMENTS	82





1 FOREWORD

Message to Grade 12 learners from the Minister of Basic Education



“Matric” (Grade12) is perhaps the most important examination you will prepare for. It is the gateway to your future; it is the means to enter tertiary institutions; it is your opportunity to create the career of your dreams.

It is not easy to accomplish but it can be done with hard work and dedication; with prioritising your time and effort to ensure that you cover as much content as possible in order to be well prepared for the examinations.

I cannot stress the importance and value of revision in preparing for the examinations. Once you have covered all the content and topics, you should start working through the past examination papers; thereafter check your answers with the memoranda. If your answers are not correct, go back to the *Mind the Gap Series* and work through the content again. Retest yourself. Continue with this process until you get all the answers right.

The **Bright Idea....getting exam ready Booklet** will allow you to do this in a systemic way. It has been developed to assist you to achieve a minimum of 40% in the examinations, if you work hard and follow the advice and guidance provided in the book. I also urge you to continue with the next section that deals with an additional 20%, which will ensure you have covered the basics to achieve 60%.

Use this valuable resource which has been developed especially for YOU, work hard, persevere, work every day, read and write every day to ensure that you are successful.

I have faith that you can do this. Remember “SUCCESS” depends on the second letter, “U”.

Best Wishes

**MRS AM MOTSHEKGA, MP
MINISTER OF BASIC EDUCATION**

DATE: 24/02/2017

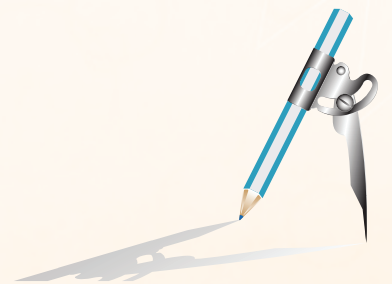

32%



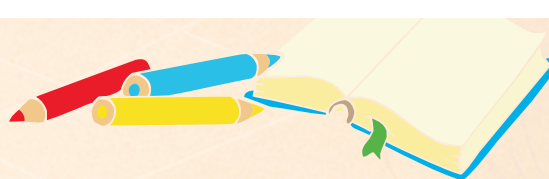
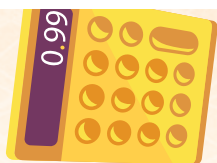

2 HOW TO USE THIS REVISION BOOKLET

- This revision booklet covers selected parts of the following Mathematical Literacy topics:
 - Finance
 - Measurement
 - Maps, plans and other representations of the physical world
 - Data handling
 - Probability (integrated across all topics)
- The topics are drawn from the CAPS Grade 12 curriculum in the order they are usually taught during the year. Selected parts of each topic are presented in the following way:
 - What you should know and an explanation of terms and concepts.
 - Model examination questions for you to answer.
 - Model answers to check your own work plus handy tips that will also assist you to succeed in the examination.
- Mathematical Literacy is naturally a highly contextualised subject. Whilst every effort has been taken to ensure that the skills and concepts you will be examined on are covered in this booklet, it is in fact the context used in the examination that will determine how these skills and concepts are assessed.
- The booklet covers mainly cognitive level 1 and 2 questions on a 50-50 basis, with a few questions pitched at cognitive level 3. Mastery of all the questions in the booklet will therefore guarantee a minimum pass of 60% in the subject, as cognitive level 1 and 2 questions in the two papers combined constitute 60% of the questions.
- Work out the solutions to the entire question on your own. Then check your answers.
- Read the tips in the textbox for further clarification.
- Reward yourself for things you get right.
- If any of your answers are incorrect, make sure you understand where you went wrong, before moving on to the next section.
- The booklet covers both generic and subject specific examination tips.. You are expected to read and understand the tips, so that you are able to study more effectively.
- The design of this revision booklet is to a large extent informed by challenges identified through analysis of learner responses to the 2016 National Senior Certificate (NSC) examination papers.



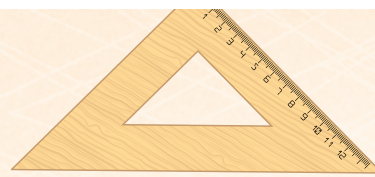

3 KEY TOPICS COVERED

3.1 FINANCE

Make sure you are able to:

- Define (explain the meaning of) financial terms.
- Calculate total income/ expenses from a given set of amounts and analyse the break-even point.
- Calculate profit/loss if income and expenses are both given.
- Substitute into a given formula.
- Do rounding for the given context.
- Read information directly from a financial table.
- Calculate simple interest and compound interest without using a formula.
- Increase or decrease a given amount by a certain percentage.
- Calculate a one-step currency fluctuation and exchange rates.
- Identify the exchange rate of two currencies from the table.
- Show awareness of the significance of digits.
- Calculate PAYE/personal tax.



32%



History
Mathematics



Physics
Accounting

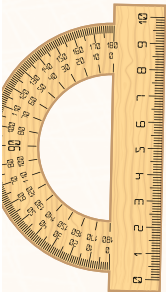
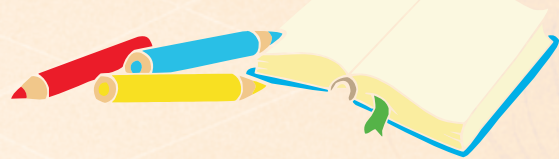
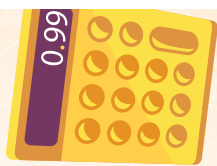

TERM	MEANING
A	
Account	A record of income and expenditure.
B	
Balance	This is the difference between debits and credits.
Bank statement	The details of all the transactions made from one bank account in a given time period.
Break-even point	Break-even point is where the business is at an activity level (doing business) at which total cost = total sales , i.e. you have made enough income to cover the costs. At the break-even point, you are making neither a profit nor a loss; from that point on you will be making a profit with each sale (until new costs are incurred).
Budget	A plan of how to spend money. An estimate of income and expenditure.
Bursary	A sum of money given to you by an organisation to cover the cost of your formal studies.
C	
Capital	Money that is owned by someone and used for the purpose of investing or lending.
Commission	The sum of money paid to an agent (usually a salesperson) that is a percentage of the total value of goods sold by the agent.
Compound interest	Interest charged on an amount due, but including interest charges to date.
Consumption rate	The rate at which a commodity, such as water, electricity or fuel, is consumed.
Cost-effective	Best value for money.
Cost price	This is the amount that it costs per unit to either manufacture or purchase an item or to prepare for a service that will be delivered. This amount is pure cost, no mark-up or profit has been added yet.
Cost rate	The price of a product per mass, volume, length or time unit.
Credit	This is an entry in an account that shows a payment made into the account.
Credit balance	The amount in the account is your own.
Credit card	<ul style="list-style-type: none"> A credit card is a service bank product that allows you to buy goods and pay for them at the end of the month.
Credit limit	The maximum amount you can spend on your credit card.
D	
Debit	<ul style="list-style-type: none"> When someone or an organisation takes money out of your account. An entry in an account showing a payment made from an account.
Debit balance	The amount owed to a lender or seller.
Debit order	It is an arrangement whereby you give permission to a third party to withdraw money from bank account on a regular basis.
Deposit	A payment made into a bank account.
Disposable income	Income that is left over after all payments have been made.





E	
Exchange rate	The value of one currency relative to the value of another currency.
Expenditure	An amount of money that is spent on something.
F	
Fine print	The legal terms and conditions printed on a contract applicable to a transaction or account.
Fixed deposit	A single deposit invested for a fixed period at a fixed interest rate.
Fixed expenses	These are amounts that must be paid every month and which stay the same, like rent, school fees and transport costs.
Fund	A source of money.
G	
Gross income	The total amount of all an individual's income before deductions.
H	
Hire purchase	Goods and products such as furniture can be purchased using a longer term lease or hire agreement (hire purchase); insurance is usually also added to the amount payable until it is paid off.
I	
Inflation	An increase in the price of a basket of goods or services that is representative of the economy as a whole.
Interest	Money paid regularly at a particular rate for the use or loan of money. It can be paid to you by a finance organisation or bank (in case of savings); or it may be payable by you to a finance organisation on money you borrowed from the organisation.
Interest rate value	This is the % rate of interest that will be charged on your loan amount, i.e. a percentage value of the original loan amount.
Interest value	This is the actual rand amount of interest that will be added to your loan.
Invest	To put money into an organisation or bank (e.g. by buying shares), so as to gain interest on the amount at a higher rate.
Investment	Something in which you have invested money.
Invoice	A comprehensive document that details all the work done or items sold, and what costs are due.
L	
Lay-by	It is a form of credit where the buyer pays a deposit and pays the balance in instalments while the shop keeps the item(s) until it has been paid off.



32%



Arithmetic



Accounting

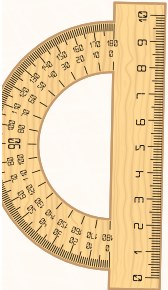
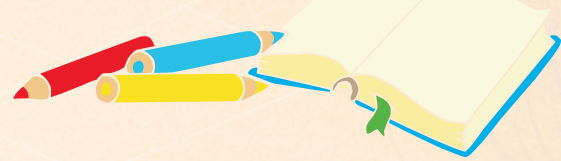
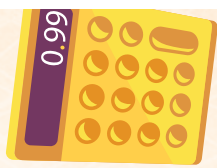

Loan	A loan is an agreed sum of money that is lent by a bank or moneylender (e.g. personal loan or home loan).
Luxury item or service	An item or service that is not essential for daily life, but which makes life easier or more convenient.
N	
Net pay	The amount an employee “takes home” after income tax has been deducted.
O	
Overdraft	An overdraft is an arrangement you make with the bank that allows you to draw more money than there is in your account.
P	
PAYE	(abbr.) Pay as you earn: tax taken off your earnings by your employer and sent to the South African Revenue Service before you are paid (the balance).
R	
Remittance slip	A piece of paper that accompanies a payment and contains the most important details of the transaction.
S	
Salary	An amount of money paid for the work you do. (This is normally paid monthly.)
Selling price	This is the price at which something is offered for sale.
Simple interest	Interest charged on the original amount due only, resulting in the same fee every time.
Statement	A summary of transactions (debits and credits, or payments and receipts) made on an account.
T	
Tariff	The rate charged for a service rendered, e.g. import duties, water consumption cost, etc.
Tax	A compulsory levy imposed on citizen’s earnings or purchases to fund the activities of government.
Taxable	A service, purchase or item or earning that has tax applied to it.
Tax invoice	Printed record of what was bought, what it cost, what was taxable, the tax amount, method of payment, amount tendered, and change due, if any.
Trillion	One- million- million (one followed by twelve zeros).
U	



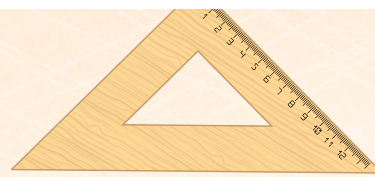

UIF	(abbr.) Unemployment Insurance Fund: A government-run insurance fund which employers and employees contribute to, so that when employees are retrenched they can collect some earnings (a portion).
V	
Variable expenses	Expenses that change over time or from one week/month to the next. These are things that you usually pay or buy each month, but the amount changes e.g. telephone and electricity costs.
VAT	Value Added Tax (VAT) is a tax that is levied at 14% (currently in South Africa) on most goods and services, as well as on the importation of goods and services into South Africa.
VAT exclusive price	The price before VAT is added.
VAT inclusive price	The price after VAT is added.
W	
Wages	A wage is an amount of money paid to an employee normally based on a fixed number of hours worked per week.
Withdrawal	Money taken out of a bank account.
Z	
Zero rated VAT items	These are goods that are exempt from VAT. Groceries that are basic foodstuffs are zero-rated in South Africa, e.g. brown bread, milk, mielie meal, samp, rice, etc..



32%



History

Mathematics



Physics

Accounting

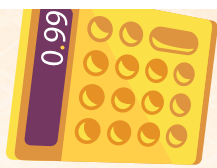

3.1.1 Exemplar Questions on Finance

Question 1

Study the monthly electricity statement below that was issued to S van Heerden.

The Mbombela Municipality		44 Swallows street			
P.O. Box 32178 Tel: (013) 752 8910					
Street Address		Client Name		Invoice Number	
Flat 3C Sonpark Heights		Mr S. Van Heerden		WEST – ELEC7810457812	
Date	Consumption Details	Tariff	Sub-Total	VAT (14%)	Total Due
29/11/16	Previous reading: 114628 kWh				
	Current reading: 115353 kWh	R0,219 per kWh	R158,78	A	R181,01

- 1.1. How many kW of electricity did Mr van Heerden use in November? (2)
- 1.2. How much VAT will Mr van Heerden have to pay for the electricity he used in November? (2)
- 1.3. Show how the *Sub-Total Charge* of R158,78 was calculated. (4)
- 1.4. Calculate the amount that Mr van Heerden paid if he has used 803 kWh of electricity in the previous month? (6)
- 1.5. Study the water tariff below from a certain municipality.

The following tariffs were used to determine the amount payable for the month of October.

CATEGORIES	RANGE	Price per kℓ (VAT excluded)
1	0 – 12 kℓ	R0, 00
2	13kℓ – 28 kℓ	R7.96
3	29 kℓ – 60 kℓ	R13.55
4	More than 60 kℓ	R16.80

- 1.5.1 What does VAT stand for? (2)
- 1.5.2 Calculate the VAT inclusive amount if: (2)
- 1.5.3 a) 28 kℓ of water was used (2)
- b) 36 kℓ of water was used (4)
- 1.6 How much will a person staying in the municipality pay if 82 kℓ. of water is used? (6)

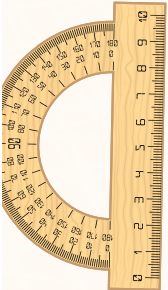

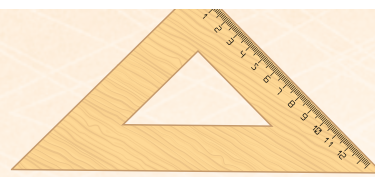

QUESTION 2

Grade 12 learners from Mollo High School are selling apples during lunch break to raise funds for their matric farewell function. They have asked the Principal to use the school tuck-shop. They bought a crate with 116 apples for R255.00 and sold them at R3.00 each.



- 2.1 Explain what is meant by break-even point? (2)
- 2.2 Calculate the profit they made, if 116 apples were sold. (2)
- 2.3 If they made a profit of R120 per day, how many: (2)
- 2.3.1 apples were sold per day? (2)
- 2.3.2 apples did they sell to break even per day? (3)
- 2.3.3 days did they take to raise an amount of R13 500.00 for the function? (3)
- 2.4 A parent of one of the learners wants to hire a car for her child's matric dance farewell. Car hire companies have different tariffs and benefits on offer. Parents will compare these offers and choose the one that will give them the best value for their money. The tariffs of two car hire companies are given below:



AVIS CAR HIRE R6,50 per kilometer



BUDGET CAR HIRE R165 plus R3,50 per kilometer

The table below shows the cost of the two options:

Kilometers travelled	10	20	40	C
Cost for Avis Car Hire	R65	A	R260	R455
Cost for Budget Car Hire	R200	R235	B	R410



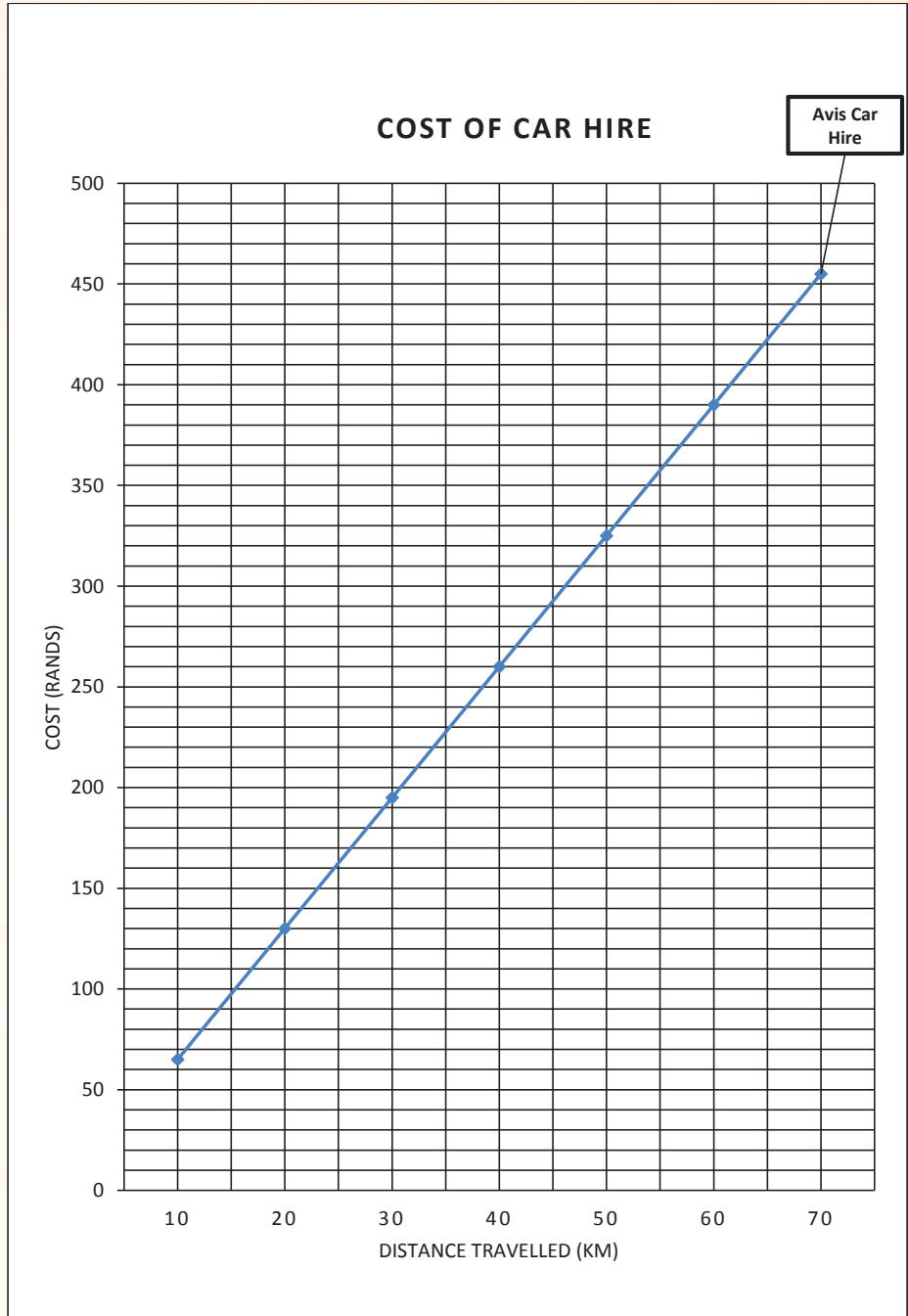
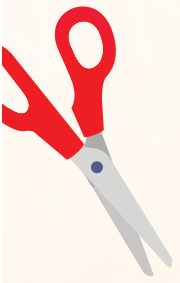
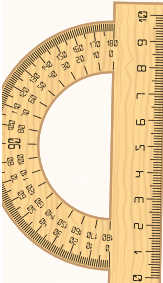
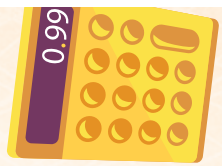

- 2.3.1 Calculate the missing values A, B and C. (6)
- 2.3.2 The graph for AVIS CAR HIRE is already drawn on the **diagram sheet below**. On the (6)
same diagram sheet, draw a graph for the cost of BUDGETCAR HIRE
- 2.4 Use the graph or table to answer the following questions:
- 2.4.1 After how many kilometres will the cost of the two companies be the same? (2)
- 2.4.2 The child wants to travel 80km on a particular day. Which car hire company would be (3)
cheaper, and by how much? Show all calculations.



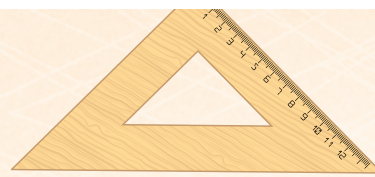

QUESTION 3

Ms Mchunu is a 56-year-old general assistant at a Lindowake firm in Ikageng; she earns a gross monthly salary of R9 857,30.

The following amounts are deducted from her monthly salary:

- Union membership R28
- Pension fund 7,5 % of gross salary
- Medical aid : $\frac{1}{3}$ of total medical aid subscription fee due as shown below.

Sindisa medical aid membership subscription fees:

Gross monthly salary	Main member	Wife/partner	Each child
R0 –R9 000	R1 345	R890	R475
R9 001 –R11 500	R1 449	R974	R519
More than R11 500	R1 643	R1 066	R559

- 3.1. Calculate her annual salary. (2)
- 3.2. Calculate her monthly pension fund contribution (2)
- 3.3. Determine her annual UIF contribution. (2)
- 3.4. Ms Mchunu is a single parent with two children; they belong to the medical fund. Use the table to calculate the monthly contribution to the medical aid. (3)
- 3.5. Calculate all the monthly deductions from Ms Mchunu's salary. (3)
- 3.6. Calculate her net salary. (3)
- 3.7. Determine her annual taxable income. (2)
- 3.8. Ms Mchunu was promoted to the position of Senior Administrator in March 2015 and she earned a taxable income of R12 053.40 per month. (3)

Determine the percentage increase of her taxable income.

You may use the formula:

Percentage increase =

Tax rates (year of assessment ending 29/02/2016)

Tax brackets	Taxable income	Rate of tax (in rand)
A	0 – 181 900	18% of taxable income
B	181 901 – 284 100	32 742 + 26% of income above 181 900
C	284 101 – 393 200	59 314 + 31% of income above 284 100
D	393 201 – 550 100	93 135 + 36% of income above 393 200
E	550 101 – 701 300	149 619 + 39% of income above 550 100
F	701 301 and above	208 587 + 41% of income above 701 300

Question 4



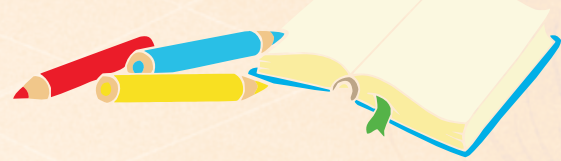
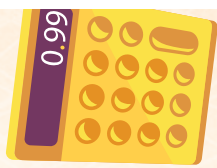

4.1 A photocopying company offers three options to clients to make payment when using their photocopying machines to make copies. The three options are shown in the graph below - ANNEXURE A.

4.1.1 Give the value of the coordinates of the point where the costs of hiring the machines are the same in contracts 2 and 3. (2)

4.1.2 Write down the formula that must be used for calculating the cost (in Rand) for contract 1. (4)

4.1.3 Use the graph to determine which contract will be the cheapest option, if a company makes 1 500 copies in one month? (2)

4.1.4 A second company charges a rate of R0,70 a page for using their copying machine. Draw a graph on ANNEXURE A, to show this option. Provide a label for the graph. (3)

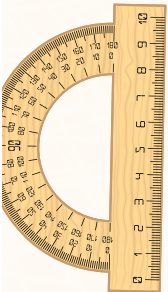

ANNEXURE A:

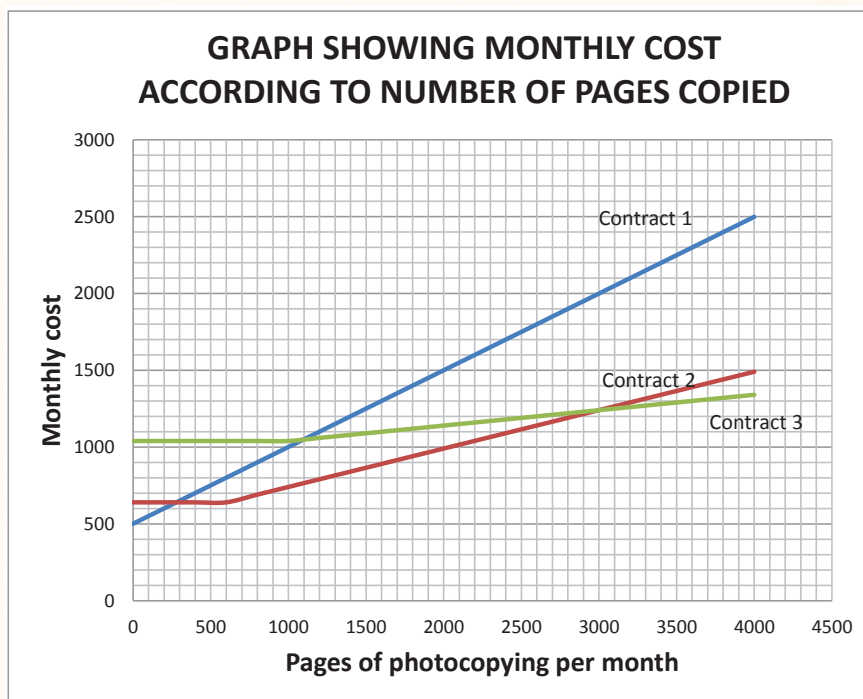

Question 5

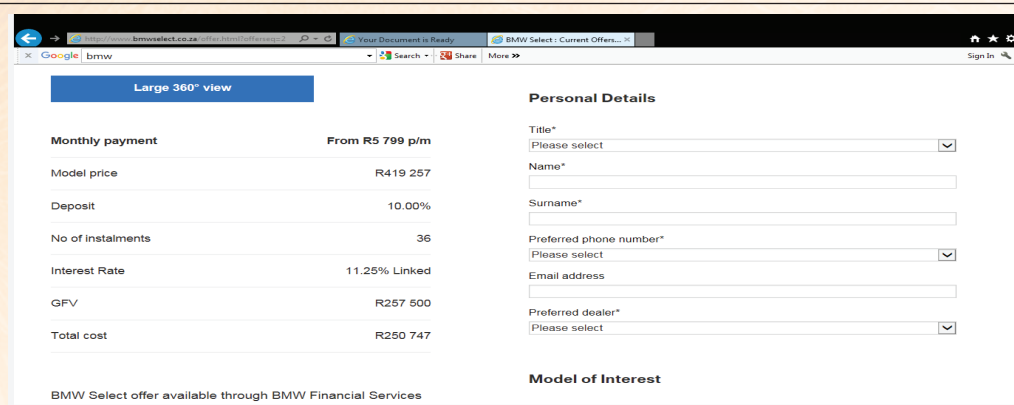

The screenshot shows a web browser displaying a BMW Select offer. On the left, a table lists financial details:

Monthly payment	From R5 799 p/m
Model price	R419 257
Deposit	10.00%
No of Instalments	36
Interest Rate	11.25% Linked
GFV	R257 500
Total cost	R250 747

Below the table, it states: "BMW Select offer available through BMW Financial Services".

On the right, there is a "Personal Details" form with the following fields:

- Title* (Please select)
- Name*
- Surname*
- Preferred phone number* (Please select)
- Email address
- Preferred dealer* (Please select)

Below the form, there is a "Model of Interest" section.

Total cost includes R1 140 initiation fee* and monthly service fees (R57 p/m); it excludes license and registration. Residual may apply subject to deal structure. Offer valid until 28 February 2017 and subject to stock availability.

*Initiation fee: the money paid by the buyer upon signing the contractual agreement.

Lelo saw the advert above and bought a car on 11 January 2017 as per the advert.

- 5.1 Explain the difference between "interest" and "interest rate". (4)
- 5.2 Determine how much she had paid for the deposit. (2)
- 5.3 Show by means of calculations how the total cost was determined, rounded to the nearest (5)
Rand.

NB: The monthly service fee is also charged upon signing the contractual agreement.

You may use the formula: Total cost = deposit + (36 x monthly repayment) + 57.

- 5.4 If she had paid 25% deposit while GFV and the total cost remained the same.
 - 5.4.1 Calculate the deposit amount paid.
 - 5.4.2 Calculate the monthly repayment, excluding the monthly service fee. Use the formula:

$$\text{monthly repayment} = \frac{\text{Total cost} - (\text{deposit})}{36}$$

Question 6

Lelo receives a tax invoice as well as an updated bank statement every month. ANNEXURE B below shows the tax invoice for 5 March 2016. Some information has been removed from the statement.

6.1. Determine:

- 6.1.1 A and B. (4)
- 6.1.2 The value of C, if C is the balance of the total cost. (3)
- 6.1.3 The value of D, if D is the interest rate exclusive of the monthly fee. (4)

ANNEXURE B	
TAX INVOICE NO: WB/97471224	
DATE: 2016/03/05	
Bank for the people	
NCR Registration No:	NCRCP001
Physical Address:	12 Jakaranda Street
	Pretoria 0001
A Division of SA Bank Limited. An Authorised and Registered Credit and Financial Services Provider.	
Telephone number: 0861 222 1212	
Fax number: 0861 222 1213	
Postal Address:	Private Bag X021
	Pretoria 0001
E-mail: service@youbank.co.za	
CUSTOMER AGREEMENT DETAILS	
Account number	7384784838
Customer name	Ms LM Chika
Description of goods	BMW 220i Sport Line
Original capital balance	R419 257,00
Instalment amount	R5 799,00
Frequency of instalment	MONTHLY
Date commenced	2016/02/02
Expiry date	A
Original term (months)	36
No. of remaining instalments	B
GFV	R257 500,
Balance	C
SUMMARY OF TRANSACTIONS FOR STATEMENT PERIOD	
Payments received	R5 799.00
Interest	D
Fees levied	R57,00
INSTALMENT DETAILS	
Instalment due date	2016/03/31

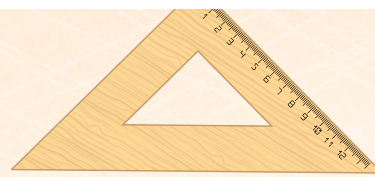

Instalment due amount	E
Advanced amount	R0,00
Arrears amount	R0,00

Question 7

7.1 Domila bought the house below in November 2015. He is currently living in the house with his family and has been paying his bond every month.



Bond Costs:

R6 381 per month

Interest rate: 10.25%

Period: 20 years

7.1.1 How much will Domila pay in total for the house in 20 years, if the interest rate remains unchanged? (3)

7.1.2 If the house cost R949 796,33, how much interest would Domila pay for the house over the 20-year period? (2)



7.2 Read the following information and use it answer questions on Domila's house:

A repurchase rate - also known as a repo rate - is the interest rate set by the South African Reserve Bank (SARB) to help banks determine the interest rate that they can charge a consumer who borrows money from them. The table below shows the current and historic values of SARB's repo rate. SARB latest interest rate/ repo rate changes:

Change date	percentage
January 28 2016	6.750%
November 19 2015	6.250%

The South African Reserve Bank met in January 2016 to increase the repo rate and because of that, Adrian's bank informed him that there will be a change to the monthly repayment fee of his house.

7.2 By how much was the repo rate increased from November 2015 to January 2016? (2)

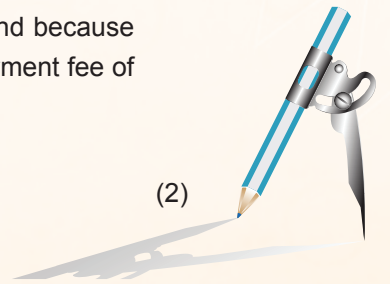

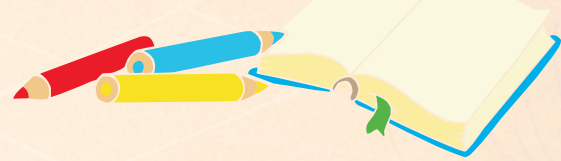
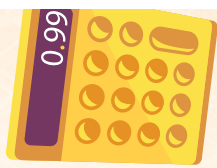

7.3 The table below is a loan factor table that shows the monthly repayments per R1 000 on a home loan with interest rates ranging from 9.75% to 11.25% per annum, over 15, 20, 25 and 30 years.

Table: Loan factor table for calculating monthly repayments on a home loan per R1 000.

Interest - %	Years			
	15	20	25	30
9.75%	10.59	9.49	8.91	8.59
10.00%	10.75	9.65	9.09	8.78
10.25%	10.90	9.82	9.26	8.96
10.50%	11.05	9.98	9.44	9.15
10.75%	11.21	10.15	9.62	9.33
11.00%	11.37	10.32	9.80	9.52
11.25%	11.52	10.49	9.98	9.71

7.3.1 If the interest rate was 10.25% before the repo rate was adjusted by 0.5%, what will the new interest rate and the new loan factor be for the 20-year period? (2)

7.3.2 Adrian's house cost R649 796,33. Determine the new monthly repayment over a 20-year period. (3)

Use the formula:

$$\text{Monthly repayment} = (\text{loan amount} \div 1000) \times \text{loan factor}$$

7.3.3 Before the increase in the interest rate, Adrian had R3 210 left after paying for the bond. How much will remain after the increase in the bond repayment amount, due to the change in the repo rate? (2)

7.3.4 What effect will the increase in the repo rate have on Domila's finances? (3)

7.3.5 In what ways will an increase in repo rate affect a consumer like Domila? Give at least two scenarios. (3)

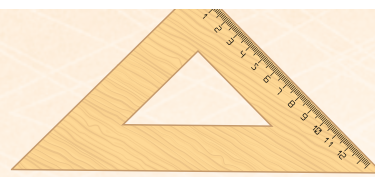

QUESTION 1

3.1.2 Possible Solutions for Finance

Question	Solution
1.1	114628 kWh 115353 kWh ✓ 725 kWh ✓
1.2	VAT = x R158.78 ✓ OR R181.01 – R158.78 = R22.33 ✓ R22.23 ✓
1.3	Total charge for consumption = R 0,219/kWh x 725 kWh ✓ ✓ = R158,78
1.4	Total charge for October = 0.219 x 803 ✓ = R175.857 ✓ VAT = X R175.857 ✓ = R 24.62 ✓ Payable amount = R175.857 + R 24.62 ✓ = R200.48 ✓
1.5.1	Value Added Tax
1.5.2 (a)	Payable amount = (12 x R0.00) + (16 x R7.96) = R0.00 + R127.36 = R127.36 × 1.14 = R145,19
1.5.2 (b)	Payable amount = (12 x R0.00) + (16 x R7.96) + (8 x R13.55) ✓ = R0.00 + R127.36 + R108.40 ✓ = R235.76 × 1.14 ✓ = R268.77 ✓
1.6	Payable amount = (12 x R0.00) + (16 x R7.96) + (32 + R13.55) ✓ + (22 x R16.80) ✓ = R0.00 + R127.36 + R433.60 + R149.60 ✓ = R710.56 ✓ He will pay R710.56 × 1.14 ✓ = R809.40 ✓

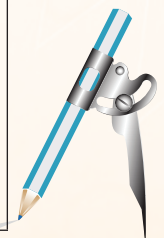

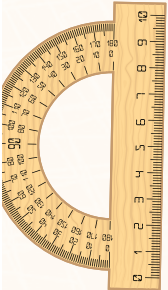
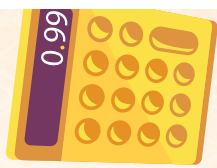

QUESTION 2

2.1	Break-even point is point where income and expenses are the same, i.e. income = costs, no profit is made✓✓																		
2.2	Cost price = R255.00 Selling price = $116 \times R3.00 = R348.00$ ✓ Profit = $R348 - R255 = R93.00$ ✓																		
2.3.1	Income = $R255 + R120 = R375.00$ ✓ Apples sold = = 125 ✓																		
2.3.2	Number of apples to break-even = = 85✓																		
2.3.3	Number of days = = 112,5 ✓ 113✓																		
2.2.1	Cost = $6,50 \times 20$ ✓ A = R130✓ Cost = $165 + 3,5 \times 40$ = $165 + 140$ B = R305✓ $455 = 6,5 \times C$ ✓ $455 \div 6,5 = C$ C = 70km✓																		
2.3	Comparison of Car hire <table border="1"> <caption>Data points from the Car Hire Comparison Graph</caption> <thead> <tr> <th>Distance (km)</th> <th>Cost for Avis Car Hire (Rand)</th> <th>Cost for Budget Car Hire (Rand)</th> </tr> </thead> <tbody> <tr> <td>10</td> <td>60</td> <td>200</td> </tr> <tr> <td>20</td> <td>130</td> <td>235</td> </tr> <tr> <td>40</td> <td>260</td> <td>305</td> </tr> <tr> <td>55</td> <td>385</td> <td>385</td> </tr> <tr> <td>70</td> <td>455</td> <td>410</td> </tr> </tbody> </table>	Distance (km)	Cost for Avis Car Hire (Rand)	Cost for Budget Car Hire (Rand)	10	60	200	20	130	235	40	260	305	55	385	385	70	455	410
Distance (km)	Cost for Avis Car Hire (Rand)	Cost for Budget Car Hire (Rand)																	
10	60	200																	
20	130	235																	
40	260	305																	
55	385	385																	
70	455	410																	
2.4.1	After 55 km✓✓																		



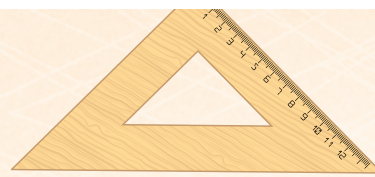

2.4.2 Avis = (6,5 × 80)
 = R520,00✓

Budget = 165 + 3,5 × 80
 = R445,00✓
 = R520 – R445
 = R75,00

Budget car hire will be cheaper by R75,00✓



QUESTION 3

- 3.1. Annual salary = R9 857,30 X 12 ✓
 = R118 287.60✓
- 3.2. Monthly pension fund contribution
 = 7.5% of R9 857,30✓
 = R737.30✓
- 3.3. Annual UIF = R118 287.60 × 1% ✓
 = R1 182,88✓
- 3.4. Medical aid contribution
 = of [R1 449+ (2 x R519)] ✓✓
 = R829✓
- 3.5. Total deductions = R737.30 + R120.00 + R920.33+ R28✓
 = R1795.63✓
- 3.6. Net Salary = R9 857,30- R1795.63✓
 = R8061.67✓
- 3.7. Taxable income = R9 857,30-(R737.30 +R10) ✓
 = R9110.00✓
 Annual taxable income = R9110.00 x 12✓
 =R109 320✓
- 3.8. Percentage increase = $\frac{\text{New taxable income}-\text{Previous taxable income}}{\text{Previous taxable income.}} \times 100\%$
 = $\frac{144636-R109320}{R109320} \times 100\%$
 = 32.3%✓



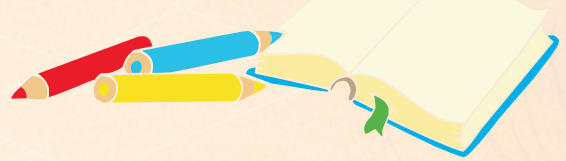
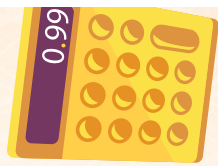

4.1.1	(1 240;3000)✓✓
4.1.2	Monthly cost = 640 ✓ + (- 600) ✓ x 0,25 ✓
4.1.3	Contract 2 ✓✓
4.1.4.	See graph below.

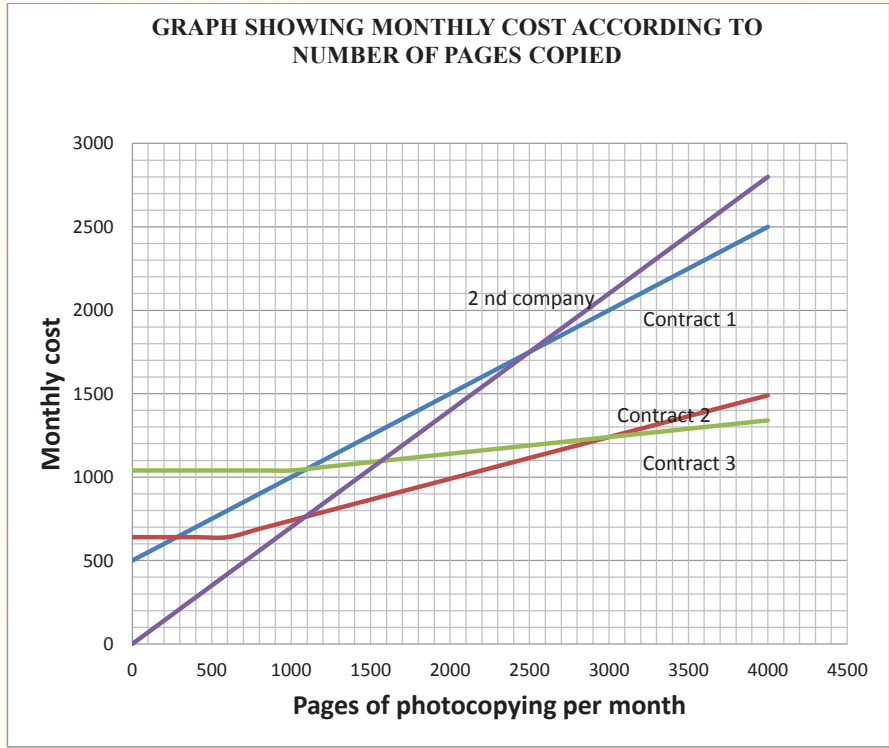
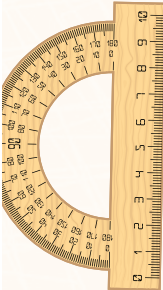

(0; 0) ✓

(1000; 700) ✓

Straight line with constant gradient ✓ (3)





5.1	<ul style="list-style-type: none"> Interest: the amount by which the money grows while being invested. Interest rate: the percentage by which an amount of money grows after being invested for one year.
5.2	$\text{Deposit paid} = R419\,257 \times 10/100$ $= R41\,925.70$
5.3	$\text{Total cost} = \text{deposit} + (36 \times \text{monthly repayment}) + 57$ $= R41\,925.70 + (36 \times R5\,799) + 57$ $= R250\,746.70$ $= R250\,747$
5.4.1	$\text{Deposit paid} = R419\,257 \times 25/100$ $= R104\,814.25$
5.4.2	$\text{monthly repayment} = \frac{R250\,746.70 - (R104\,871.25)}{36}$ $\text{monthly repayment} = R4\,052.10$
6.1.1	<p>A: 2019/01/31</p> <p>B = 35</p>
6.1.2	$\text{Balance} = R250\,747 - R5\,799$ $= R244\,948$
6.1.3	$\text{Normal repayment} = R5\,799 - R57$ $= R5\,742$ <p>March repayment = $R5\,742 \times 11.5/100$</p> $= R660.33$ <p>D = R660.33</p>



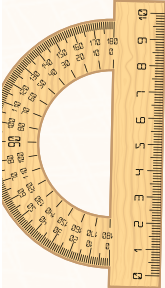
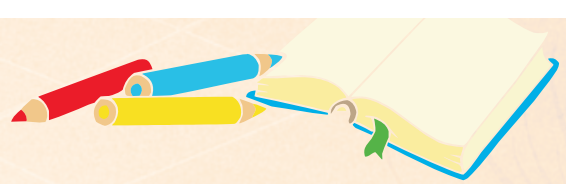
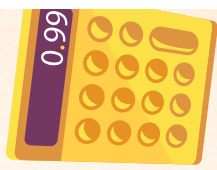

7.1.1	<p>Total repayment = $R6\ 381 \times 12 \times 20$ ✓✓</p> <p>= $R1\ 531\ 440$ ✓</p> <p>Or</p> <p>Total repayment = 6381×12</p> <p>= $R76\ 572$ ✓</p> <p>76572×20</p> <p>= $R1\ 531\ 440$ ✓✓</p>
7.1.2	<p>Interest paid = total repayment – cost of the house</p> <p>= $R1\ 531\ 440 - R949\ 796,33$ ✓</p> <p>= $R581\ 643,67$ ✓</p>
7.2	<p>Repo rate increase = $6.750\% - 6.250\%$ ✓</p> <p>= 0.50 ✓</p> <p>The repo rate has increased by 0.50.</p>
7.3.1	<p>$10.25\% + 0.5\%$</p> <p>= 10.75% ✓</p> <p>The new loan factor will be 10.75. ✓</p>
7.3.2	<p>Monthly repayment</p> <p>= $(R949\ 796,33 \div 1000) \times 10.75$ ✓✓</p> <p>= $R10\ 210,31$ ✓</p>



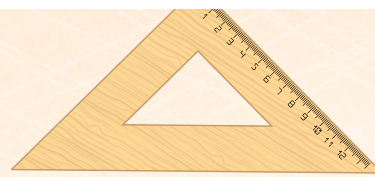

3.2 MAPS, PLANS AND REPRESENTATION OF THE PHYSICAL WORLD

Make sure you are able to:

- Use given scale to determine distances on given maps or plans.
- Determine a scale for a given plan or map.
- Use grids and maps in order to determine locations in a familiar context by applying routine procedures.
- Locate positions on maps or plans.
- Describe routes using plans or maps.
- Draw simple scale drawings where the scale is given and based on the application of simple routine procedures in a familiar context.



Glossary of terms for Maps plans and representation of the physical world

2-D models : A diagram or picture having length and width only.

2-dimensional plans : A plan or design having length and width only, but possibly representing three dimensional objects.

3-D models : A dimensional construction of real-life objects.

Bar scales : Presented as a picture, it means that if you placed a ruler next to this scale, you could determine how many centimeters represent the specified kilometers.

Compound bar graphs : Graphs that contain multiple bars for each category of data, with each bar representing a different component of each category of the data.

Elevation map : Information about the profile of a route as seen from the side.

Elevation plans : Show the design and dimensions of the outside of a building from a side view.

Floor plans : Shows the design and dimensions of the inside of a building, from a top view.

Highway : A major road that links major cities.

Line graphs : A diagram used to display data with a consistent trend.

National road map : Shows major roads linking major cities to each other.

North elevation plan : Shows the side of the building that is in front of you when you are facing the compass direction 'North'.





Number scale

: A number scale such as 1 : 50 000 means that 1 unit on the map represent 50 000 units in real life.

Route map

: Shows a specific route, for instance for an event, as seen from above.

Scale

: Determines how many times smaller an object shown on a plan or map is that its actual size.

Scale drawing

: A diagram of a real-life object drawn in proportion.

Scaled elevation plans

: Show the design and dimensions of the outside of a building from a side view using a specific scale.

Street map

: A map of a small area such as a town or city.

Strip map

: A map of a section of a travelling route.

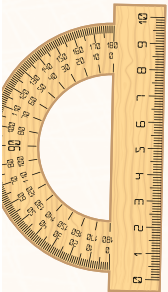

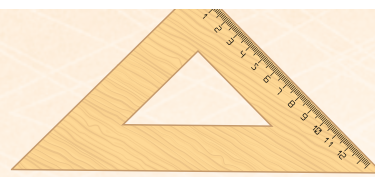

3.2.1 Exemplar Questions for Maps plans and representation of the physical world

QUESTION 1

- 1.1 The scale on a town plan is 1: 13 000. If two houses are 4,5 cm apart on the plan, calculate how far are they from each other? Write your answer in km. (3)
- 1.2 Study the layout plan below to answer the questions that follow:

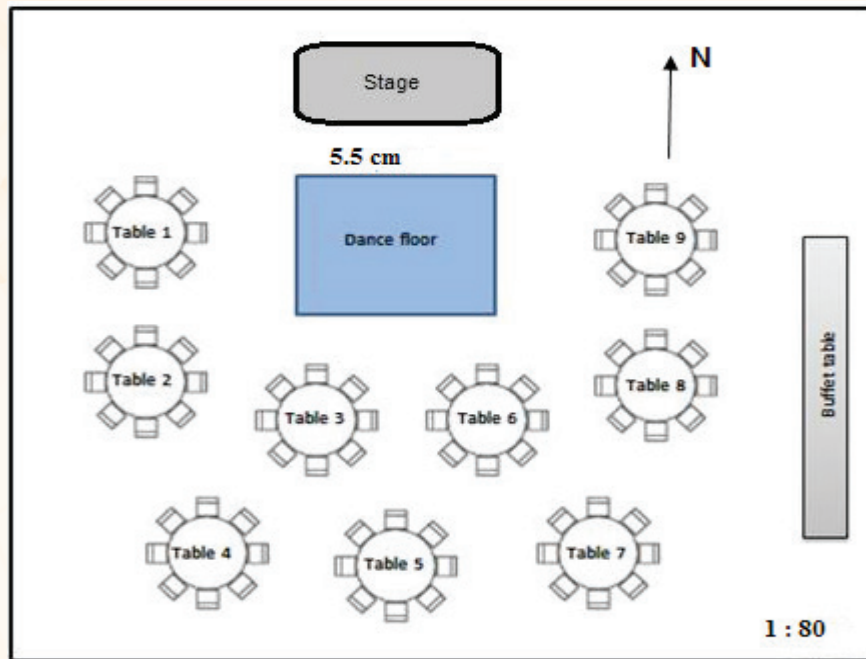

- 1.2.1 The dance floor on the diagram measures 5,5 cm across. Use the given scale to calculate the length of the dance floor in reality. (2)
- 1.2.2 Give the general position of table 9 with reference to table 5. (2)
- 1.2.3 Determine the scale of the plan if the diagram measurement of the dance floor is 4,5 cm and the actual length is 225 cm. (3)
- 1.2.4 If the actual length of the buffet table is 520 cm, determine the length of the table on the plan. (3)

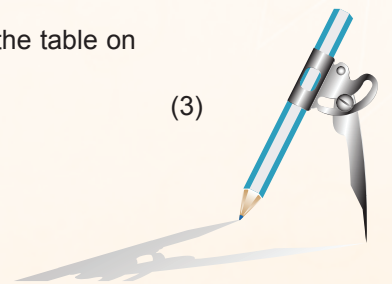

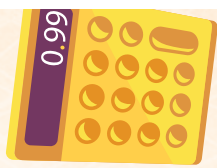

QUESTION 2

A floor plan for offices is given below. The length of the building on the plan is 11.70 cm and the width is 10.40 cm. An electrical plan is also attached to the floor plan. Use the information on **the floor plan** to answer the following questions

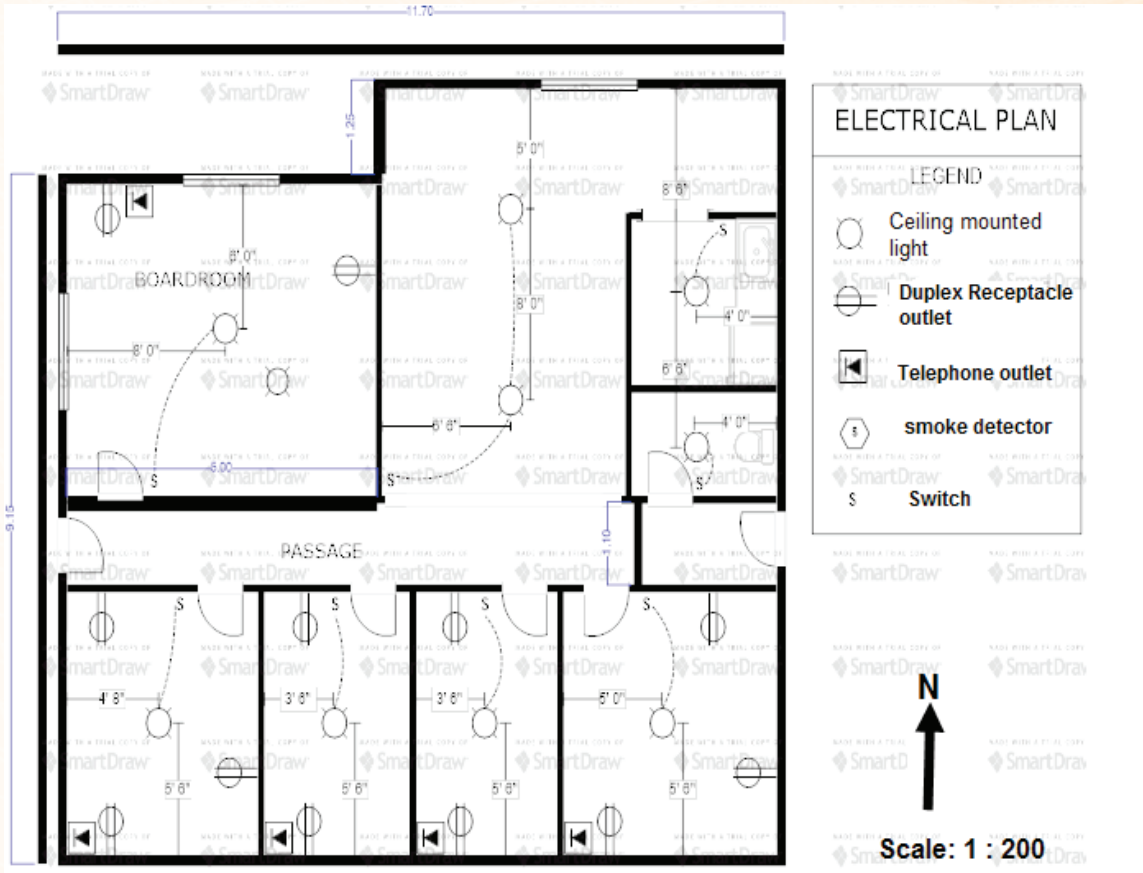

- 2.1 How many telephone outlets are in the building? (2)
- 2.2 Write down the ratio of the outside doors to the inside doors in the simplest form. (3)
- 2.3 Explain the meaning of the scale 1 : 200 on the plan. (2)
- 2.4 Use the given scale to determine the actual dimensions of the building. (3)
- 2.5 What is the probability of finding a window on the eastern wall of the offices? (2)



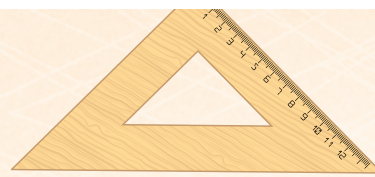

QUESTION 3

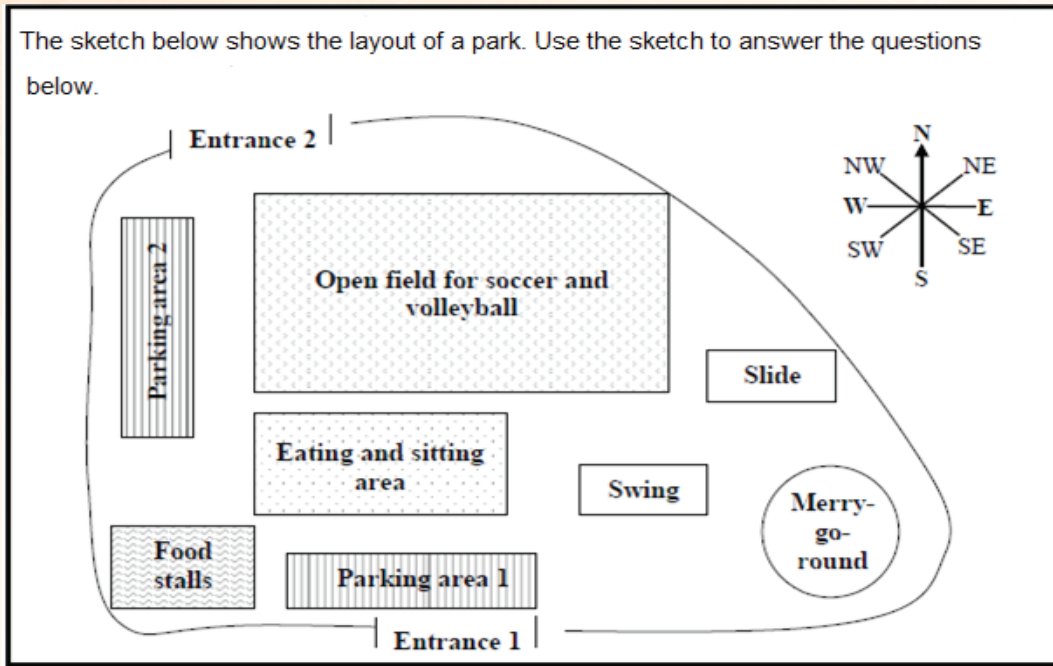

3.1 Which parking area is situated in the northwesterly direction of Entrance 1? (2)

3.2 Which playground equipment is situated in the far south-eastern direction of Entrance 2? (2)

3.3 Name any sporting facility found in the park. (2)

3.4 The actual length of Parking area 2 is 15 m and it is 6 cm when measured on the sketch. Use this information to determine the scale of the layout sketch of the park. (3)



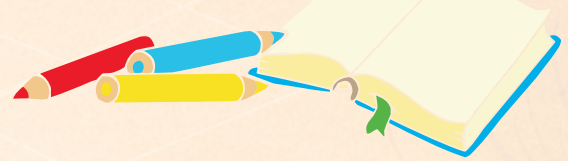
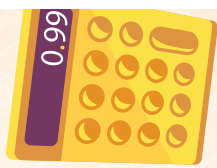

QUESTION 4

Below is the layout plan of a mall. Study it carefully then answer the questions below.

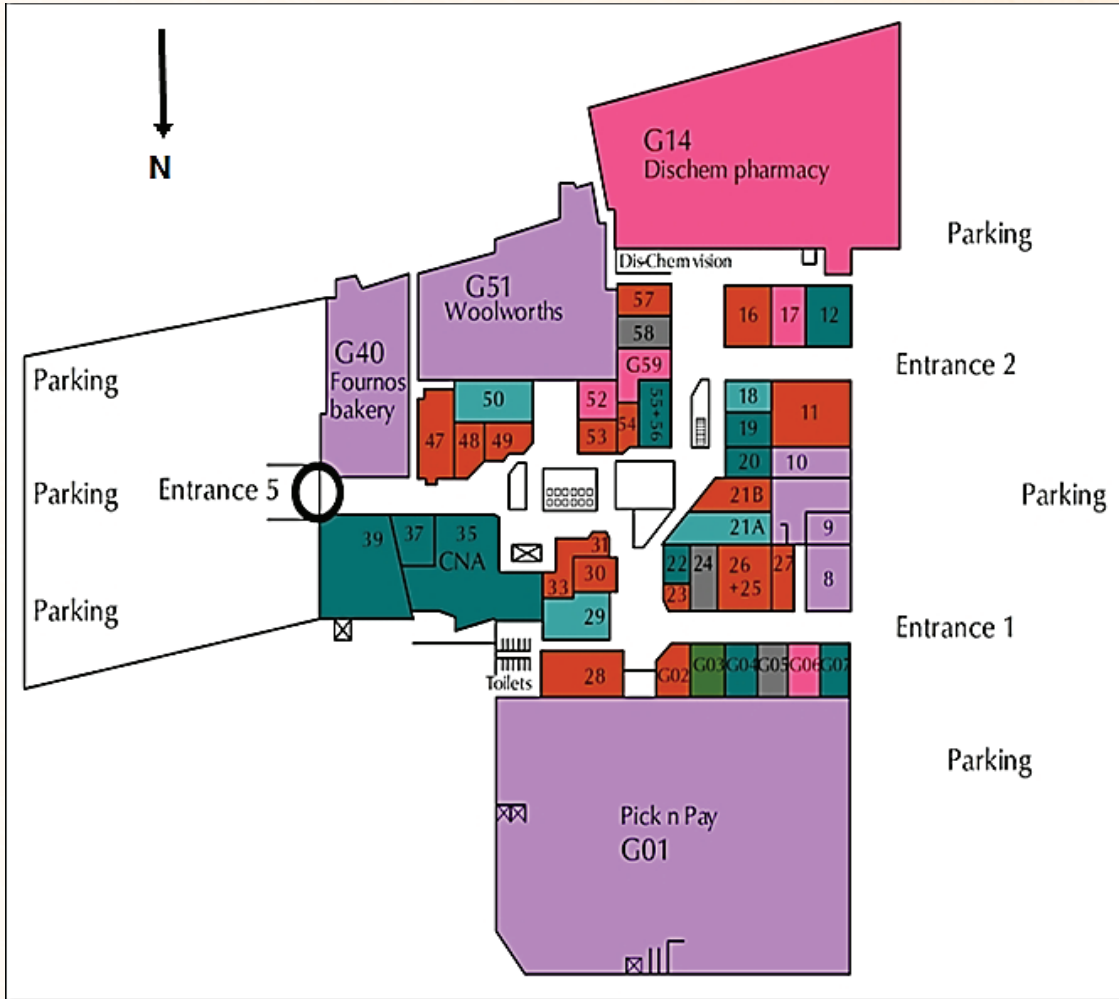

- 4.1 Name the biggest shop that you will pass first if you enter the Mall through Entrance 1. (2)
- 4.2 Name the entrance point(s) situated on the west side of the mall. (2)
- 4.3 What is the general position of shop G14 with reference to shop 35? (2)
- 4.4 You are a car guard in the parking area near Entrance 5. You assist a customer by providing directions to the toilet facilities. Give him directions to the toilets if he enters through Entrance 5. Include compass directions in your explanation. (5)



QUESTION 5

Study the strip chart below of the route from Gauteng to Namibia and answer the questions that follow.

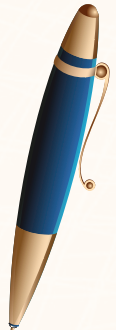
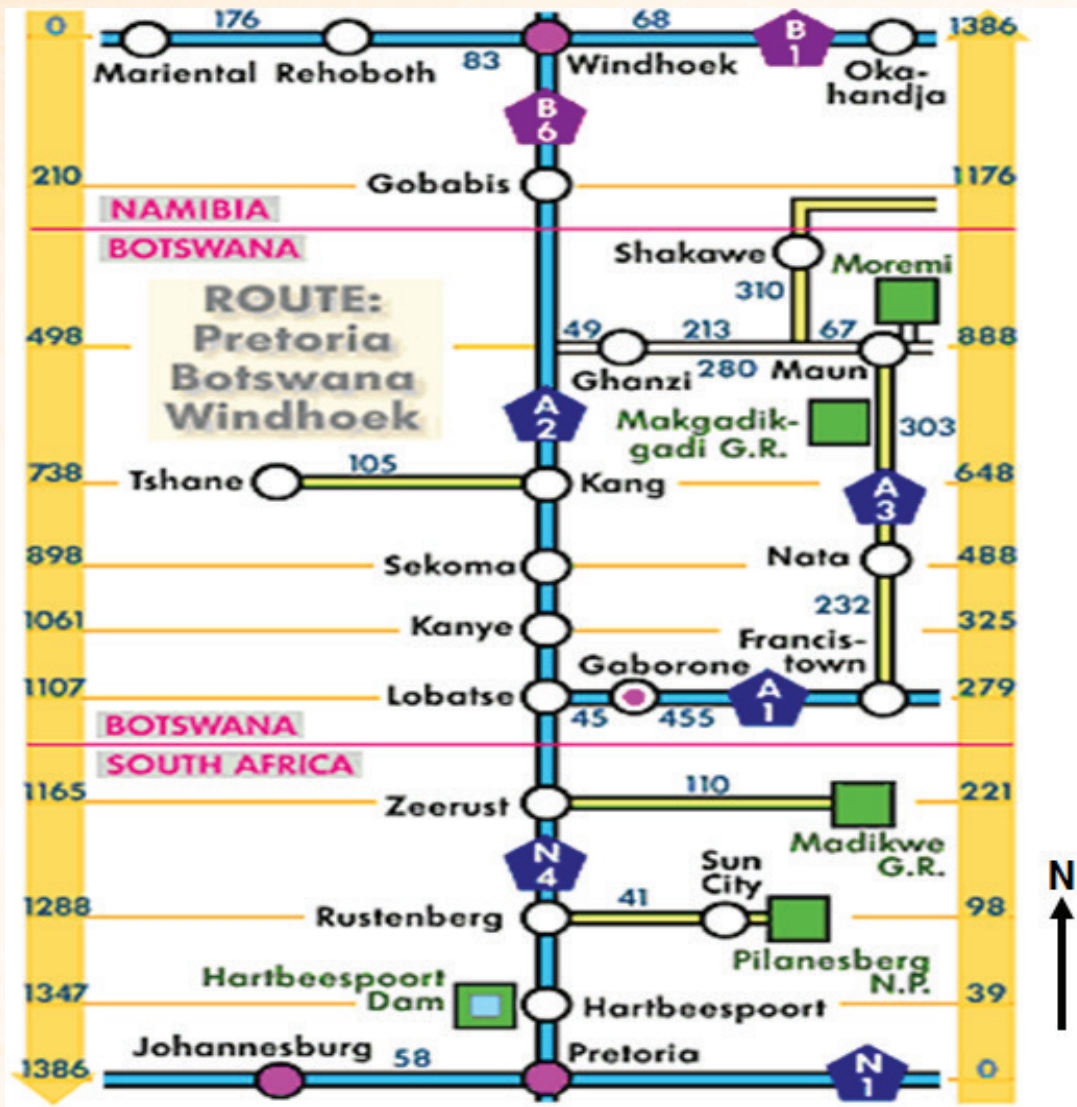

- 5.1 What is the direction of Okahandja relative to Johannesburg? (2)
- 5.2 James travelled from Gaborone, turning south at Lobatse via N4. At Zeerust, he turned left and travelled 110 km. What is his current destination? (2)
- 5.3 Describe the route in sequence; when one is travelling from Johannesburg to Sun City, by mentioning the national roads and towns where roads are changing/joining. (4)
- 5.4 What is the probability of passing a town that has a name that starts with the letter 'K' if you are travelling from Zeerust to Tshane? Give your answer as a percentage. (3)

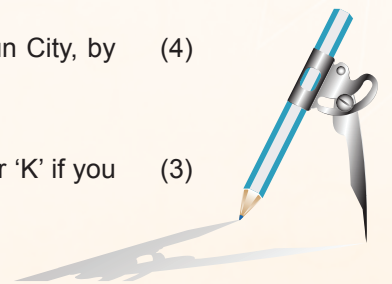

QUESTION 6

Study the map of the Johannesburg City Centre below, and answer the questions that follow.

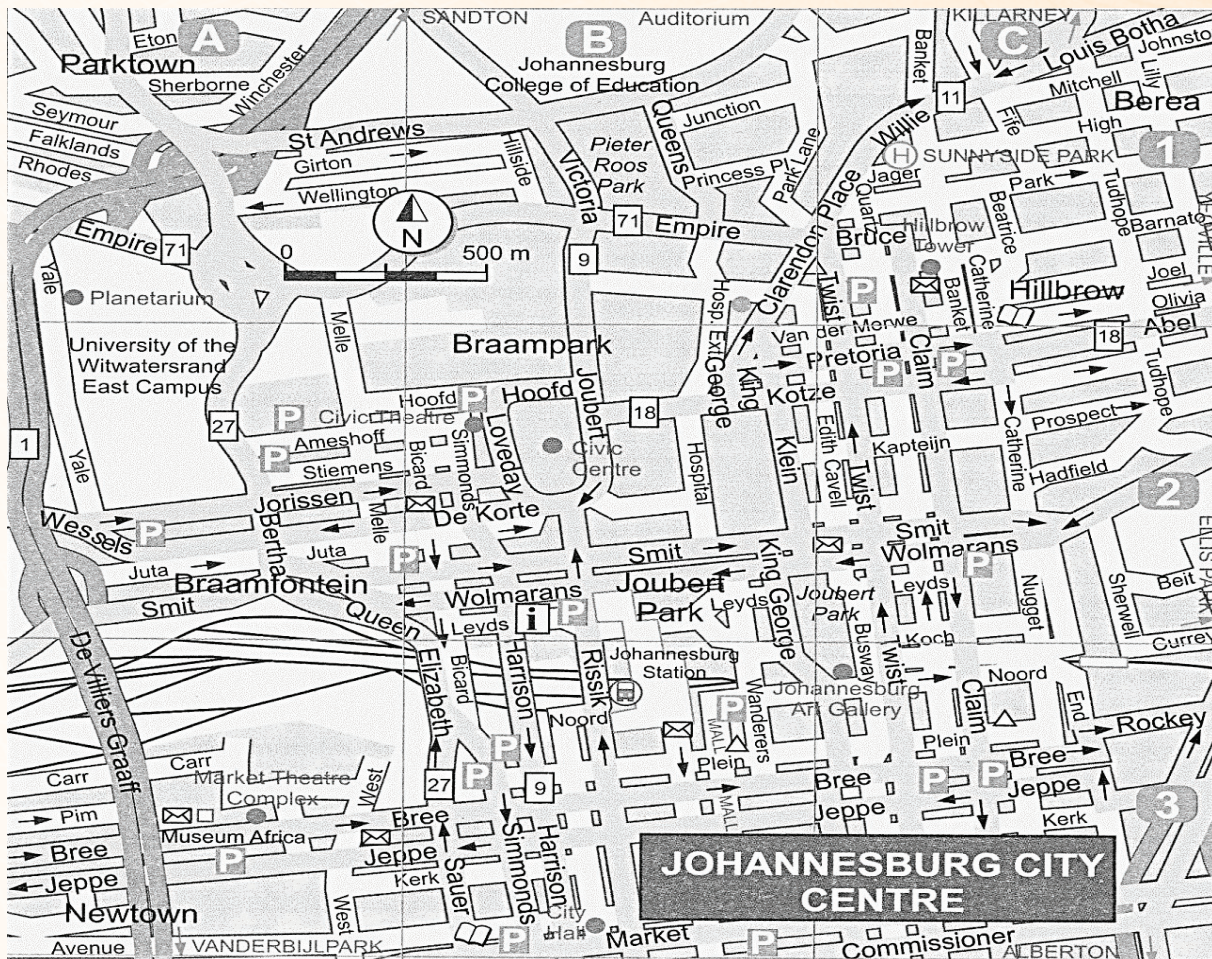

- 6.1 The traffic in Catherine Road (**Grid B2**) can only flow in one direction. What is the compass direction of the flow? (2)
 - 6.2 What do we call streets that only flow in one direction? (2)
 - 6.3 Name any street where the traffic can only flow in an easterly direction. (2)
 - 6.4 Give the grid reference of the Johannesburg College of Education. (2)
 - 6.5 Marcia wanted to visit the Johannesburg Art Gallery (**Grid C3**), but found herself at the City Hall (**Grid B3**). Give Marcia detailed directions on how to walk from the City Hall to the Johannesburg Art Gallery (3)
- Write the scale of the map as 1 : ... Show all calculations. (3)

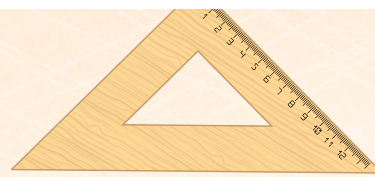

QUESTION 7

Study the map of Grahamstown in the diagram below and answer the questions that follow.

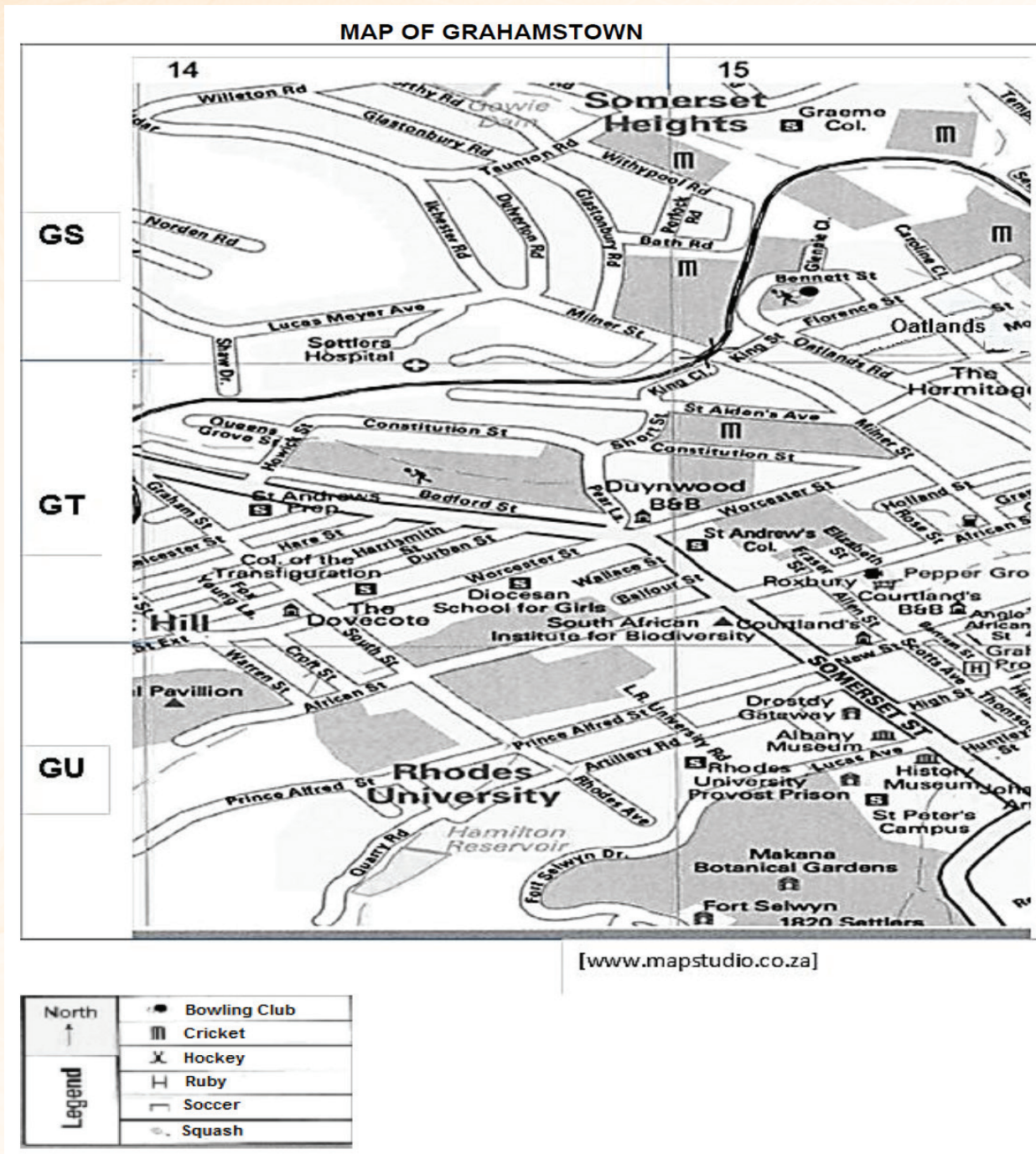

- 7.1 Give the grid reference for the Diocesan School for Girls. (2)
- 7.2 Identify the number of cricket fields found in this area of Grahamstown. (2)
- 7.3 Name the road that crosses Taunton Road. (2)
- 7.4 Identify the institution which cares for a collection of artefacts and other objects of scientific, artistic, cultural and historical importance by referring to grid reference GU15 South West of Graham Protea. (2)



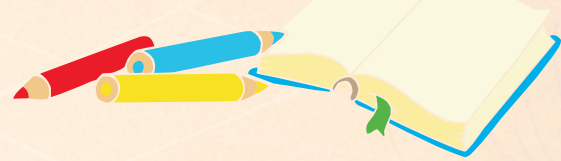
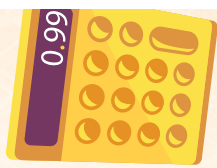

7.5 Give the general direction of Somerset Heights with reference to Oatlands. (2)

QUESTION 8

Below is a street map of East London in Eastern Cape. Use it to answer the questions below.



[Source: <http://www.sa-venues.com>]

- 8.1 Which national road will you use when travelling from Haven Hills to Mthatha? (2)
- 8.2 The distance between Milner Estate and Stirling is 8 cm on the map. Use the scale 1 : 50 000 to calculate the actual distance in km. (3)
- 8.3 Which suburb is between the N2 and the R102? (2)



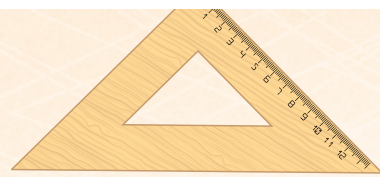

QUESTION 9

Below is a floor plan of an RDP house. Use it to answer the questions below.

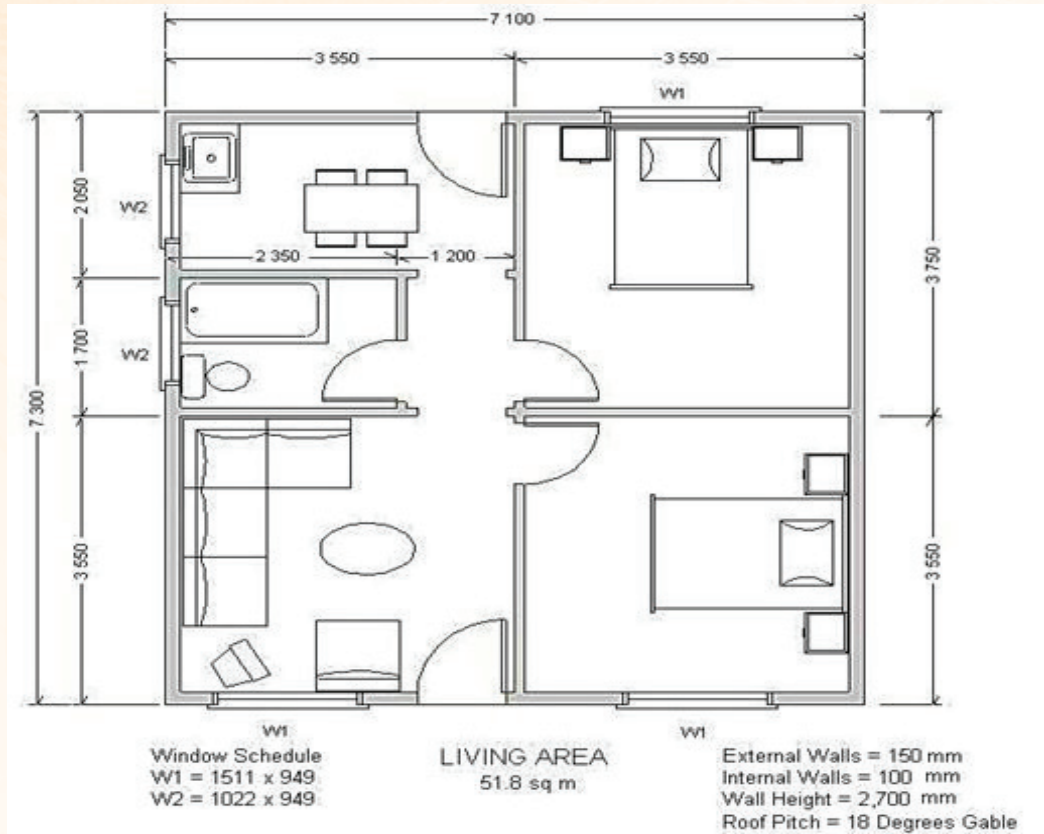

[Source: moladi.com/Lightweight-Construction-Method.htm]

- 9.1 How many windows are shown on the plan? (2)
- 9.2 How many doors are shown on the plan? (2)
- 9.3 What is the probability of finding a door that opens towards the left in the plan from outside? Give your answer as a decimal. (3)
- 9.4 If the outside wall of the bathroom measures 34 mm on plan, determine the scale of the RDP floor plan. (3)

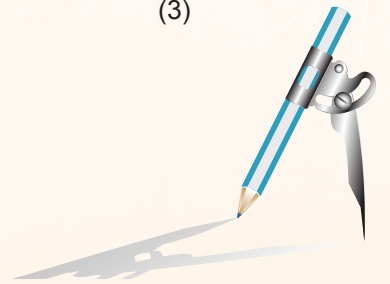

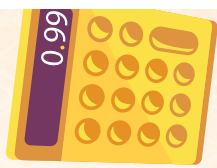

QUESTION 10

Kate lives in Mokopane in Limpopo and plans to visit her relatives in Volksrust, Mpumalanga. She used the map below to plan the trip.



[Source: Google Maps]

- 10.1 (a) Write down the name of the national road she can use to travel to Volksrust. (2)
- (b) Write down three possible major towns where Kate can stop on her journey to Volksrust. (3)
- 10.2 (a) Explain what the bar scale on the map indicates. (3)
- (b) Use the bar scale to determine the straight-line distance from Mokopane to Volksrust. (4)



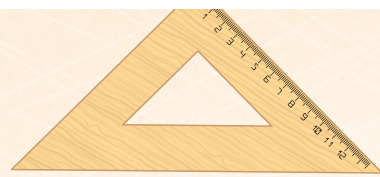

QUESTION 11

Study the street map below, then answer the questions that follow.

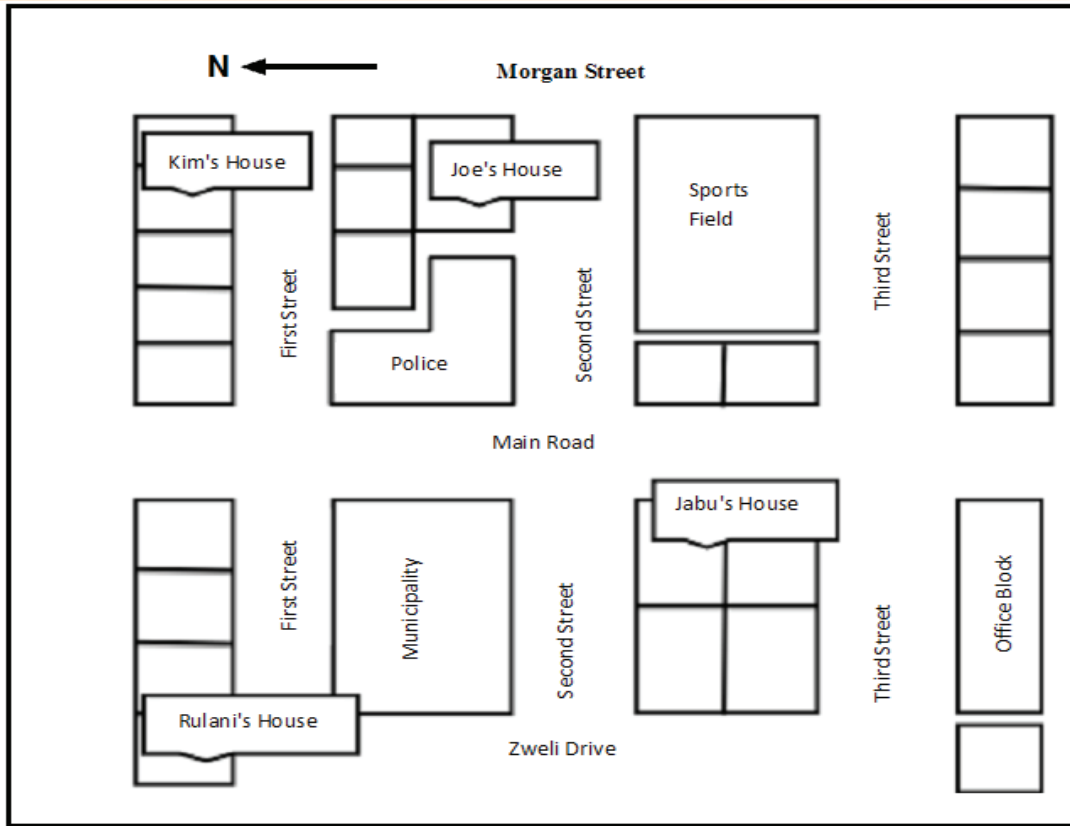

Kim, Joe, Jabu and Rulani work in the offices on Third Street.

- 11.1 Describe the shortest route that Kim can take to pick up Rulani and Joe on her way to work. (6)
- 11.2 Jabu walks to work. The distance she walks is 600 m; and on the map it is 40 mm. Use this information to determine the scale of the map. (3)
- 11.3 What is the general direction of the sports field relative to the Municipality? (2)

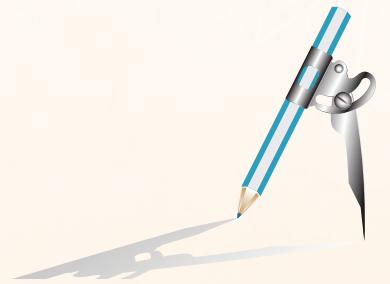

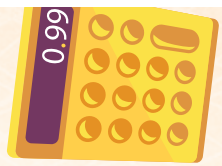

QUESTION 12

Maxwell moved to Candler Park neighbourhood in the US. Candler Park is a 55-acre city park located at 585 Candler Park Drive NE, in Atlanta, Georgia. The map of the neighbourhood is given below. Use the map to answer the questions that follow.

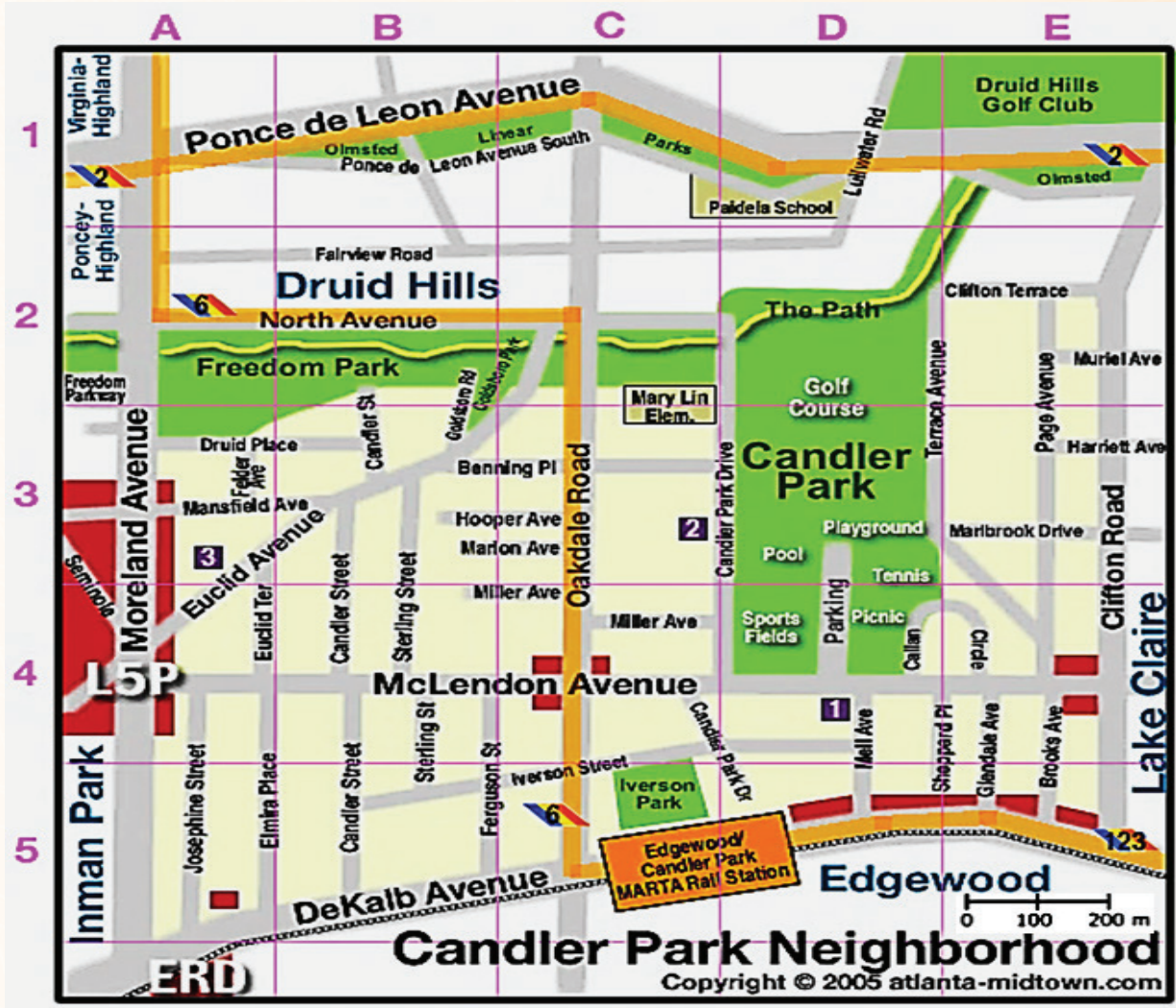
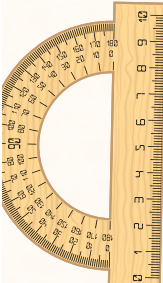

- 12.1 Give the grid reference for Iverson Park. (2)
- 12.2 The diagram distance from Josephine street to Candler street, using DeKalp Avenue, is 2 cm. Use the scale on the map to determine the actual distance. (3)
- 12.3 Maxwell stays at the corner of Josephine Street and DeKalb Avenue. Describe the route he can use to drive to Candler Park, if he decides to turn left from his gate. Assume that his gate is facing DeKalb Avenue. (4)

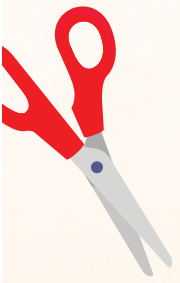



QUESTION 13

This is a map showing a section of the London Underground tube (train) system. Refer to this when answering the questions below.

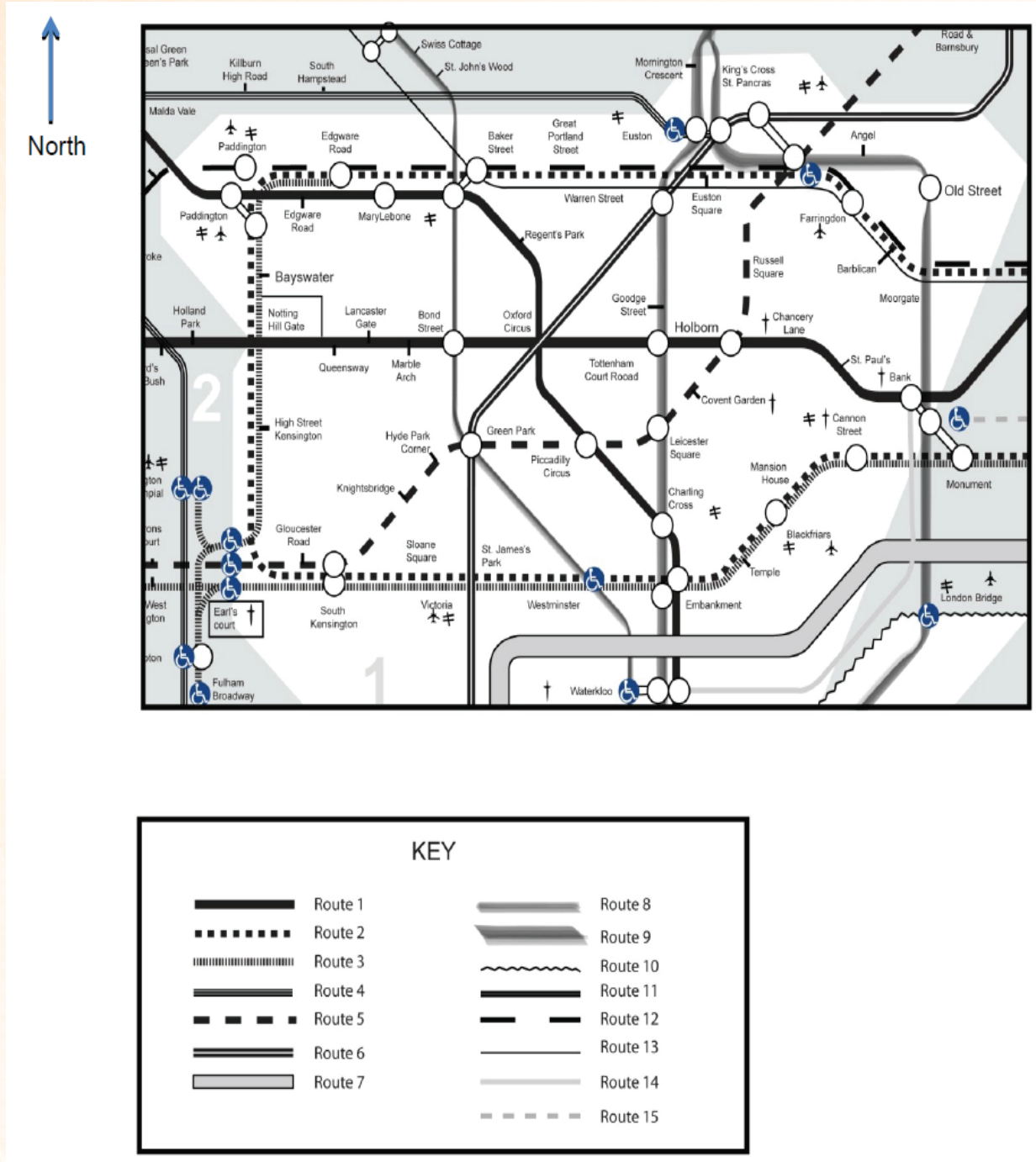

13.1 If you got onto the tube at Oxford Circus (Route 1), what direction would you travel to get to:
(a) Notting Hill Gate

(2)





(b) Gloucester Road (2)

(c) Warren Street (2)

13.2 The scale of the map of London is 1 : 50 000.

(a) It is given that the distance between Holland Park and Tottenham Court road is 53 mm. (3)
Use the scale to calculate how far is this in real life? Give your answer in millimetres.

(b) Use the answer to (a) to calculate the distance in kilometres. (3)

3.2.2 Possible answers to the questions for the section on Maps, plans and representation of the physical world

QUESTION 1 (ANSWERS)

1.1 4,2 : ?
1 : 13 000
 $4,5 \div 1 = 4,5$
 $4,5 \times 13\ 000 = 58\ 500\checkmark$
 $58\ 500 \div 100\ 000\checkmark = 0,59\ \text{km}\checkmark$

Always work with the scale provided and ensure that you convert, as requested in the question. The skill needed is basic cross multiplication.

1.2.1 5,5 : ?
1 : 80
 $5,5 \times 80\checkmark = 440\ \text{cm}\checkmark$ (Refer to 1.1 above)

1.2.2 North East / NE $\checkmark\checkmark$

An arrow indicating North or compass is given which must be used as reference to determine the correct position/direction

1.2.3 4,5 cm : 225 cm
 $\checkmark = 50\checkmark$
Scale is 1 : 50 \checkmark

1.2.4 ? : 520 cm
1 : 80
 $\checkmark = 6,5\ \text{cm}\checkmark$

QUESTION 2 (ANSWERS)

2.1 Five telephone outlets $\checkmark\checkmark$ () Fully drawn floor plans have a legend/key, i.e. symbols representing the various items in the house. E.g. the symbol for the telephone appears in the Boardroom and the four office spaces.

2.2 $2\checkmark : 6\checkmark = 1 : 3\checkmark$

Ratio is used to compare values. The number of the outside door to the number of the outside doors in that order

2.3 1 unit on the plan equals 200 units in real life. $\checkmark\checkmark$

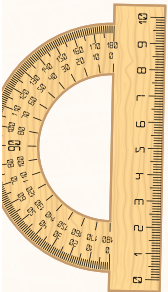

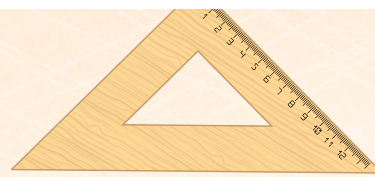

2.4	Length : 11,70 : ? 1 : 200 $11,70 \times 200 \checkmark = 2\,340 \text{ cm} \checkmark$ Width : $10,40 \times 200 = 2\,008 \text{ cm} \checkmark$
2.5	$P = 0 \checkmark \checkmark$

QUESTION 3 (ANSWERS)

3.1	Parking area $2 \checkmark \checkmark$
3.2	Merry-go-round $\checkmark \checkmark$
3.3	Open soccer and volleyball field $\checkmark \checkmark$
3.4	$15 \text{ m} = 1\,500 \text{ cm}$ $\checkmark = 250 \checkmark$ Scale: $1 : 250 \checkmark$

QUESTION 4 (ANSWERS)

4.1	Pick 'n Pay $\checkmark \checkmark$
4.2	Entrances 1 and 2 $\checkmark \checkmark$
4.3	South West / SW $\checkmark \checkmark$
4.4	Enter through Entrance 5 and move westwards \checkmark ; take a slight right, proceeding in a north-westerly direction \checkmark . Take a right turn North, just after shop 31; proceed \checkmark and turn right just after shop 29 \checkmark . Move to the west between shops 29 and 28. toilets will be in front. \checkmark

QUESTION 5 (ANSWERS)

5.1	North East / NE $\checkmark \checkmark$
5.2	Madikwe Game Reserve $\checkmark \checkmark$
5.3	Travel via the N1 to Pretoria \checkmark ; turn north onto the N4; pass Hartebeespoort \checkmark ; turn right at Rustenburg \checkmark ; Sun City will be 41 km ahead. \checkmark (Refer to 4.4 above.)
5.4	$P = = = 0,5 = 50\% \checkmark$

QUESTION 6 (ANSWERS)

6.1	South $\checkmark \checkmark$
6.2	One-way streets $\checkmark \checkmark$
6.3	Girton $\checkmark \checkmark$ / Park / Jorrison / Juta / Breë / Smith / Prospect / Olivia / Park (Any 1)
6.4	B1 $\checkmark \checkmark$
6.5	Up Harrison Street \checkmark – Right into Breë Street \checkmark - Left into King George Street \checkmark (accept any logical directions) (Refer to 4.4 above.)



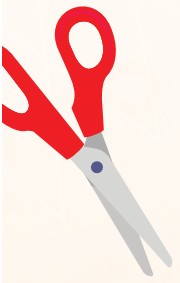
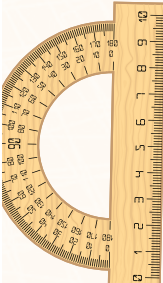
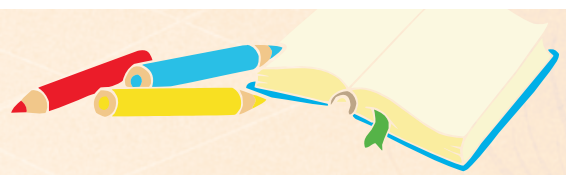
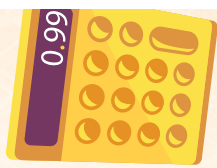

6.6	Scale: 25 mm = 500 m 1 mm = 20 m✓ 1 mm = 20 000 mm✓ Scale is 1: 20 000✓
-----	---

QUESTION 7 (ANSWERS)

7.1	GT14 ✓✓
7.2	5 ✓✓
7.3	Glastonbury Road ✓✓
7.4	Albany Museum ✓✓
7.5	North West ✓✓

QUESTION 8 (ANSWERS)

8.3	Aquarium ✓✓
8.2	N2 ✓✓
8.3	50 000 x 8 ✓ = 400 000 cm/100 000 ✓ = 4 km✓
8.4	Summerpride ✓✓

QUESTION 9 (ANSWERS)

9.1	Five (5) ✓✓
9.2	Five (5) ✓✓
9.3	= 0,6✓
9.4	34 : 1700 = 50✓ Scale is 1 : 50✓

QUESTION 10 (ANSWERS)

10.1 (a)	N11 ✓✓
10.1 (b)	Groblersdal✓, Middelburg✓ and Ermelo✓
10.2 (a)	The bar scale measures 2 cm✓, hence 2cm on the map represents 100 km in real life. ✓✓
10.2 (b)	Straight distance: 8 cm✓ Scale is 2 cm : 100 km✓ ✓ = 400 km✓

QUESTION 11 (ANSWERS)



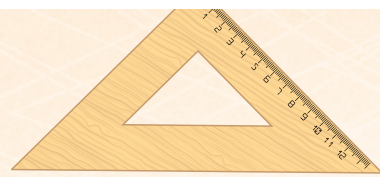

11.1	Turn left onto First Street then right at Morgan Street ✓. Joe's house is the second house on the right. ✓ Turn right onto Second Street then turn right onto Main road and then left onto First Street. ✓ Rulani's house is the last house on the right. ✓ From Rulani's house, turn right onto Zweli Drive and carry on until Third Street ✓. At Third Street, turn left. The office block is on the right. ✓
11.2	40 mm : 600 m = 15 000 ✓ 1:15 000 ✓
11.3	South East / SE ✓✓
QUESTION 12 (ANSWERS)	
12.1	C5
12.2	Scale 0,9 cm = 100 m = 222,22 m
12.3	Drive up Josephine street ✓, turn right on McLendon Avenue ✓ and pass Oakdale Road ✓ and park in the Parking area at Candler Park. ✓
13.1 (a)	West ✓✓
13.1 (b)	South-west ✓
13.1 (c)	North-east ✓✓
13.2	Travel North-East from South Kensington on the Piccadilly line ✓ until you get to Green Park, where you change to the grey line ✓ and then travel North to Bond Street. ✓
13.3	Four times ✓✓
13.4 (a)	1 ✓: 150 000 ✓ 53 mm : 7 950 000 mm ✓
13.4 (b)	1 m = 100 cm 1 km = 1000m = 1000 000mm ✓ 7 950 000 ÷ 1 000 000 ✓ = 7,95 km ✓



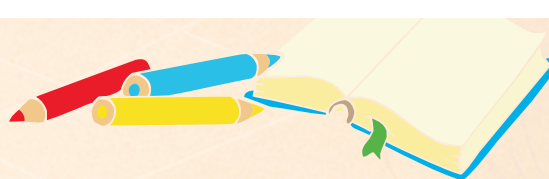
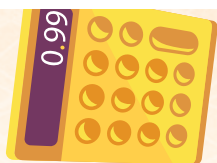

3.3 MEASUREMENT

Make sure you are able to:

- Calculate and estimate values using basic operations that involve length and distance and where each of the required dimensions is readily available.
- Understand and use formulae such as the following, where the dimensions and formulae are readily available: perimeters and areas of polygons, volume of right prisms, right circular cylinders, surface areas of right prisms and right circular cylinders.
- Understand and use appropriate vocabulary, such as: equation, formulae, Cartesian plane, area, surface area, perimeter, radius, diameter, length, breadth, height, base, circumference, volume, circle, cylinder, polygons, right prisms, triangular, rectangular and square.
- Read information directly from a table and use some given information and simple operations to complete a table of values.
- Measure values that involve length, distance, weight and time, using appropriate measuring instruments that are sensitive to levels of accuracy in a familiar context.
- Describe the relationship between input and output values in a table of data concerning space, shape and measurement.
- Convert units of measurement between different scales and systems using conversion tables provided.
- Converting to a smaller unit of length, time, weight, etc.
- Converting to a bigger unit of length, time, weight, etc.
- Converting units of area.
- Converting units of volume.

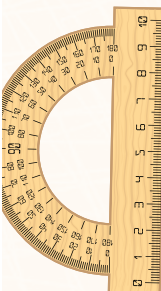

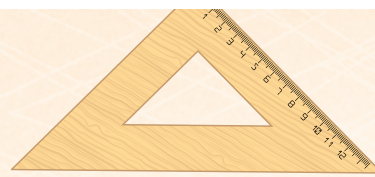

Glossary for Measurement

TERM / CONCEPT	DEFINITION/ EXPLANATION
Analogue	An analogue measuring instrument displays values by the position of a needle or hands on a dial, e.g. an analogue clock or scale.
Approximating	To round a value to the nearest convenient value.
Approximation	A stated value of a number that is close to the true value of that number.
Area	The amount of two-dimensional (2-D) space occupied by a 2-D shape. The area of a shape is the size of its surface. It is measured in square units.
2-D drawings	A diagram or picture that has length and width only.
2-dimensional plans	A plan or design that has length and width only, but possibly represents 3-dimensional objects.
3-dimensional models	A dimensional construction of a real-life object. It is a solid, and it has length, breadth/ width and height.
Body mass index (BMI)	A number calculated from an adult's weight and height, expressed in units of kg/m^2
Bearing	Direction.
Bisect	To cut or divide into two identical parts.
Calculate	Work out.
Capacity	The amount of space available to hold something. OR A measure of the volume a hollow object can hold - usually measured in litres.
Circle	A closed curve that is everywhere the same distance from the fixed middle point.
Circumference	Distance around a circle / the perimeter of a circle.
Context	A real-life situation.
Conversion	A change from one system /unit to another.
Conversion factor	Values used to convert/ change quantities from one measuring system to another.
Cylinder	A 3-dimensional object with congruent parallel circles and bases that are joined by a curved surface.
Degrees Celsius	Units used to measure temperature in most countries.
Diameter	A straight line passing through the centre of a circle and touching the circle at both ends, thus dividing the circle into two equal halves.
Digital	A digital measuring instrument that displays values in numbers or digits, e.g. a digital clock or scale.
Distance	How far it is from one place to another, e.g. from one town to another. It is usually measured in kilometres and does not have to be measured in a straight line.
Elapsed time	Time that has passed since the start of an event.
Estimate	The approximation, prediction or projection of a quantity based on experience or information available at the time.
Express	Write.
Grid	A network of parallel and perpendicular lines that form rectangles.
Growth charts	Graphs consisting of a series of percentile curves that show the distribution of the growth measurements of children.
Hexagon	A polygon with six sides.
Horizontal	The x-axis, i.e. across the page in a left-right orientation; lying down.

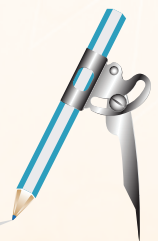

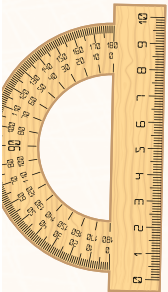
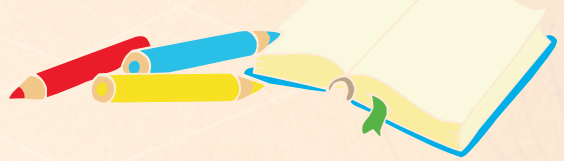
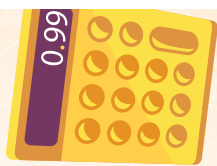

Hypotenuse	The side of a right-angled triangle that is opposite the right angle.
Imperial System	A system of measurement using inches, pounds, feet, gallons and miles.
Indigenous measurement	Traditional informal methods of measuring used by our ancestors.
Investigate	Examine; look into; study.
Length	The measurement between two points, in a straight line, e.g. the length of a room.
Literacy	The ability to read and write.
Mass	An indication of how heavy an object is. (Also known as weight.)
Measure	Using an instrument to determine size, weight, etc.
Measuring	Determining the value of a quantity directly, e.g. reading the length of an object from a ruler or the mass of an object from a scale.
Metric System	A system of measurement that uses metres, litres, kilograms, etc.
Modify	Change; adapt.
Perimeter	The total distance around the boundary or edge that outlines a specific shape.
Perpendicular	Two lines that cross each other at right angles.
Pi	The value obtained when dividing the circumference of a circle by its diameter.
Polygon	A two-dimensional shape enclosed by three or more straight sides.
Prism	A three-dimensional object, such as a cylinder with two identical faces at opposite ends. There are triangular, rectangular and circular prisms.
Quadrilateral	A polygon with four sides.
Radius	The distance from the center of the circle to any point on the circumference of the circle-
Regions	Specific areas.-
Result	Something that follows on from an action-
Revolution	360° turn
Rotation	A transformation under which a point or shape is turned around a fixed point-.
Rounding off	To decide to cut off a number at a certain digit to make it simpler but keeping its value close to what it was.
Rule-of-thumb	A handy, generally accepted rule.
Scale	An instrument that is used to measure the mass (weight) of an object.
Spread rate	The conversion ratio for converting from area to liquid volume.
Substitution	To replace a variable by a specific value.
Surface area	The area of all the faces/ surfaces of an object added together.
Tide table	A timetable that shows the time of the day and night at which the level of the sea reaches high and low tide.
Travel timetable	A document showing transport arrival and departure times and destinations.
Thermometer	An instrument used to measure temperature.
Unit of measurement	A standard amount of a physical quantity.
Undefined	Cannot be defined or written down; division by zero.
Vertical	The y axis; i.e. down a page in a top-bottom orientation; standing up.
Vertex	The point or corner at which the edges of a polygon meet.
Volume	The amount of 3-D space occupied by an object. It is measured in cubic units.





3.3.1 Exemplar Questions for Measurement

QUESTION 1

One of the oldest professional surfing gatherings in the world - the Mr Price Pro - has earned legendary status in the world of surfing, since it started in 1969. At that stage, it was known as the Gunston 500. Shaun Thomson, a Durbanite, won the competition every year from 1973 to 1978.



[Source: <http://www.mrpricepro.com/Default.aspx>]

The banner above has been designed by an American company.

It is 0,2 miles long and 27 feet wide.

1.1 Calculate the dimensions of the banner in metres.

(4)

1 mile = 1 609 m and 1 foot = 0,305 m

1.2 Calculate the area (in m^2) of a smaller Mr Price Pro banner, if the measurements are 6,3 m by 2,4 m.

(2)

Use the formula: **Area of banner = length \times width**

1.3 The banner - with a length of 6,3 m and a width of 2,4 m - has to be hemmed with ribbon. The price of the ribbon is R4,99 per 50 cm.

1.3.1 Calculate the price of one metre of ribbon.

(2)

1.3.2 Calculate the perimeter of the banner. Provide the answer in metres.

(2)

Perimeter = $2 \times$ length + $2 \times$ width



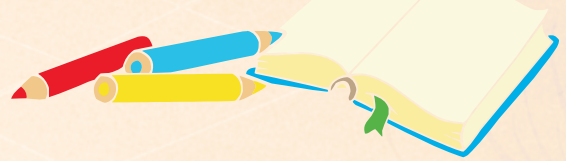
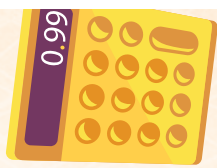

QUESTION 2

Thembinkosi's last successful project was digging a cylindrical hole to secure a trampoline for his children.

The dimensions of the hole he dug

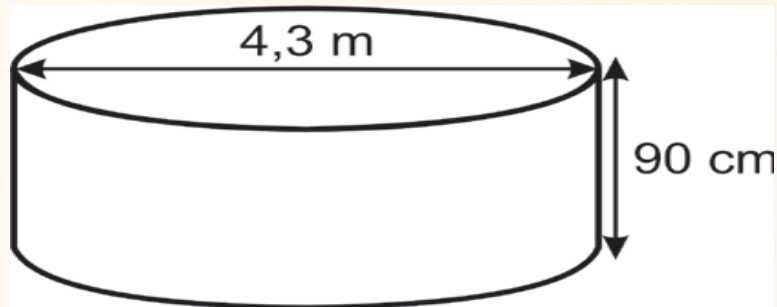

Although Thembinkosi has reused some of the excavated (dug up) sand, he still has two-thirds of the sand left over. A company is prepared to collect the sand free of charge, provided there is more than 5 m^3 .

- 2.1 Calculate the area of the base of the hole in square metres, rounded off to 2 decimal places. (3)

Area = πr^2 where r = radius and $r = 3,14$

- 2.2 Determine, showing all calculations, whether there is enough sand for the company to come and collect it free of charge. (5)

Volume = Area of base \times height

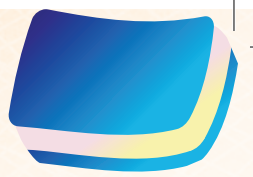
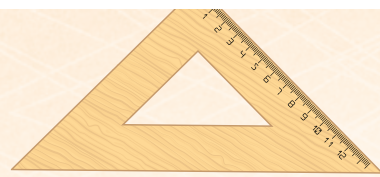

QUESTION 3

Water is scarce in South Africa. The annual average rain fall is 446 mm. According to Statistics South Africa (www.statssa.gov.za), 88,6% of the South African population has access to drinking water.

The measurements of a water tank are given in metres. The water tank's radius is 14 m and its height is 10 m.



- 3.1 Explain the difference between diameter and radius. (2)
- 3.2 Determine the diameter of the water tank. (2)
- 3.3 The lid of the water tank must be painted on the outside, in order for it to be clearly visible. (2)

Calculate the area of the lid (in m^2), if it has a radius of 14 m.

Use the formula: **Area** = $\pi \times (\text{radius})^2$, where $\pi = 3,14$

- 3.4 A one-litre tin of paint covers an area of 15 m^2 . Calculate the area that can be covered with 17 litres of paint. (2)
- 3.5 The inside of the tank must be sealed with waterproof paint. The lid does not get waterproofed on the inside. Calculate the interior surface area (in m^2) using the following formula: (3)

Inside area = $(2 \times \pi \times r \times h) + (\pi \times r^2)$, where $\pi = 3,14$, r = radius

and h = height / depth of the water tank

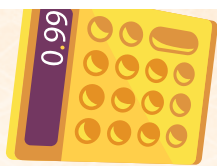

3.6 Calculate the volume of water (in litres) that can be contained by the water tank. (3)

Use the formula: **Volume = $\pi \times r^2 \times h$**

$\pi = 3,14$

r = radius

h = height / depth of the water tank
and $1 \text{ m}^3 = 1\,000$ litres

QUESTION 4

4.1 Sinethemba makes and sells rectangular tea towels (with dimensions $30 \text{ cm} \times 45 \text{ cm}$) and square dish cloths (with a length of 30 cm) at a local flea market, as shown in the photographs below.

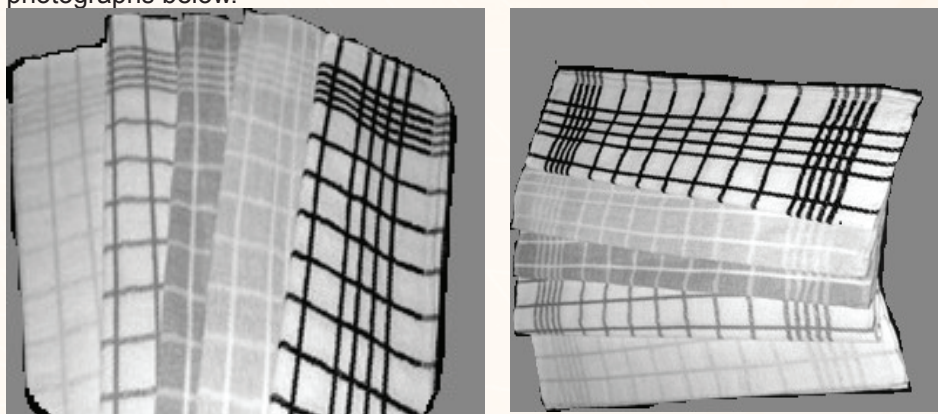

4.1 Calculate the area of the material needed to make ONE tea towel. (2)

You should use the formula:

Area of a rectangle = length \times breadth

4.2 Sinethemba wants to add a decorative border to some of the tea towels. (3)

Calculate the perimeter of a tea towel.

You should use the formula:

Perimeter of a rectangle = $2(\text{length} + \text{breadth})$

QUESTION 5

Mrs Mokoena is hosting a stokvel meeting and she plans on serving tea to the members during the meeting. There are twenty other members and Mrs Mokoena in the stokvel. Study the ingredients below and answer the questions that follow.



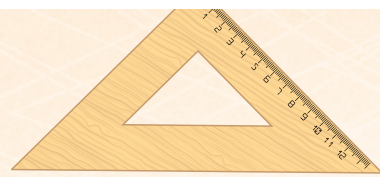

Ingredients for making tea in a three-litre teapot

3 litres of boiling water
10 teabags
15 table-spoons of sugar
*Boiling water is at 212° F
*A 3-litre teapot serves 10 people (1 cup per person)
*1 tablespoon = 2 tea-spoons

- 5.1 How many members does this stokvel have? (2)
- 5.2 How many millilitres of water are needed for one teapot? (2)
- 5.3 If one teabag weighs forty grams, how many kilograms of teabags will be in one teapot? (3)

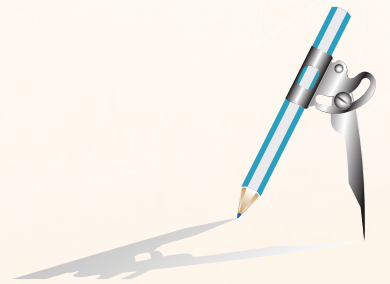

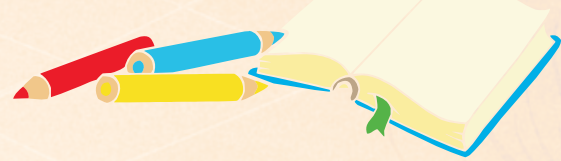
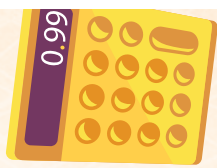
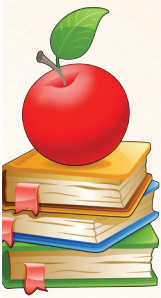

5.4 How many teaspoons of sugar will be needed for one cup of tea? (3)

5.5 How many tablespoons of sugar will be needed to make enough tea for all the members? Note: tea can only be made using the teapot. (3)

5.6 Give the boiling point of water in degrees celcius. (2)

Use the formula: $^{\circ}\text{C} = (^{\circ}\text{F} - 32) \div 1.8$

5.7 Mrs Mokoena boiled water for 27 minutes on the stove, due to a problem with her electrical kettle; she started making tea at the time shown on the watch. (2)



At what time did she start to boil water?

5.8 The day that they will be having a stokvel meeting is also the birthday of one of the stokvel members. Mrs Mokeona plans to give her muffins as her gift. She will put them in a gift container that accommodates 9 muffins, as shown in the diagram below.

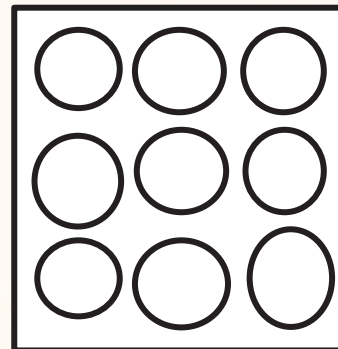

Each muffin has a diameter of 4 cm and a height of 5.5 cm The container has a space allowance of 1.5 cm around and a height allowance of 1.5 cm on top.



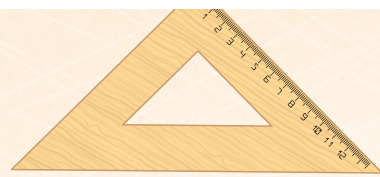

5.8.1 Find the length, width and height of the container. (3)

5.8.2 Calculate the surface area of the container. (3)

Use the formula $SA=2(\ell \times b + \ell \times h + b \times h)$

5.8.3 If it costs 4 cents per square centimetre (VAT excl.) to make the container, calculate the cost of making this cake container (VAT incl.) (5)

QUESTION 6

Mrs Mpanza runs a small business from her home. She buys different types of laundry baskets and covers the inside of the baskets with fabric. Then she resells them.

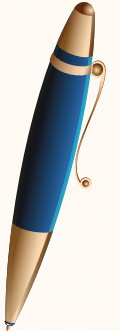

The dimensions are as follows:

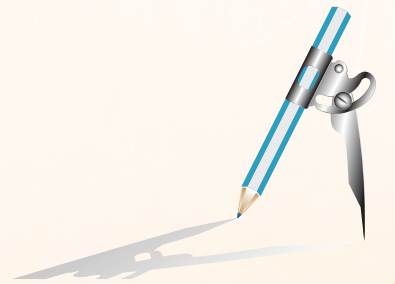
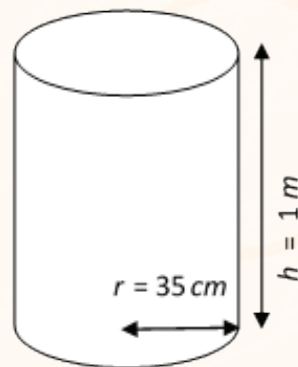
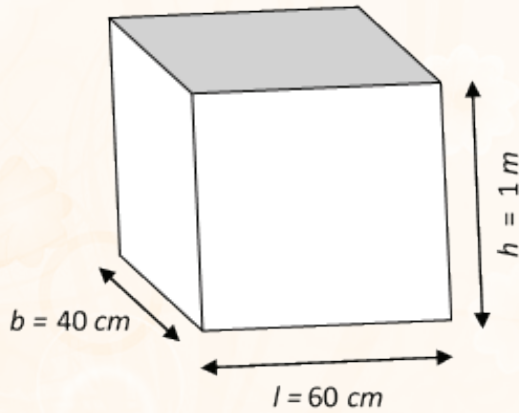

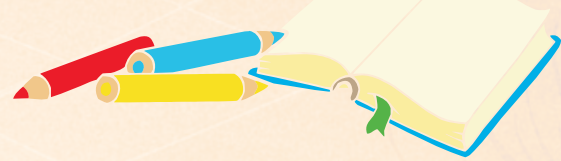
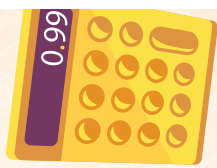

- 6.1 How much fabric will Mrs Mpanza need (in m^2) to cover the sides and base on the inside (but not the lid) of a rectangular laundry basket? (4)

Use the following formulae: Surface area = $(l \times b) + 2(l \times h) + 2(b \times h)$

- 6.2 Calculate the amount of fabric needed to cover the base and sides of the inside of the cylindrical laundry basket. Round off your answer to the nearest m^2 . (5)

Use the formula: Surface area = $(\pi \times r^2) + (2 \times \pi \times r \times h)$, use $\pi = 3,14$

- 6.3 Mrs Mpanza also sews round tablecloths for tables with a diameter of 2,5 m. These tablecloths overlap the table by 20 cm.

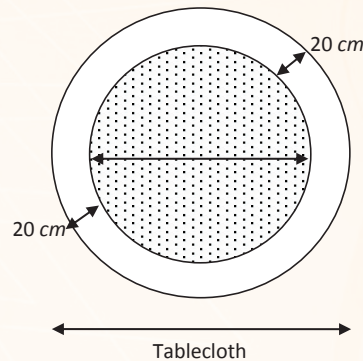

- 6.3.1 Mrs Mpanza adds a lace border to each tablecloth. If lace is only sold in full metres, how much lace will Mrs Mpanza need to buy, to sew it around the outside edge of the tablecloth? (7)

Use the following formulae:

Diameter of the tablecloth = diameter of table + $(2 \times 20 \text{ cm})$

Circumference of the tablecloth = $2 \times \text{radius}$ (use $\pi = 3,14$)

- 6.3.2 She received an order for 10 tablecloths. If the price of the lace is R12 per metre, calculate the cost of all the lace needed. (2)
- 6.4 Mrs Mpanza's intended profit margin is 25%.
- 6.4.1 If her operating cost per table cloth is R135, what should the selling price be per tablecloth? (2)
- 6.4.2 When a client orders 10 or more tablecloths, Mrs Mpanza gives a discount of 5%. Calculate the amount due for 10 tablecloths (4)

QUESTION 7

Mr Rampedi is working as an intern at Cover company in Durban. The company designs boxes and other containers for dairy products. He is required to work on a design for an infant juice carton, as shown in the diagram.

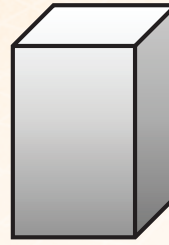

Picture of the dairy juice product containers.

The dimensions of the brick juice carton are: length = 5cm; breadth = 0.05m; height = 10cm.

Note: the dimensions of the base are the same as the dimensions of the top (lid).

Where: **V = length x breadth x height; Area = length x breadth.**

7.1 Determine the volume of each juice carton in cm^3 . (2)

Use the formula

7.2 Determine how much cardboard (the surface area) is needed to make one juice carton in cm^2 . NOTE: (5)

7.3 How many litres of juice can each carton fill? (3)

Hint: **1mL = 1cm³**

7.4 Calculate the cost to fill 100 cartons with juice, if juice costs R600 per kilolitre? Assume that you can buy exactly as much juice as is needed (For example, you don't have to purchase a whole kiloliter if you only need 10 litres.) (4)

7.5 A dairy truck has a cylindrical tank that is used to transport juice. The tank has a radius of 1.5 m and a length of 3 m.



7.5.1 Calculate the volume of the tanker using the formula:, where r is the radius and h is the height (in this case, length). Use the formula to calculate the capacity of the tank in litres. Note: **1m³ = 1kl = 1000l** (5)

7.5.2 Determine how many juice cartons can be filled from one tanker truck? (2)

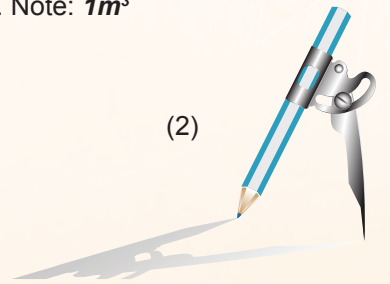

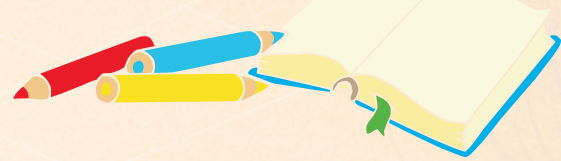
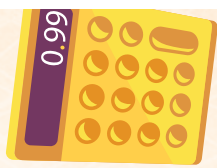

3.3.2 Possible Solutions for Measurement

QUESTION 1

Length

1.1 $= 0,2 \text{ miles} \times 1\,609 \text{ m} \checkmark$

$= 321,8 \text{ m} \checkmark$

Width

$27 \text{ feet} \times 0,305 \text{ m} \checkmark$

$= 8,235$

$= 8,24 \text{ m} \checkmark$

Area = length \times width

$= 6,3 \text{ m} \times 2,4 \text{ m} \checkmark$

1.2

$= 15,12 \text{ m}^2 \checkmark$

1.3.1

$4,99 \times 2 \checkmark$

$= R9,98 \checkmark$ for 1 metre

1.3.2

Perimeter = $2 \times$ length + $2 \times$ width

$= 2 \times 6,3 + 2 \times 2,4 \checkmark$

$= 12,6 + 4,8$

$= 17,4 \text{ m} \checkmark$

The dimensions of the banner are LENGTH and WIDTH - and in this case they are not given in metres. The first step that you need to do is to convert and it is important to know when to multiply. using the given information

It is important to copy the formula as it is given, to substitute carefully to avoid mistakes, and to make sure that units are always squared.

To determine the perimeter, you add all sides and the units thereof are similar to that of the length.

QUESTION 2

Radius = $\frac{4,3}{2} = 2,15 \checkmark$

2.1

Area = $\pi \times$ (radius)²

$= 3,14 \times 2,15^2 \checkmark$

$= 14,51 \text{ m}^2 \checkmark$

It is very important to know the difference between diameter and radius, because either radius or diameter can be given.

2.2

$90 \text{ cm} = 0,9 \text{ m} \checkmark$

Volume = $14,51 \times 0,9 \checkmark$

$= 13,06 \text{ m}^3 \checkmark$

$\frac{2}{3} \times 13,06$

$= 8,71 \text{ m}^3 \checkmark$

Two-thirds is greater than 5 m^3 , therefore collection will be free of charge.

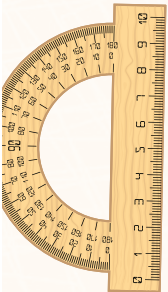

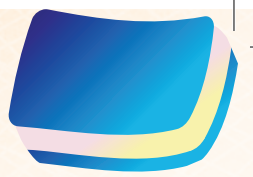
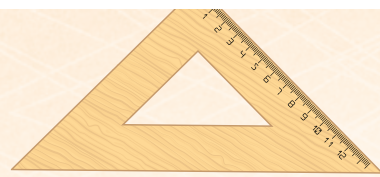

QUESTION 3

3.1 Radius is half the diameter. ✓✓

3.2 28 m ✓✓

3.3 Area

$$= \pi \times (\text{radius})^2$$

$$= 3,14 \times 14^2 \checkmark$$

$$= 615,44 \checkmark$$

3.4 $17 \times 15 \checkmark$

$$= 255 \checkmark \text{ m}^2$$

3.5 Interior surface area

$$= (2 \times \pi \times r \times h) + (\pi \times r^2)$$

$$= (2 \times 3,14 \times 14 \times 10) + (3,14 \times (14))^2 \checkmark$$

$$= 879,2 + 615,44 \checkmark$$

$$= 1\,494,64 \checkmark \text{ m}^2$$

Use the value of π given in the question.

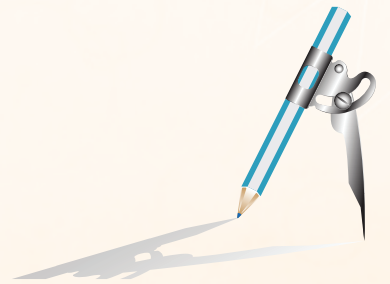

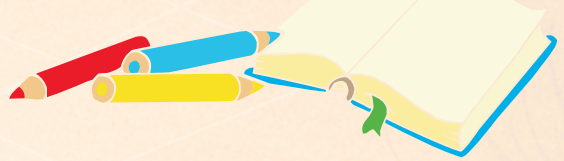
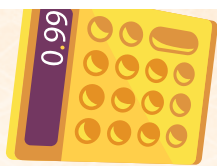

3.6

$$\text{Volume} = \pi \times r^2 \times h$$

$$= 3,14 \times (14)^2 \times (10) \checkmark$$

$$= 6\,154,4 \text{ m}^3 \checkmark$$

$$1 \text{ m}^3 = 1000 \text{ litres}$$

$$= 6\,154\,400 \text{ litres} \checkmark$$

The volume is determined by multiplying 3 sides, therefore the units are always cubed.

QUESTION 4

4.1

$$\text{Area} = \text{length} \times \text{breadth}$$

$$= 30 \text{ cm} \times 45 \text{ cm}$$

$$= 1\,350 \text{ cm}^2 \checkmark \checkmark$$

4.2

$$\text{Perimeter} = 2(\text{length} + \text{breadth}) \checkmark$$

$$= 2(30 \text{ cm} + 45 \text{ cm}) \checkmark$$

$$= 2(75 \text{ cm})$$

$$= 150 \text{ cm} \checkmark$$

QUESTION 5

5.1

21 members \checkmark

5.2

$$\text{Water needed} = 3 \times 1000 \checkmark$$

$$= 3000 \text{ ml}$$

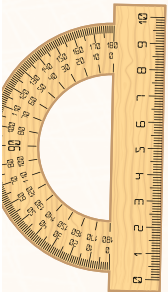

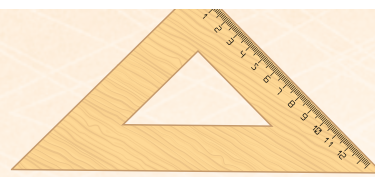

5.3 Weight of teabags = $40 \text{ g} \times 10$
 $= 400 \text{ grams} \checkmark$
 $= 400 \div 1000 \checkmark$
 $= 0.4 \text{ kg}$

5.4 No. of teaspoons/teapot = 15×2
 $= 30 \checkmark$

No. of teaspoons per cup = $30 \div 10 \checkmark$
 $= 3 \text{ teaspoons} \checkmark$

5.5 No. of teapots needed = $1+1+1 = 3 \checkmark$
 No. of tablespoons needed = $3 \times 15 \checkmark$
 $= 45 \checkmark$

Number of teapots needed is 3, since there are 21 members and 1 teapot serves 10 people.

5.6 $^{\circ}\text{C} = (^{\circ}\text{F}-32) \div 1.8$
 $= (212-32) \div 1.8 \checkmark$
 $= 100^{\circ}\text{C} \checkmark$

5.7 $10:08 - 27 \text{ minutes} = 09:41 \checkmark \checkmark$

5.8.1 Length = $1.5+4+4+4+1.5 = 15 \text{ cm} \checkmark$

Width = $1.5+4+4+4+1.5 = 15 \text{ cm} \checkmark$

Height = $5.5+1.5 = 7 \text{ cm} \checkmark$

5.8.2 Surface area = $2(15 \times 15) + 2(15 \times 7) + 2(15 \times 7) \checkmark$
 $= 450+210+210 \checkmark$
 $= 870 \text{ cm}^2 \checkmark$

5.8.3 Cost = $(870 \times \text{R}0.04) \checkmark \checkmark$
 $= 34.80 + (34.80 \times 0.14) \checkmark$
 $= 34.80 + 4.872 \checkmark$
 $= \text{R}39.67 \checkmark$



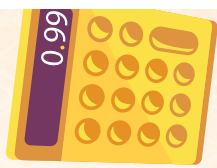

QUESTION 6

6.1 $SA = (0,6 \times 0,4) \checkmark + 2(0,6 \times 1) \checkmark + 2(0,4 \times 1) \checkmark$
 $= 2,24 \text{ m}^2$

$3 \text{ m}^2 \checkmark$

6.2 $35 \text{ cm} = 0,35 \checkmark_c$

$SA = (3,14 \times 0,35^2) \checkmark + (2 \times 3,14 \times 0,35 \times 1) \checkmark$

$= 3,297 \text{ m}^2 \checkmark$

$4 \text{ m}^2 \checkmark$

6.3.1 Diameter = $2,5 + 2 \times 0,2 = 2,9 \text{ m} \checkmark \checkmark \checkmark$

Circumference = $2 \times 3,14 \times 1,45 \checkmark \checkmark$

$= 9,106 \text{ m}^2 \checkmark$

Therefore, she needs to buy **10m²** for 1 tablecloth. \checkmark

6.3.2 Cost = $10 \times 10 \times 12 \checkmark = \text{R}1200 \checkmark$

6.4.1 $135 \times \frac{125}{100} \checkmark = \text{R}168,75 \checkmark$

OR

$135 + \frac{25}{100} \times 135 \checkmark = \text{R}168,75 \checkmark$

6.4.2 $168,75 \times 10 \checkmark = 1687,50 \checkmark$

$1687,50 \times \frac{95}{100} \checkmark = \text{R}1603,13 \checkmark$

QUESTION 7

7.1 $V = 5 \text{ cm} \times 0,05 \text{ cm} \times 10 \text{ cm}$

$V = 5 \text{ cm} \times 5 \text{ cm} \times 10 \text{ cm} \checkmark$

$V = 250 \text{ cm}^3 \checkmark$

7.2 $A = (5 \text{ cm} \times 5 \text{ cm}) \times 2 = 50 \text{ cm}^2 \checkmark \checkmark$

$A = (5 \text{ cm} \times 10 \text{ cm}) \times 4 = 200 \text{ cm}^2 \checkmark$

$SA = 200 \text{ cm}^2 + 50 \text{ cm}^2 = 250 \text{ cm}^2 \checkmark \checkmark$

7.3 $1 \text{ ml} = 1 \text{ cm}^3$

$250 \text{ ml} = 250 \text{ cm}^3 \checkmark$

$X =$

$= 0,25 \text{ l} \checkmark \checkmark$



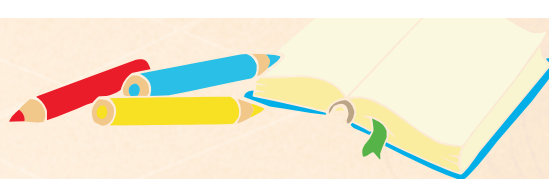
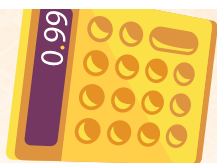

3.4 DATA-HANDLING

Make sure that you are able to:

- Understand terminology such as mode, mean, range, quartile, etc.
- Arrange data in ascending order.
- Identify the mode.
- Determine the median when data is already arranged in ascending order and n is odd ($n = \text{number of scores}$).
- Construct frequency tables from arranged data.
- Read information from graphs and frequency tables.
- Construct tally tables.
- Calculate the mean and the range of given scores and quartiles, and analyse percentiles.
- Draw graphs from given data (these graphs include pie charts, single and compound bar graphs, line and broken line graphs, and histograms).

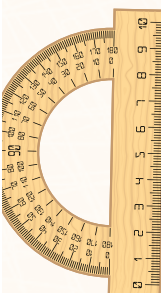



Glossary for Data Handling

TERMS	MEANING
Bar graph	90° graph using bars to show frequency (horizontal and vertical graph). The vertical height of a set of bars of equal breadth represent the values of the dependant variable in a data set.
Box-and-whisker plot	A diagram that statisticians use to show the distribution of data along a number line divided into quartiles.
Certain	Something is definitely going to happen, e.g. getting heads or tails when tossing a coin is certain.
Classify	Identify the category or class.
Compound events	Two or more events that happen, e.g. tossing a coin and rolling a dice.
Contingency table	A two-way table representing the outcome of an event.
Continuous data	Numerical data (e.g. measurements like weight or age).
Data	Information, a series of observations, measurements, facts; collecting and recording information for purposes of statistical investigation.
Data collection sheet	Two-column table showing what is observed and how many times it was observed; items of information.
Discrete	Separate; distinct; the opposite of continuous.
Discrete data	Numerical data (fixed numbers, like size of family); data that can have only certain values (quantities that can be counted, usually whole numbers)
Equivalent	Quantities that have the same value.
Estimate	Roughly work out; roughly calculate.
Even	The chances of any outcome happening are equal; if a normal six-sided dice is rolled, the chance that any one of the numbers (1, 2, 3, 4, 5 or 6) could show is the same.
Event	An activity, e.g. rolling a single dice.
Fifty-fifty (even) outcome	The chances of something happening or not happening are the same.
Frequency (f)	The number of times a data value is recorded.
Frequency table	A table showing frequencies in an organised form; a table that summarises the frequencies of all the data values in a data set.
Group	Put into classes / sort / arrange / organise.
Histogram	90° graph using adjacent bars to show the frequency of numerical data grouped into intervals; where areas of rectangles (continues; no gaps between them) show frequency of classes of data (breadth 5 class; height 5 frequency).
Horizontal bar graph	90° bar graph using horizontal bars to compare or rank items like household sizes in a block of flats.
Impossible outcome	No chance of the outcome happening, e.g. getting a 7 with an ordinary six-sided dice.
Interview	Record data by talking to someone face-to-face or over the telephone.
Investigate	Examine; look into; study.
Likely/likelihood	The chance of something happening is greater than the chance of it not happening.
Mean	The average of the values in a data set; sum of all the observed values divided by the number of observations.
Mean [of a set of data]	The average; the sum of all data values divided by the number of data values.



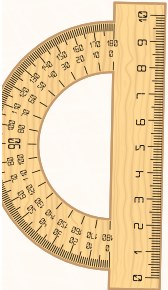
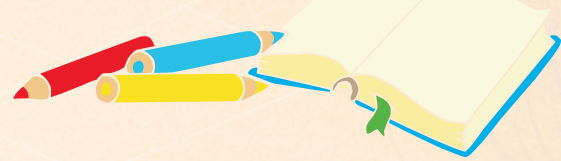
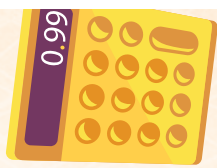

Measures of central tendency	Numbers that tell more about the balance (middle values) in a data set (mode; median; mean).
Measures of spread	Numbers that tell how far apart data values in a data set lie ; the spread of a numerical data set (range, quartiles, percentiles).
Median	The middle value in an ordered data set.
Median [of a set of data]	The value that cuts an ordered data set in half.
Mode	The value or values appearing most often in a data set.
Mode of a set of data	The most common data value in a data set.
Notation	A system of figures/symbols used to represent numbers, quantities or values.
Observation	Recording of data by watching someone or something closely.
Outcome	Result of a trial (experiment).
Outcome [fair]	All outcomes are equally likely to occur.
Outliers	A data value that lies an abnormal distance from the other data values in a data set.
Population	The entire source of data involved in an investigation; all the subjects included in a study or survey from which conclusions will be drawn about that population as a whole.
Possible outcome	The chance that an event will occur.
Prediction	A statement describing the chance of an outcome happening, based on given information.
Probability [mathematical]	The results of a trial or experiment expressed as a fraction: the number of favourable outcomes divided by number of all possible outcomes.
Probability [of an outcome]	The likelihood of a particular outcome occurring, expressed as a number between zero and one.
Quartiles	The values that divide a list of numbers into four equal parts.
Questionnaire	A list of questions that can be used to collect data.
Range [of a data set]	The difference between the highest and lowest values in a data set.
Related [data sets]	Linked; connected.
Represent[data]	Draw; graph.
Representative sample	A sample that is likely to give results similar to what would be obtained by studying the whole population.
Sample	A sub-set (small group) chosen from the population to represent the population.
Sampling	Choosing a representative sample.
Sort	Put / organise into categories.
Survey	Collect data from a group of people or objects.
Survey [biased]	Survey containing factors that produce answers that do not represent a truthful picture of the situation.
Tree diagram	A diagram that uses using branches to display all the outcomes of a series of trials.
Two-way table	A contingency table that represents all possible outcomes of two trials taking place together.
Unlikely	The chance of something happening is less than the chance of it not happening.
Variable	A number or quantity that can have different values in a situation.
Vertical bar graph	A 90° bar graph that uses vertical bars to show change over time at discrete times, e.g. absentees per day for three weeks.
Very likely	The chance of something happening is much greater than the chance of it not happening.
Very unlikely	The chance of something not happening is much greater than the chance of it happening.



3.4.1 Exemplar Questions for Data Handling

Question 1

Study the pie charts below that show a municipality's service delivery for a particular period, then answer the questions that follow.

Households 324 292

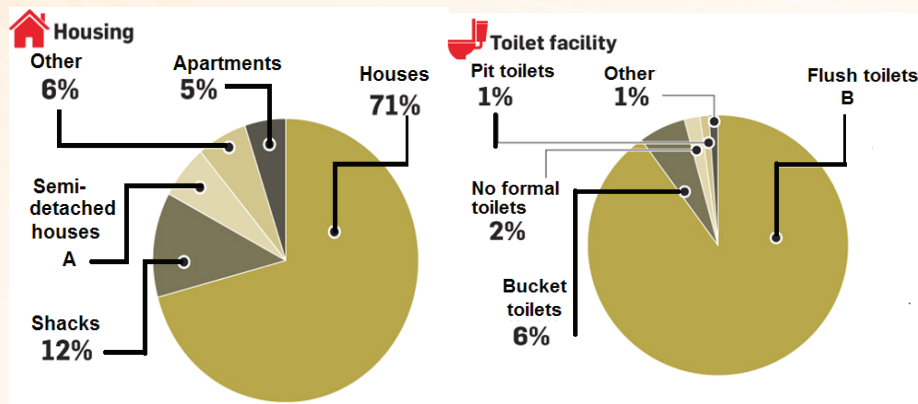

- 1.1.1 Calculate the missing values of A and B. (4)
- 1.1.2 Determine the number of households using bucket toilets. (3)
- 1.1.3 Determine the number of shacks in the municipality. (3)
- 1.1.4 Is the data above an example of discrete or continuous data? (3)
Give a reason for your answer. (3)
- 1.1.5 Write the number of houses as a ratio to the number of: (2)
 - (a) Apartments (2)
 - (b) Shacks (2)
- 1.2 Study the box-and-whisker plots below, which represent the age of people who viewed three different films; then answer the questions that follow:

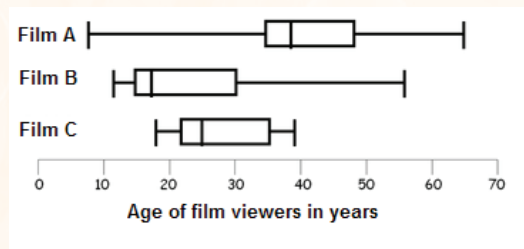

- 1.2.1 Write down the median age of a viewer who viewed Film A. (2)
- 1.2.2 Determine the age of the youngest person who viewed Film B (2)
- 1.2.3 Which film was viewed by a 65-year-old person? (2)

QUESTION 2

2.1

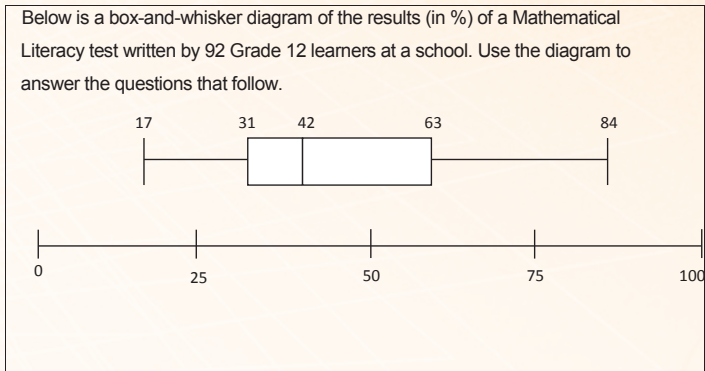

- 2.1.1 What is the highest mark obtained? (2)
- 2.1.2 What percentage of learners obtained more than 42%? (2)
- 2.1.3 How many learners obtained more than 63%? (2)
- 2.1.4 Determine the inter-quartile range. (2)
- 2.1.5 How many learners obtained between 31% and 63%? (2)

2.2 A number of participants in a cycle race recorded their hours training as well as their 2014 results for the race in the following table:

Cyclist number	1	2	3	4	5	6	7	8	9
Training time in hours	20	18	16	17	19	13	12	9	15
2014 results (minutes)	203	285	245	256	230	297	210	310	255

- 2.2.1 Display the information in a scatter plot on the answer sheet provided. (2)
- 2.2.2 In the sample above, how many hours of training did the cyclist who took the longest time to complete the race do? (2)
- 2.2.3 Which of the nine cyclists had the best results in the race? Explain your choice. (2)
- 2.2.4 Identify the type of correlation between training hours and time taken to complete the race. (2)

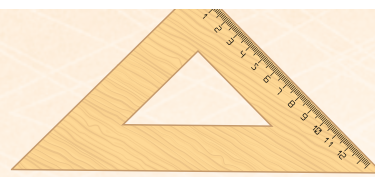

ANSWER SHEET

Question 2.2.1

QUESTION 3

3.1 The table below shows information collected on a group of car accidents. The information was collected through interviews with senior metropolitan policemen and policewomen.

Frequency of accidents in the past year 18 - 28	Age and gender of driver						Row totals
	29 - 39		40 - 50				
	Male	Female	Male	Female			
0	124	146	135	154	159	153	871
1	52	43	43	28	28	35	229
2	24	11	22	18	13	12	100
Total	200	200	200	200	200	200	1 200

- 3.1.1 How many people were interviewed? (2)
- 3.1.2 How many of the people were males of those who were interviewed in the age group 18 – 28? (2)
- 3.1.3 How many of the people that were interviewed had been involved in two car accidents in the past year? (2)
- 3.1.4 If a motor vehicle driver is randomly selected from the interviewed group, what is the probability that the driver: (Give your answer as a percentage, rounded to one decimal point.) (2)
- (a) Had one motor accident in the past year? (2)
- (b) Is a male in the age group 18 - 28 and had one car accident in the past year? (2)
- (c) Is a male who had one motor accident in the past year? (2)
- 3.2 The following data on traffic at Mall of Africa was provided by Graphics 24.



Mall of Africa's foot traffic and vehicles

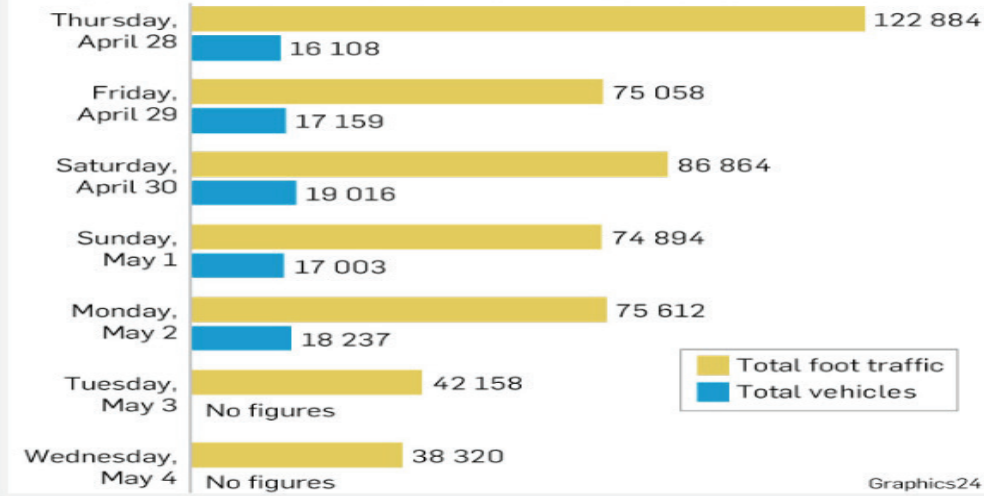

- 3.2.1 Name the type of graph being used above. (2)
- 3.2.2 According to the graph above, on which day were there the most vehicles? (2)
- 3.2.3 How many vehicles visited the Mall of Africa over the seven-day period? (3)
- 3.2.4 Determine the total foot traffic to the mall over the week-end. (2)

QUESTION 4

- 4.1. The sports organiser of Mano Secondary School conducted a survey on the weight and height versus the age of girls at the school. He calculated the Body Mass Index (BMI) of a sample of girls from the population at the school. There were 365 girls at the schools.

Table 1: Age, mass and height of surveyed learners

Learner	Age (years)	Height (m)	Mass (kg)	BMI
Vuyo	14	1,65	65	23,9
Glynis	18	1,7	72	P
Doris	16	1,62	68	25,9
Yolanda	16	1,5	65	Q
Mpho	18	1,55	72	29,95
Tsakane	15	1,56	66	27,1
Refilwe	16	1,55	62	25,8
Norah	17	1,58	63	25,2
Siba	15	R	69	27
Noni	16	1,55	53	22,1
Yonela	17	1,66	81	29,4
Amanda	19	1,63	71	26,7

- 4.1.1 Determine the range of the ages of the girls in the sample. (2)
- 4.1.2 Use the formula: $BMI = \frac{Weight (kg)}{Height (m)^2}$ to calculate: (3)
- (a) P (2)
- (b) Q (2)

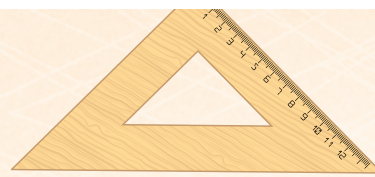

(c) R

(2)

4.2 BMI is used to determine the weight status of individuals. The sports organiser used the following BMI growth chart for girls to determine the weight status for this sample.

Use Table 1 above and the BMI age growth chart below to answer the questions below.

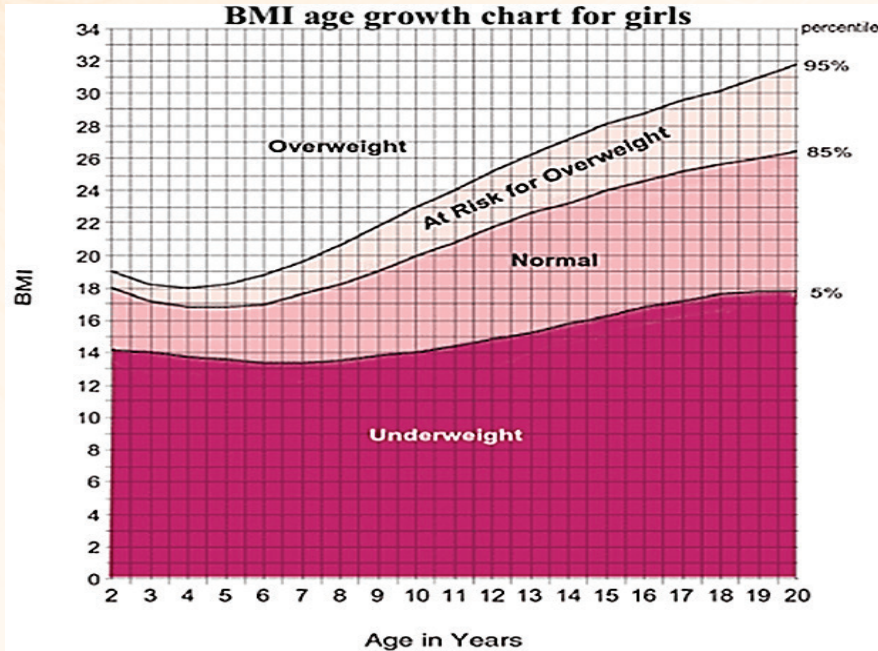

4.2.1 Determine Tsakane's weight status.

(2)

4.2.2 Determine the number of 16-year-old girl(s) whose weight status lies between the 5th and 85th percentile.

(2)

4.2.3 What is the weight status of girl(s) in 2.2.2 above?

(2)

4.2.4 Amanda is worried about her weight status. She wants her status to be normal.

(a) What is Amanda's current weight status?

(2)

(b) Calculate the minimum number of kilograms Amanda must lose to reach a normal weight status.

(4)



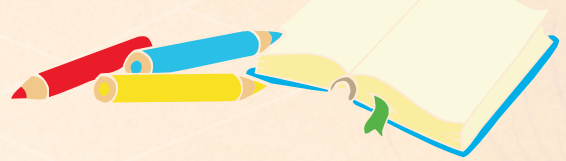
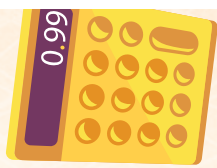

QUESTION 5

5.1 The stacked bar graph below shows the number of learners in each grade at Mama Lumka's Aftercare.

Number of learners at Mama Lumka's Aftercare

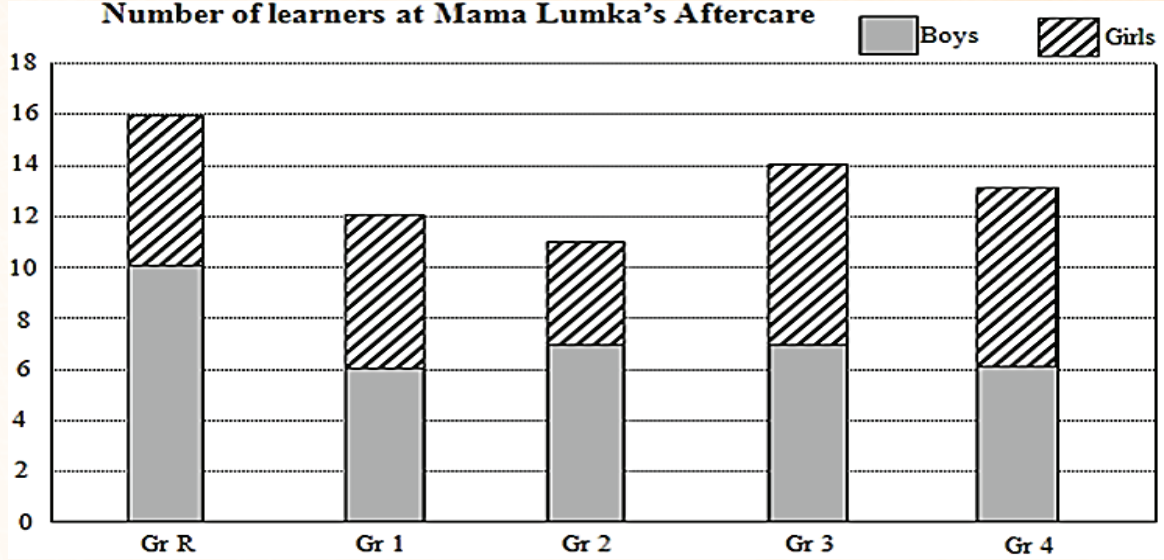

- 5.1.1 How many learners are there in the grade 2 aftercare class? (2)
- 5.1.2 How many more boys than girls are there in grade R? (2)
- 5.1.3 What percentage of learners in Mama Lumka's Aftercare is in grade 4? (4)
- 5.1.4 What is the average (mean) number of boys per grade? (3)

5.2 Tshawe uses seashells to make ornaments. He measured the width, in millimetres, of a few seashells and recorded his findings as follows:

11	8	11	13	10	9	7	14
12	13	12	8	7	9	10	12
13	12	13	14	12	10	10	9
15	12	11	10	12	14	11	12
10							

- 5.2.1 Determine the modal width of the shells. (2)
- 5.2.2 Calculate the range of the width of the shells. (2)

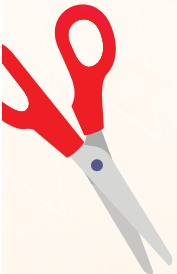
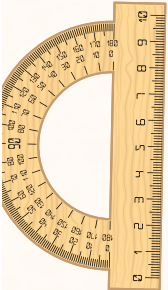



Question 6

Kidi, Pelo and Tumi had enrolled for a 12-month project management programme at Lumcet Varsity College. The students are required to write a test each month for nine months; these are used to calculate the year mark. The table below shows the record of the marks for the three students. Study the table and answer the following questions.

Test Scores in Percentage									
Kidi	P	93	92	88	86	82	80	76	72
Pelo	68	Q	62	64	63	68	55	68	58
Tumi	60	64	76	R	76	66	68	80	62

- 6.1. Determine the value of **P** - Kidi's maximum score, if the range of her scores is 24. (2)
- 6.2. What is the median for Pelo's readings if the total of the scores recorded was 562. (5)
- 6.3. If Tumi's mean score is 67. Calculate:
 - 6.3.1. the value of **R** (3)
 - 6.3.2. her range score (3)
- 6.4. Write the combined modal scores for Kidi and Tumi. (2)
- 6.5. Who is the best achiever? Justify your answer with calculations. (4)
- 6.6. Determine the interquartile range for Tumi's recorded scores. (5)



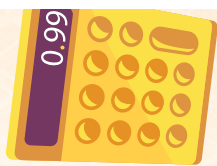

Question 7

A survey was conducted to determine the quantity of water that a typical single-family home uses. The results were represented in a pie chart, which is shown below.

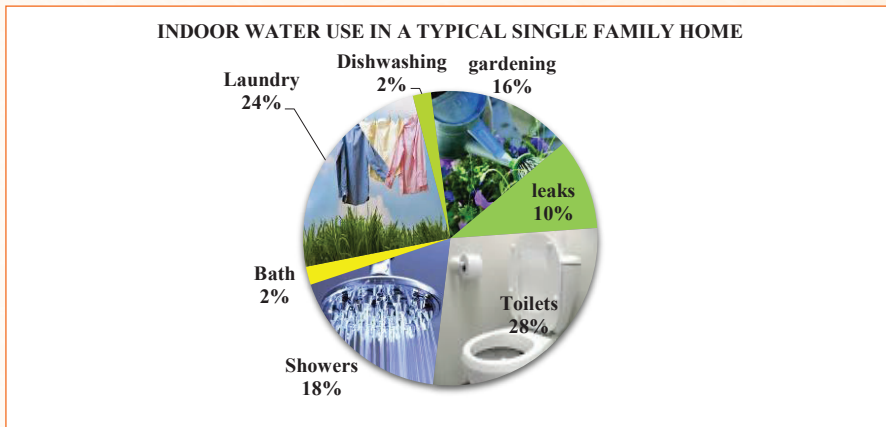

- 7.1. Write the ratio of water used for dishwashing to that used in toilets. (2)
- 7.2. Which type of indoor activity uses most water? (2)
- 7.3. Determine the percentage of water lost through leaks. (2)
- 7.4. Write the water usage for showers as a fraction of total household water usage. (2)
- 7.5. If the household used 18 kilolitres of water in a certain month, calculate the actual quantity that each household activity used. (2)

3.4.2 Possible Answers for Data Handling

Ques Solution

1.1.1 $A = 100\% - (71\% + 5\% + 6\% + 12\%) \checkmark$
 $= 100\% - 94\%$
 $= 6\%$

The pie chart will always add up to 100, when expressed in %. So A will be the difference of the whole and the given items.

$B = 100\% - (6\% + 2\% + 1\% + 1\%) \checkmark$
 $= 100\% - 10\%$
 $= 90\% \checkmark$

Refer to the notes above.

1.1.2 Number of households using bucket toilets

$= 324\,292 \times 6\% \checkmark$

The Number of households using bucket toilets in this case will be the 6% of the whole. Note that the 6% is given in the chart

$= 19\,457,53 \checkmark$

The number cannot be in decimals, because one cannot have a part of the household. Always read the instructions carefully

$\approx 19\,458 \checkmark$

Follow the instruction in the Question Paper: 'round off ALL final answers appropriately according to the given context,



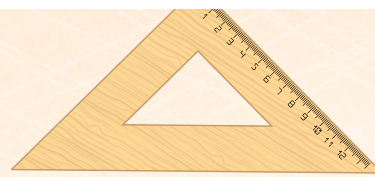

1.1.3 Number of shacks in the municipality

$$= 324\,292 \times 12 \quad \checkmark$$

$$= 38\,915,04 \checkmark$$

$$\approx 38\,915 \quad \checkmark$$

Refer to the notes in 1.1.2.

1.1.4 Discrete. $\checkmark\checkmark$

The number of houses cannot be expressed as a fraction. \checkmark

A similar question appeared in the 2016 NSC paper 1 - Q 4.2.1. It was poorly answered. Learners MUST be able to define the continuous and discrete data.)

1.1.5 (a) 71% : 5% $\checkmark\checkmark$

(b) 71% : 12% $\checkmark\checkmark$

The median is the vertical line that divides the box as read from the horizontal

1.2.1 39 years of age $\checkmark\checkmark$

The end of the left whisker.

1.2.2 11 years of age $\checkmark\checkmark$

1.2.3 Film A $\checkmark\checkmark$

2.1.1 84% $\checkmark\checkmark$

2.1.2 50% $\checkmark\checkmark$

2.1.3 23 learners $\checkmark\checkmark$

2.1.4 IQR

$$= \text{Upper quartile (Q3)} - \text{Lower quartile (Q1)} \quad \checkmark$$

$$= 63\% - 31\%$$

$$= 32\% \quad \checkmark$$

It is important to know that the IQR is the difference between the upper and the lower quartile.

2.1.5 43 learners $\checkmark\checkmark$

2.2.1

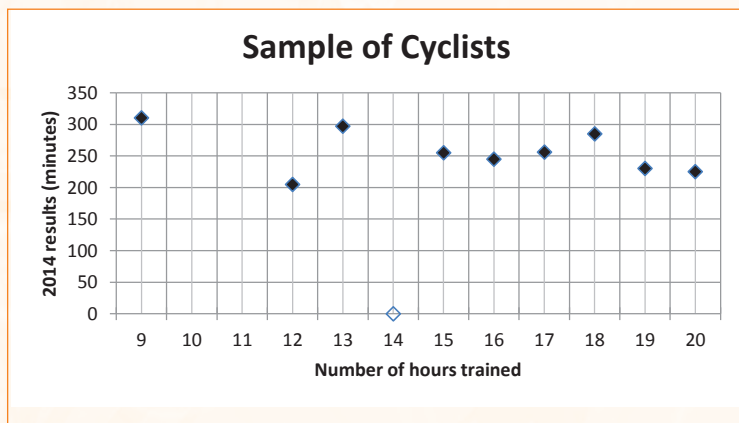

2.2.2 9 hours $\checkmark\checkmark$

2.2.3 Cyclist number 1 performed best, because he/she completed the race in the shortest time. $\checkmark\checkmark$

2.2.4 There is no correlation. $\checkmark\checkmark$

There is no pattern on the plotted points.

Points are scattered all over the graph.

The more hours trained, the less time taken to complete the race.

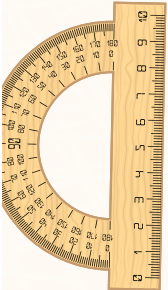
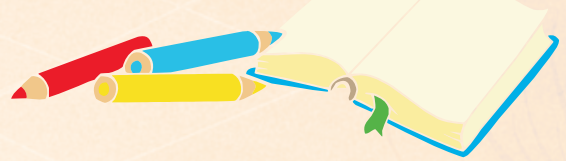
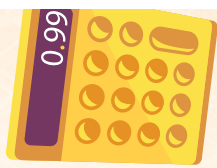

Ques	Solution
3.1.1	1 200✓✓
3.1.2	200✓✓
3.1.3	100✓✓
3.1.4	$\frac{229}{1200} \times 100\%$ ✓
(a)	= 19,1%✓
3.1.4	$\frac{52}{1200} \times 100\%$ ✓
(b)	= 4,3%✓
3.1.4	$\frac{123}{1200} \times 100\%$ ✓
(c)	= 10,3%✓
3.2.1	Horizontal Bar Graph ✓✓
3.2.2	Thursday✓✓
3.2.3	Number of vehicles = 122 884 + 75 058 + 86 864 + 74 894 + 75 612 + 42 158 + 38 320✓ = 515 790✓
3.2.4	Week-end foot traffic = 19 016 + 17 003✓ = 36 019✓

When using a calculator, enter the fraction and multiply by 100 and do not multiply by 100%. When calculating percentages, the % symbol must be included in the final answer.

Know the names and shapes of ALL the types of graphs.



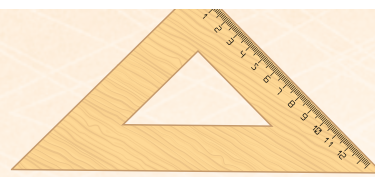

4.1.1. Range = 19 – 14✓

= 5✓

4.1.2 (a) BMI = $\frac{72}{1,7^2}$ ✓

P = 24,9✓

(b) BMI = $\frac{65}{1,5^2}$

Q = 28,9✓

(c) BMI = $\frac{\text{weight (kg)}}{\text{height}^2}$

27 = $\frac{69}{R^2}$

$R^2 = \frac{69}{27}$

= 2,55555555

R = 1,60✓

4.2.1 Overweight✓✓

4.2.2 1✓✓

4.2.3 Normal✓✓

4.2.4 (a) overweight✓✓

(b) For normal weight: BMI = 26✓

BMI = $\frac{\text{weight (kg)}}{\text{height}^2}$

Weight = 26

= 69,1 kg✓

Minimum weight loss = 71 – 69,1✓

= 1,9 kg✓

5.1.1. 11 learners✓✓

5.1.2 4 more boys than girls✓✓

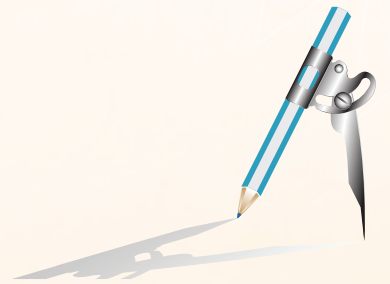

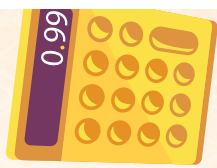

5.1.3 Total number of learners
 $= 16 + 12 + 11 + 14 + 13 \checkmark$
 $= 66$

Percentage of grade 4 learners

$$= \frac{13}{66} \checkmark \times \frac{100}{1} \checkmark$$

$$= 19,7\% \checkmark$$

5.1.4 Mean = $\frac{10+6+7+7+6}{5} \checkmark \checkmark$

$$= \frac{36}{5}$$

$$= 7,2 \checkmark$$

5.2.1 Mode = 12 $\checkmark \checkmark$

5.2.2 Range = $15 - 7 \checkmark$

$$= 8 \checkmark$$

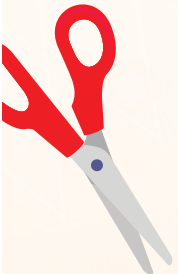
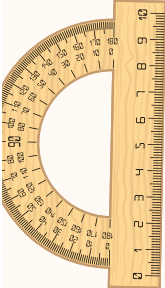

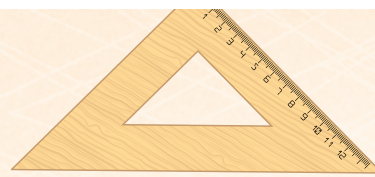

Total number of medals of the top 5 countries

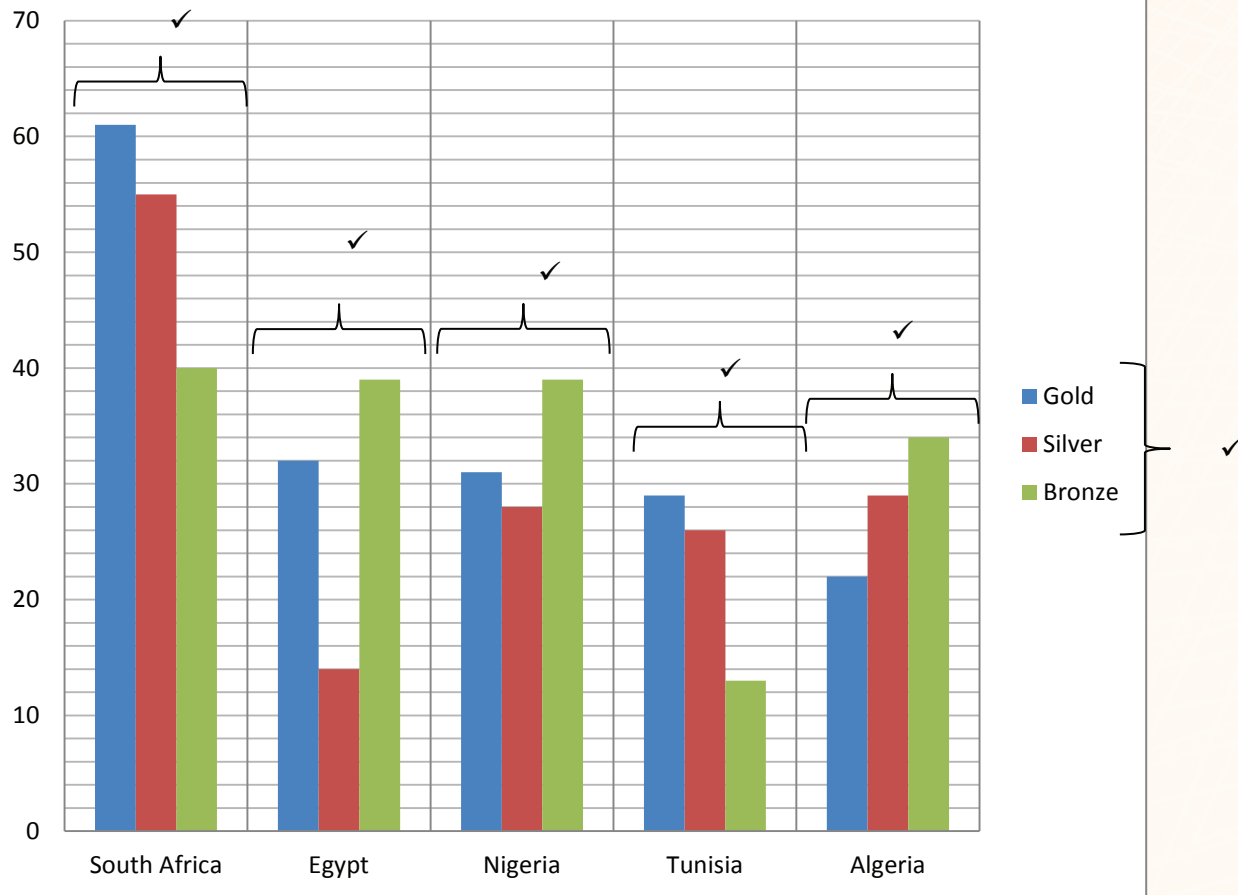

6.1. Range = Max. – Min.

$$24 = 96 - 72 \checkmark$$

$$P = 96 \checkmark$$

The data must always be sorted. Range = highest value less lowest value. Also practice the reverse calculation. A similar question appeared in the 2016 NSC P2 - Q 3.2.1

6.2. $68 + 68 + 68 + 64 + 63 + 62 + 58 + 55 + Q = 562 \checkmark$

$$Q = 562 - 506 \checkmark$$

$$= 56 \checkmark$$

Arranged data

$$68; 68; 68; 64; 63; 62; 58; 56; 55 \checkmark$$

The median is 63. \checkmark

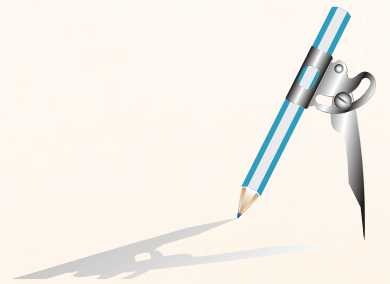

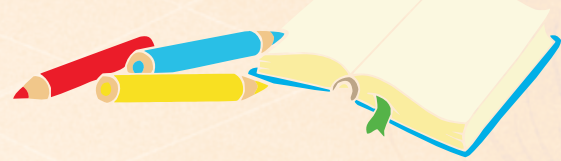
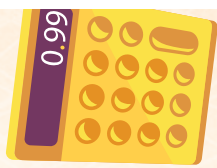

$$6.3.1 \quad 63 = \frac{80+76+R+76+62+68+66+64+60}{9}$$

$$657-552 = R \checkmark$$

$$\therefore R = 51 \checkmark$$

$$6.3.2 \quad 80;76;76;68;66;64;62;60;51 \checkmark$$

$$\text{Range} = 80 - 51 \checkmark$$

$$= 29 \checkmark$$

$$6.4. \quad 76 \checkmark \checkmark$$

$$6.5. \quad \text{Range for Kidi is } 24 \checkmark \checkmark$$

$$\text{Range for Pelo is } 95-68=27 \checkmark \checkmark$$

$$\text{Range for Tumi is } 80-51=29 \checkmark \checkmark$$

\therefore Tumi is the best achiever \checkmark

$$6.6 \quad Q_1 = \frac{64+60}{2} \checkmark$$

$$= 62 \checkmark$$

$$Q_3 = 76 \checkmark$$

$$\text{IQR} = 76 - 62 \checkmark$$

$$= 14 \checkmark \checkmark$$

7.1. The ratio of water used for dishwashing to that used for toilets $2\% : 28\% = 1 : 14 \checkmark \checkmark$

7.2. The type of indoor activity that uses most water is toilets.

7.3. 10% of water is lost through leaks. $\checkmark \checkmark$

7.4. Water used for showering as a fraction of total household water usage - $18/100 = 9/50. \checkmark \checkmark$

7.5

Indoor water usage

Type of activity	Actual water used
Dishwashing	$\frac{2}{100} \times 18 = 0,26\text{kl}$
Gardening	$\frac{16}{100} \times 18\text{kl} = 2,88\text{kl}$
Leaks	$\frac{10}{100} \times 18\text{kl} = 1,8\text{kl}$
Toilets	$\frac{28}{100} \times 18\text{kl} = 5,04\text{kl}$
Showers	$\frac{18}{100} \times 18\text{kl} = 3,24$
Bath	$\frac{2}{100} \times 18\text{kl} = 0,26\text{kl}$
Laundry	$\frac{24}{100} \times 18\text{kl} = 4,32\text{kl}$





4 STUDY AND EXAMINATION TIPS

A) Generic

- Time management, etc.
- This should be the same for all subjects.
- DBE to draft

B) Subject specific

Paper 1: This paper is 3 hours long and is out of 150 marks. It will consist of five questions. Basic content knowledge will be required to answer the questions, i.e. even the context will be restricted to what is in the CAPS document. Four of the questions will be topic specific and one question will be an integrated question.

Paper 2: This paper is also 3 hours long and is out of 150 marks. It will consist of between four and six questions. These questions will require more interpretation and application of the information provided. Context is not restricted to that which is in the CAPS document.

ASSESSMENT IN GRADE 12

Time and mark allocation

TABLE 1 below indicates the time allowed and the mark allocation for the two question papers for Mathematical Literacy in Grade 12:

TABLE 1: Time allowed and mark allocation for Grade 12 question papers

PAPER	TIME	MARKS
Paper 1	3 hours	150 marks
Paper 2	3 hours	150 marks



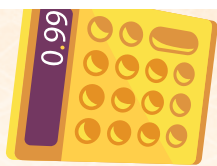

Format of the question papers

The table below shows a summary of the differences between Paper 1 and Paper 2.

TABLE 2: Summary of the differences between Paper 1 and Paper 2		PAPER 2
Intention	'Basic skills' paper → assesses proficiency regarding content and/or skills.	'Applications' paper → assesses ability to use both mathematical and non-mathematical techniques/ considerations to explore familiar and unfamiliar contexts.
Structure and scope of content and/or skills	<p>5 questions</p> <p>Four questions deal with contexts relating to each of the topics:</p> <ul style="list-style-type: none"> • Finance • Measurement • Maps, plans and other representations of the physical world • Data handling <p>The fifth question integrates content from all these topics.</p> <p>Likelihood will be examined in the context of one or more of the other questions.</p> <p>Each question can contain more than one context.</p>	<p>4 or 5 questions</p> <p>Each question deals with contexts drawing integrated content from across all of these topics:</p> <ul style="list-style-type: none"> • Finance • Measurement • Maps, plans and other representations of the physical world • Data handling <p>Likelihood will be examined in the context of one or more of the other questions.</p> <p>Each question can contain more than one context.</p>
Taxonomy levels	Level 1	60%
	Level 2	25%
	Level 3	35%
	Level 4	40%
Contexts	'Familiar', i.e. limited to the contexts listed in the CAPS document.	Both 'familiar' and 'unfamiliar', i.e. not limited to the contexts listed in the CAPS document.

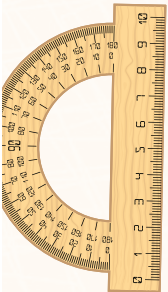

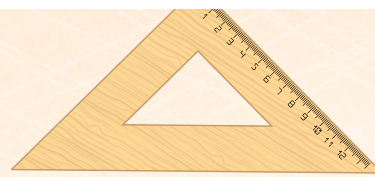

5 MESSAGE TO GRADE 12 LEARNERS FROM THE WRITERS

Naughty 'Ngwato' Mbanyane (Gauteng Province)

Hard work and a good dose of determination and dedication can lead you *anywhere*, even if you are not the most talented in this area. Think about all those super talents in your preferred area of education. Only those talented individuals who are willing to make an extra effort will be able to succeed. Otherwise, less talented people will out-perform them with their boundless willingness to do everything they can in order to succeed.

“Hard work beats talent, when talent doesn't work hard.” Tim Notke

Zandile Mdiniso (KwaZulu-Natal Province)

Your positive actions, combined with positive thinking, results in success - so work hard and stay positive. Remember, success demands five things: hard work, sacrifice, struggle, faith and patience.

“A man can be as great as he wants to be. If you believe in yourself and have the courage, the determination, the dedication, the competitive drive, and if you are willing to sacrifice the little things in life and pay the price for the things that are worthwhile, it can be done.” Vince Lombardi

Pule Mokoena (Mpumalaga Province)

Teachers affect eternity, but cannot tell where their influence stops. A batton is passed and must be taken with the hands. Be inspired, always have hope, have ignited imagination and love learning to have wisdom.

“Teaching is a great act of optimism.” Colleen Wilcox



32%



Mathematics



Accounting

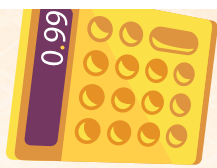

6 CONCLUDING REMARKS AND ACKNOWLEDGEMENTS

The Mathematical Literacy Exam Preparation Booklet was developed by Ms Zandile Mdiniso, Mr Pule Mokoena and Mr Naughty Mpanyane (Subject Specialists, PED)

A special mention must be made to Mr Thomas Masango, the DBE curriculum specialist who, in addition to his/her contribution to the development of the booklet, co-ordinated and finalised the process.

These officials contributed their knowledge, experience and in some cases unpublished work which they have gathered over the years to the development of this resource. The Department of Basic Education (DBE) gratefully acknowledges these officials for giving up their valuable time, families and knowledge to develop this resource for the children of our country.

Administrative and logistical support was provided by: Ms Martha Netshipale, Mr Itumeleng Jikolo, Ms Zanele Mkwanazi and Mr Noko Malope. These officials were instrumental in the smooth and efficient management of the logistical processes involved in this project.

Book III

Look out for Book II which will help you get from 60% to 80% or even 100% - wouldn't that be amazing.



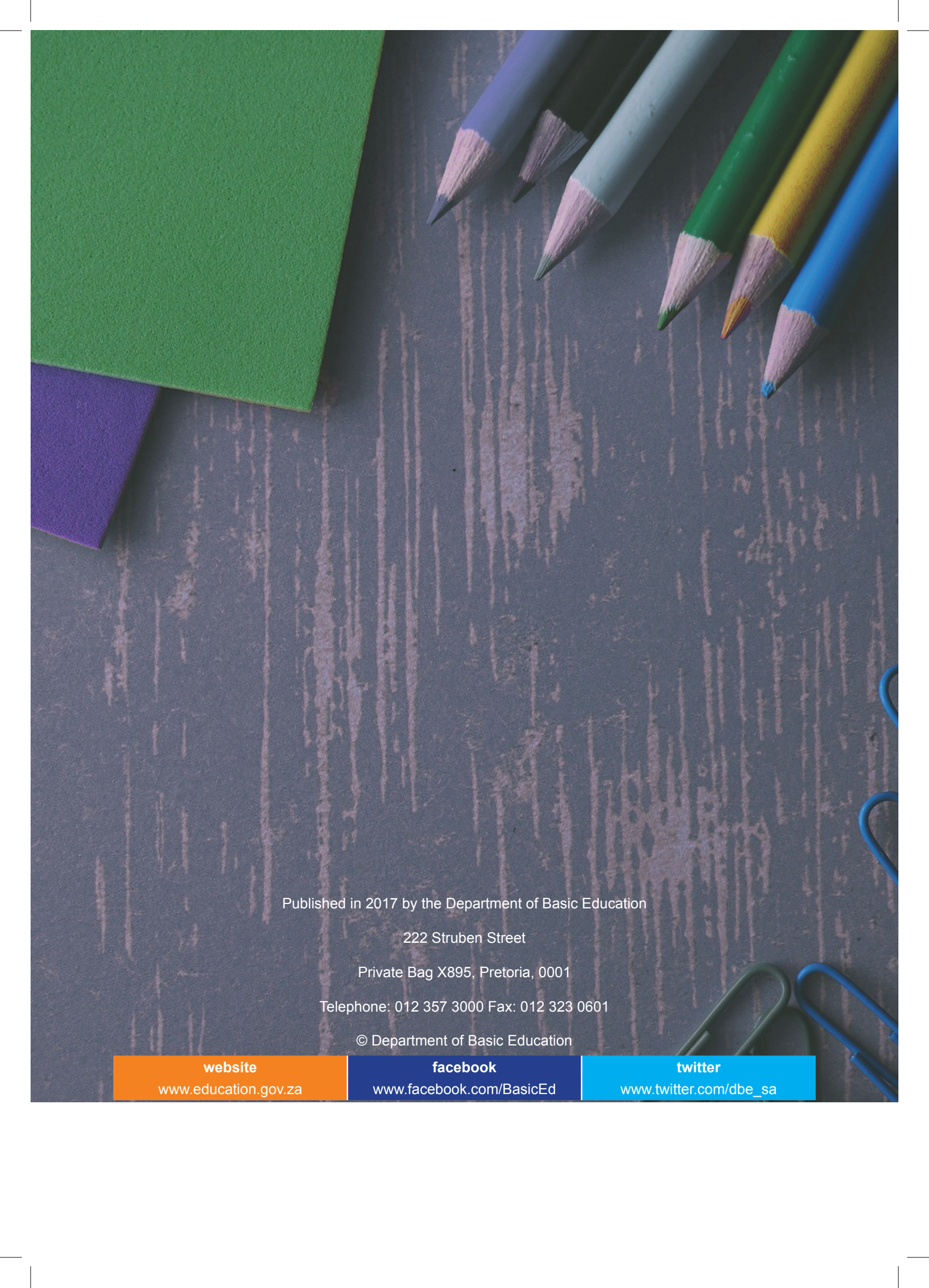

A photograph of school supplies including colored pencils and paper clips on a wooden desk. The pencils are in shades of purple, light blue, green, yellow, and blue. The paper clips are green and blue. The background is a dark wood-grain surface. In the top left corner, there are pieces of green and purple paper.

Published in 2017 by the Department of Basic Education

222 Struben Street

Private Bag X895, Pretoria, 0001

Telephone: 012 357 3000 Fax: 012 323 0601

© Department of Basic Education

website

www.education.gov.za

facebook

www.facebook.com/BasicEd

twitter

www.twitter.com/dbe_sa