



Province of the
EASTERN CAPE
EDUCATION

INTERMEDIATE PHASE

GRADE 6

NOVEMBER 2016

MATHEMATICS

MARKS: 75

TIME: 1½ hours

NAME: _____



This question paper has 13 pages.

INSTRUCTIONS AND INFORMATION

1. Read ALL the questions carefully.
2. QUESTION 1 consists of 10 multiple-choice questions. Circle the letter with the correct answer.
3. Answer QUESTIONS 2 to 27 in the spaces or frames provided.
4. All working must be done on the question paper and not on rough paper.
5. The test counts 75 marks.
6. The test duration is 1½ hours.
7. The teacher will lead you through the practice exercise before you start the test.
8. You may NOT use a calculator.

PRACTICE EXERCISE

Circle the letter with the correct answer.

Calculate: $7 \times 5 = \dots$

- A 12
- B 35
- C 75
- D 57

You have answered correctly if you have circled (B) above.

NOTE:

- You will answer more questions like the one completed above.
- Do your best to answer each question even if you are not sure of the answer.
- Write down the answer that you think is the best and move to the next question.
- When you have answered all the questions on a page, move to the next page.
- Look only at your own work.

THE TEST STARTS ON THE NEXT PAGE.

1. MULTIPLE QUESTIONS

1.1 245 499 rounded off to the nearest 1 000 is ...?

- A 245 000
- B 245 490
- C 245 599
- D 245 500

(1)

1.2 Calculate: $74,56 \times 100 = \dots$

- A 7 456
- B 7 456
- C 74,56
- D 745,6

(1)

1.3 Name angle A in the given shape below?

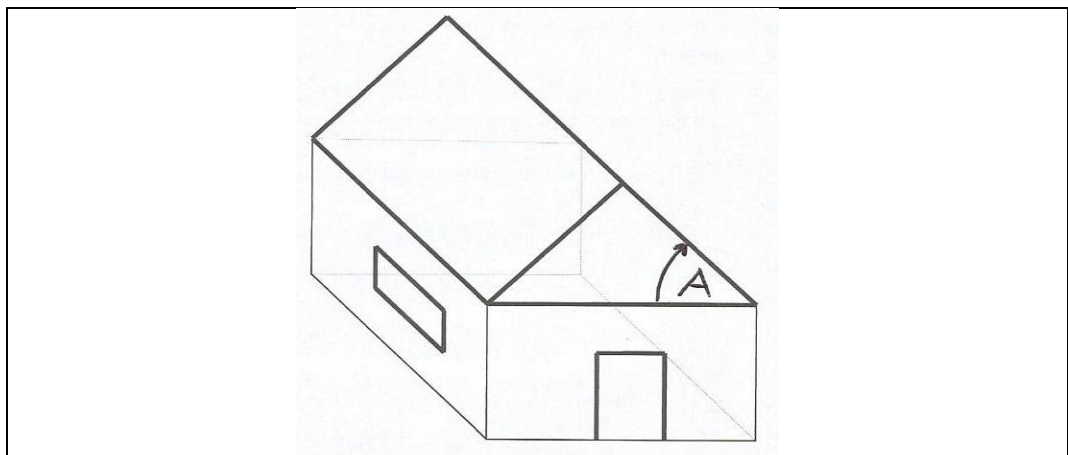

- A Straight angle
- B Obtuse angle
- C Acute angle
- D Right angle

(1)

1.4 The abacus below illustrates ...

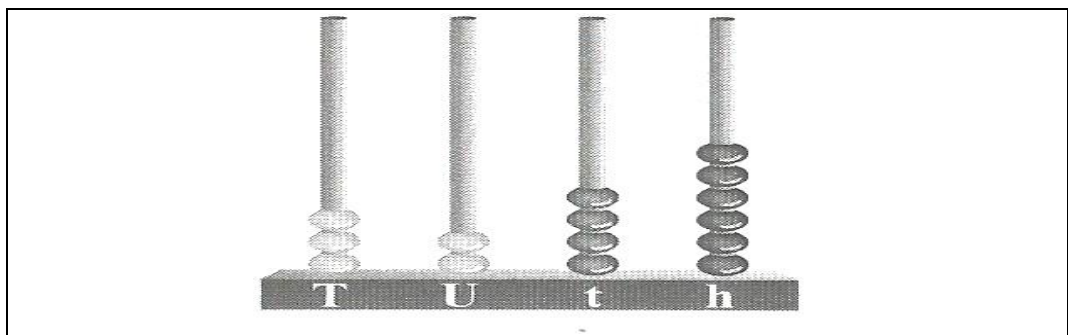

- A 32,64.
- B 23,45.
- C 32,46.
- D 23,46.

(1)

- 1.5 Calculate: $\frac{3}{5}$ of 150
- A 100
B 90
C 120
D 60 (1)
- 1.6 Calculate: 100 minutes are equal to ...
- A 1h10min.
B 1h40min.
C 1h00min.
D 1h30min. (1)
- 1.7 If $384 \div 16 = 2 \times t$, then $t = \dots$
- A 32
B 48
C 16
D 12 (1)
- 1.8 The next number in the **sequence** **3; 9; 27; ...** will be ...
- A 125.
B 36.
C 81.
D 30. (1)
- 1.9 **Four layers** of 1 cm^3 blocks have been used to make the **rectangular prism** below.

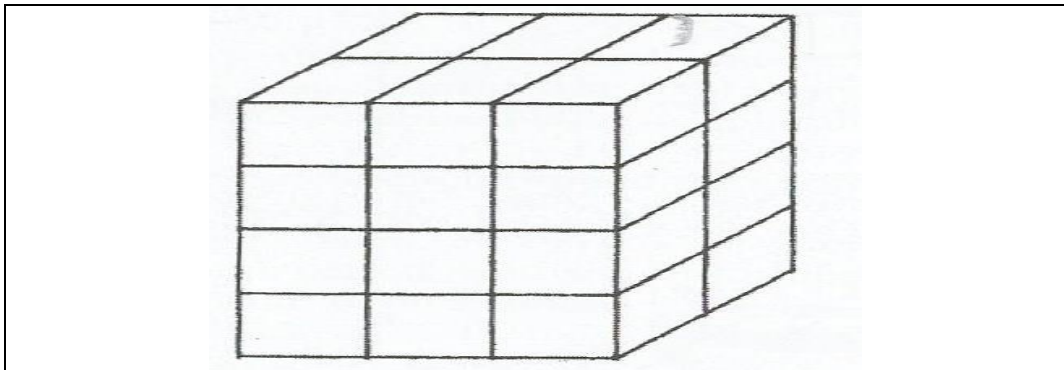

How many 1 cm^3 blocks are there in the whole rectangular prism?

- A 26
B 12
C 24
D 30 (1)

1.10 Which number on a number line is **halfway** between 147 360 and 147 370?

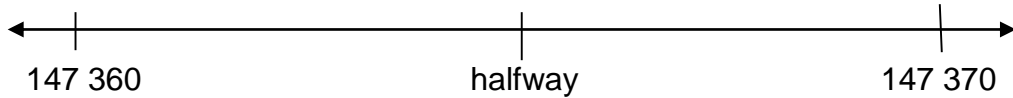

- A 147 375
- B 147 385
- C 147 365
- D 147 355

(1)

2. Fill in the scale reading which is indicated with **arrow P**.

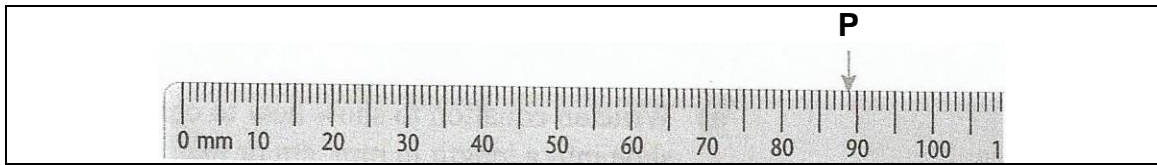

P = _____

(1)

3. Look at the diagram below and answer the following question:

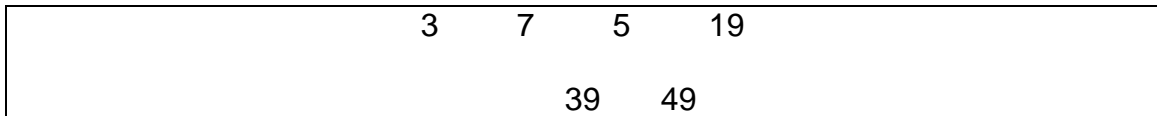

Write down the number that is a **factor** of 9: _____

(1)

4. Farm workers picked 324 587 pears during the morning. After lunch they picked more pears. By the end of the day, they had 866 463 pears.

How many pears did they pick after lunch?

(2)

5. John, Xhanti and Piet participate in an athletics event at school. John ran 10,72 seconds, Xhanti ran 10,7 seconds and Piet ran 10,07 seconds.

Who came first?

(1)

6. Lindiwe spent R 275,95 on ingredients to bake a cake. Yolanda spent R25,50 more than Lindiwe on the ingredients.

How much money did Yolanda spend?

(2)

7. Out of the 40 learners in a Grade 6 class, 5% were absent on Monday.

7.1 What percentage of the learners was present?

(1)

7.2 How many learners were present on Monday?

(2)

8. Anna's baby was born with a mass of 3 500 g. On his first birthday his mass was 9,75 kg.

How much weight did he gain in his first year?

(2)

9. It took Zola 2 min 24sec to do 8 calculations.

How long it take on average to do 1 sum (calculation)?

(2)

10. Lwando is 8 years younger than Luleka. Their combined age is 34 years.

What are their ages?

(4)

11. Look at the following pattern.

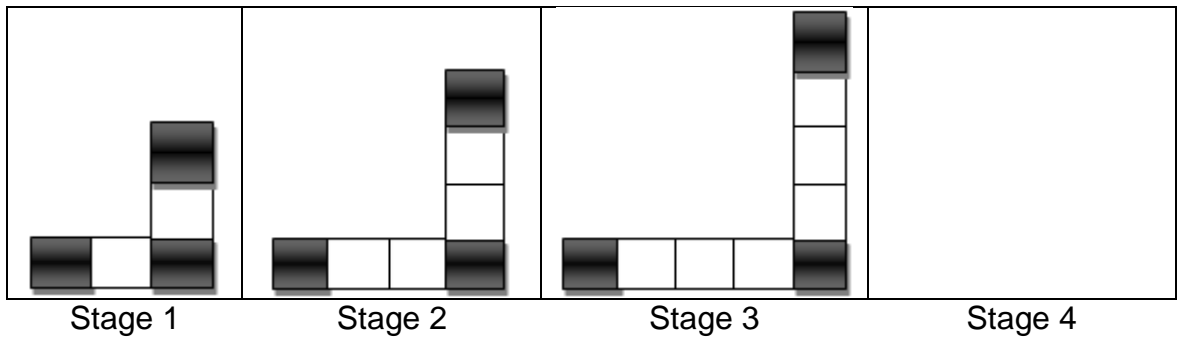

11.1 Draw stage 4 in the space provided.

(1)

11.2 Describe a rule for this pattern. Use your own words.

(1)

11.3 Determine the rule in the following flow diagram.

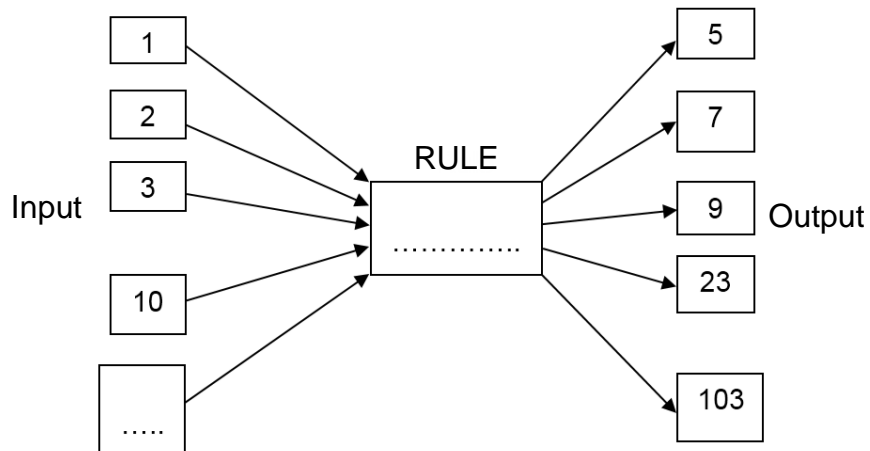

(2)

11.4 Complete the number sentence:

$$2 \times s + 3 = 33 \quad s = \underline{\hspace{2cm}}$$

(1)

12 Calculate:

$$12.1 \quad 19\,634\,567 + 1\,456\,369 + 54\,603 = \dots$$

(2)

$$12.2 \quad 6 - 3,24 = \dots$$

(2)

$$12.3 \quad 5\,436 \times 276 = \dots$$

(3)

$$12.4 \quad 45\,675 \div 145 = \dots$$

(2)

13. Two friends, John and Thabo, earned R400. Thabo worked for longer, so they agreed to share the money in the ratio 3:5.
How much money will each of them get?

(3)

14. Every school, day Siphokazi spends $\frac{1}{3}$ of the day at school and $\frac{1}{4}$ of the day sleeping. She spends $\frac{1}{6}$ of the rest of the day doing homework. The remaining time is divided equally among watching DSTV, practising athletics and eating.

Calculate:

14.1 The total number spent at school and sleeping.

(3)

14.2 The number of hours spent on doing homework.

(1)

15. The diagram below represents a small field.

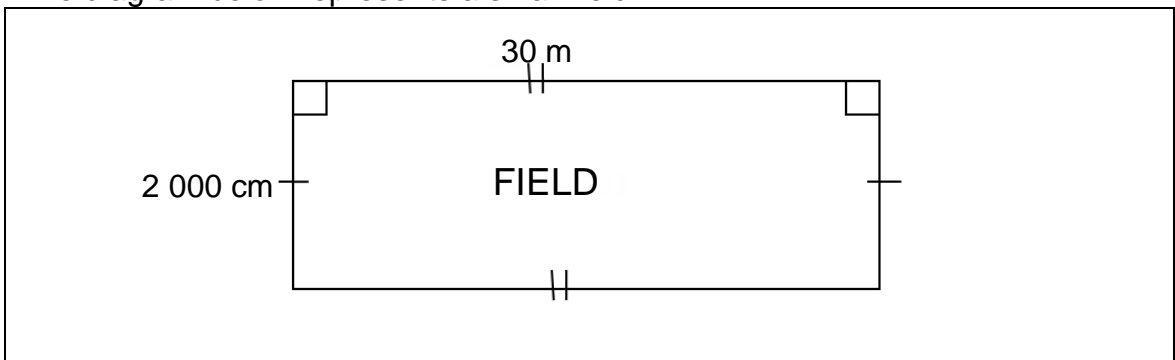

15.1 Find the **perimeter** of the above field and write the answer in metres.

(1)

15.2 Calculate the cost of wire to fence the field at R20 per metre.

(1)

16. Complete the table.

Common fraction	Decimal fraction	Percentage
$\frac{1}{2}$	0,5	50%
_____	0,17	_____
$\frac{1}{8}$	_____	12,5%

(3)

17 Study the shape below and answer the following questions.

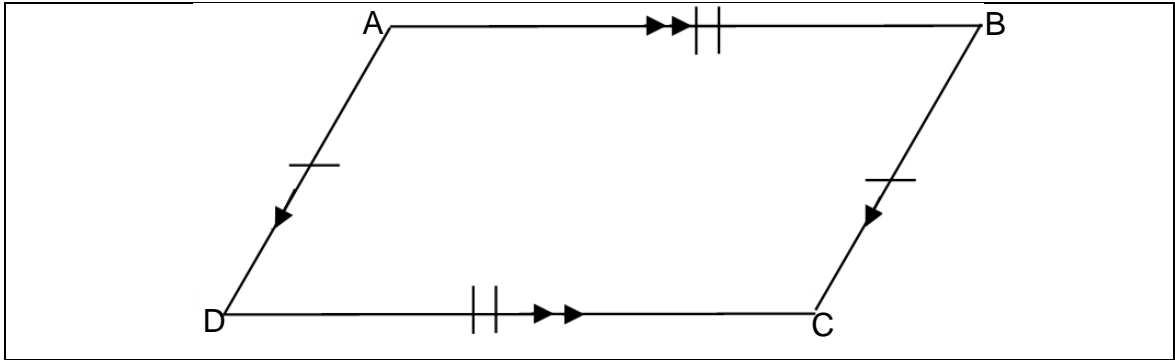

17.1 Name the above 2D shape. _____ (1)

17.2 How many lines of symmetry does the shape have? _____ (1)

17.3 If side \overline{AB} above is 6 cm long, how long will side \overline{CD} be? _____ (1)

18. Complete the following:

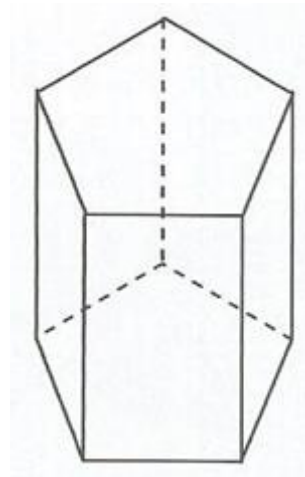

Name of shape _____

Number of faces _____

Number of vertices _____

7

(2)

19. Reduce the length of each side by a factor of 2.

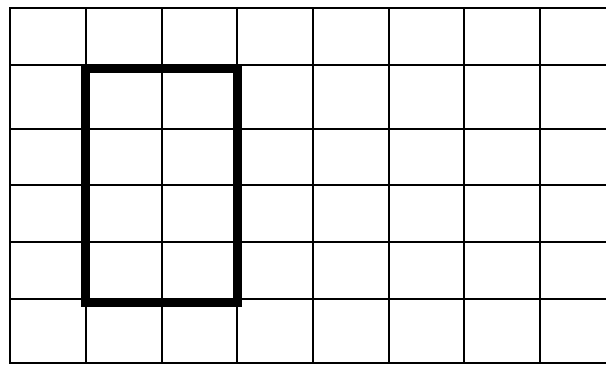



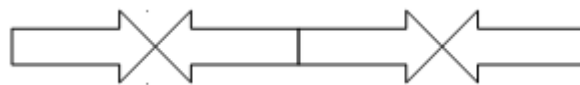

(1)

20. Describe the **transformation** used to create the border pattern shown below.

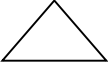

(1)

21. Name the point of position.

	A	B	C	D	E	F
1						
2						
3						
4						
5						
6						

In which block will you find a triangle? _____ (1)

22. Two diagonals bisect a square into triangles.

What is the total number of triangles of different sizes?



(2)

23. **Weather chart A** and **Weather chart B** show the min and max temperatures in some of the larger towns in South Africa at two different times of the year.

Weather chart A			Weather chart B		
Pretoria	11 °C	32 °C	Pretoria	-1 °C	18 °C
Bloemfontein	10 °C	28 °C	Bloemfontein	-3 °C	16 °C
Cape Town	12 °C	29 °C	Cape Town	0 °C	19 °C
Johannesburg	8 °C	30 °C	Johannesburg	-2 °C	20 °C

- 23.1 What does min and max stand for?

(2)

- 23.2 Which **weather chart** shows summer temperatures? Give reasons for your answer.

(2)

24. Sisipho has a bag containing six coloured balls:

1 blue ball; 2 red balls and 3 yellow balls

She puts her hand in the bag and draws a ball.

What is the chance that she will draw a red ball? Write the answer in simplest fraction form.

(1)

25. Complete the following table below by filling the missing spaces.

Grades	Tally marks	Frequency
6a	_____	9
6b	/// I	6
6c	IIII	4
6d	I	1

(1)

26. Learners had the following results for a mathematics test.

84% 69% 50% 70% 75% 72%

Determine the **median** of their results. Median: _____ (1)

27. The pie chart below shows a maize farmer’s annual expenditure on his farm. The circle has been divided into 12 equal parts. Examine the graph and then answer the following questions.

NB. Always write fractions in the simplest form.

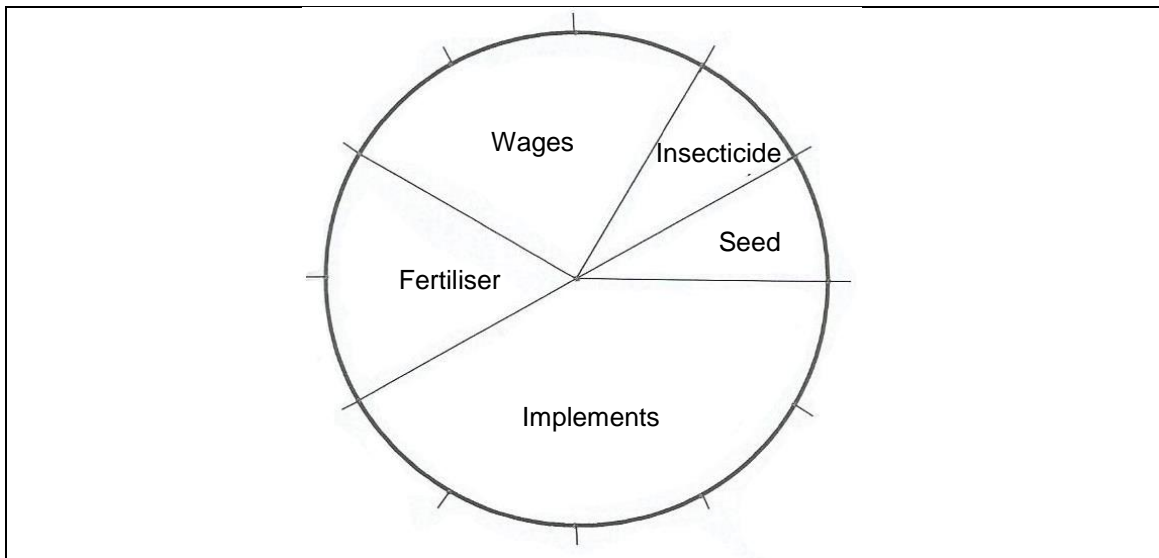

27.1 What percentage of the expenditure was on wages?

_____ (1)

27.2 What fraction of the expenditure was on seed?

_____ (1)

27.3 If the total expenditure was R 480 000, calculate how much he spent on insecticides.

_____ (2)

TOTAL: 75